

COLORING OF GRAPHS WITH NO INDUCED SIX-VERTEX PATH

Thesis submitted in fulfillment of the requirements for the degree

of

Doctor of Philosophy in Computer Science

by

ARNAB CHAR

Under the supervision of

Dr. T. KARTHICK



**COMPUTER SCIENCE UNIT
INDIAN STATISTICAL INSTITUTE
CHENNAI CENTRE**

APRIL 2024

“The Forbidden Forest looked as though it had been enchanted, each tree smattered with silver, and Hagrid’s cabin looked like an iced cake.”

—J. K. Rowling

Dedicated to

Gabriel Pasternak,

for teaching me about accountability.

ACKNOWLEDGMENT

I gratefully acknowledge the constant help and guidance of my supervisor, Dr. T. Karthick. He generously responded to all my questions and allowed me to pursue independent thinking. His deep understanding and thoughtful insight into the subject have always galvanized me to take action. I am much more indebted to him than is reflected in this thesis.

I am grateful to the present and the former Centre Head's of the Indian Statistical Institute, Chennai Centre for providing me with excellent research facilities.

I thank all the members of the Research Fellow Advisory Committee, Computer and Communication Sciences Division for their valuable suggestions and comments.

I would like to express my sincere thanks to all the faculty members of the Computer and Communication Sciences Division of the Indian Statistical Institute: in particular, the faculty members of the Computer Science Unit, ISI Chennai.

During my time at ISI, Chennai, I am grateful to the administration and office staff members for creating a less stressful and research-friendly environment. I would like to thank Kalpana Ma'am, our librarian, for her kind assistance throughout my tenure.

I sincerely acknowledge the ISI administration for providing me with financial support to carry out this research work.

I would like to express my gratitude to all the academic peers I met during my PhD time at ISI, Chennai, specially Dalu chechi, Akshay and Sunil.

To Sanmoyda and Tanusree, you have been one of my supporting pillars that kept me sane during my tough times. Whenever I had academic difficulties during my course work at ISI Kolkata, Spandan has always been there for me. I also want to thank Rachita and Saptarshi.

Finally, I would like to thank my family, specially my parents and my sister for their incredible love, support and keeping me grounded. Without you people's support, it is difficult for me to complete this journey.

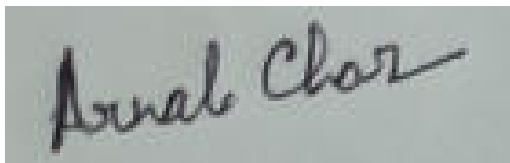

(04/09/2024)

ABSTRACT

Graph coloring is one among the oldest and broadly studied topics in graph theory. A *coloring* of a graph G is an assignment of colors to the vertices of G such that no two adjacent vertices receive the same color, and the *chromatic number* of G (denoted by $\chi(G)$) is the minimum number of colors needed to color G . The *clique number* of G (denoted by $\omega(G)$) is the maximum number of mutually adjacent vertices in G . In this thesis, we focus on some problems on bounding the chromatic number in terms of clique number for certain special classes of graphs with no long induced paths, namely the class of P_t -free graphs, for $t \geq 5$.

A hereditary class of graphs \mathcal{G} is said to be χ -*bounded* if there exists a function $f : \mathbb{N} \rightarrow \mathbb{N}$ with $f(1) = 1$ and $f(x) \geq x$, for all $x \in \mathbb{N}$ (called a χ -*binding function* for \mathcal{G}) such that $\chi(G) \leq f(\omega(G))$, for each $G \in \mathcal{G}$. The smallest χ -binding function f^* for \mathcal{G} is defined as $f^*(x) := \max\{\chi(G) : G \in \mathcal{G} \text{ and } \omega(G) = x\}$. The class \mathcal{G} is called *polynomially χ -bounded* if it admits a polynomial χ -binding function.

An intriguing open question is whether the class of P_t -free graphs is polynomially χ -bounded or not. This problem is open even for $t = 5$ and seems to be difficult. So researchers are interested in finding (smallest) polynomial χ -binding functions for some subclasses of P_t -free graphs. Here, we explore the structure of some classes of P_6 -free graphs and obtain (smallest/linear) χ -binding functions for such classes of graphs. Our results generalize/improve several previously known results available in the literature.

Chapter 1 consists of a brief introduction on χ -bounded graphs and a short survey on known χ -bounded P_6 -free graphs. We also provide motivations, algorithmic issues, and relations of χ -boundedness to other well-known/related conjectures in graph theory.

In Chapter 2, we study the class of $(P_2 + P_3, \overline{P_2 + P_3})$ -free graphs, and show that the function $f : \mathbb{N} \rightarrow \mathbb{N}$ defined by $f(1) = 1, f(2) = 4$, and $f(x) = \max\{x + 3, \lfloor \frac{3x}{2} \rfloor - 1\}$, for $x \geq 3$, is the smallest χ -binding function for the class of $(P_2 + P_3, \overline{P_2 + P_3})$ -free graphs.

In Chapter 3, we are interested in the structure of $(P_5, 4\text{-wheel})$ -free graphs, and in coloring of such graphs. Indeed, we first prove that if G is a connected $(P_5, 4\text{-wheel})$ -free graph, then either G admits a clique cut-set, or G is a perfect graph, or G is a quasi-line graph, or G has three disjoint stable sets whose union meets each maximum clique of G at least twice and the other maximal cliques of G at least once. Using this result, we prove that every $(P_5, 4\text{-wheel})$ -free graph G satisfies $\chi(G) \leq \frac{3}{2}\omega(G)$. We also provide infinitely many $(P_5, 4\text{-wheel})$ -free graphs H with $\chi(H) \geq \frac{10}{7}\omega(H)$.

It is known that every (P_5, K_4) -free graph G satisfies $\chi(G) \leq 5$, and that the bound is tight. Both the class of (P_5, flag) -free graphs and the class of $(P_5, K_5 - e)$ -free graphs generalize the class of (P_5, K_4) -free graphs.

In Chapter 4, we explore the structure and coloring of $(P_5, K_5 - e)$ -free graphs. In particular, we prove that if G is a connected $(P_5, K_5 - e)$ -free graph with $\omega(G) \geq 7$, then either G is the complement of a bipartite graph or G has a clique cut-set. From this result, we show that if G is a $(P_5, K_5 - e)$ -free graph with $\omega(G) \geq 4$, then $\chi(G) \leq \max\{7, \omega(G)\}$. Moreover, the bound is tight when $\omega(G) \notin \{4, 5, 6\}$.

In Chapter 5, we investigate the coloring of (P_5, flag) -free graphs. We prove that every (P_5, flag, K_5) -free graph G that contains a K_4 satisfies $\chi(G) \leq 8$, every (P_5, flag, K_6) -free graph G satisfies $\chi(G) \leq 8$, and that every (P_5, flag, K_7) -free graph G satisfies $\chi(G) \leq 9$. Moreover, we prove that every (P_5, flag) -free graph G with $\omega(G) \geq 4$ satisfies $\chi(G) \leq \max\{8, 2\omega(G) - 3\}$, and that the bound is tight for $\omega(G) \in \{4, 5, 6\}$.

Contents

Contents	III
List of Figures	V
List of Tables	VI
List of Publications	VII
Glossary	VIII
Notation	XII
Some Special Graphs	XIV
1 Introduction	1
1.1 Graph coloring: An overview	1
1.2 Chromatic number and clique number	3
1.3 Beyond perfect graphs: The class of χ -bounded graphs	4
1.4 The class of P_t -free graphs	8
1.5 χ -bounded P_t -free graphs	9
1.6 χ -boundedness and famous conjectures	19
1.7 Outline of the thesis	22
2 Coloring $(P_2 + P_3, \overline{P_2 + P_3})$-free graphs	25
2.1 Introduction	25
2.2 Properties of $(P_2 + P_3, \overline{P_2 + P_3})$ -free graphs that contain a C_4	27
2.3 $(P_2 + P_3, \overline{P_2 + P_3})$ -free graphs that contain a $K_{2,3}$	30
2.4 $(P_2 + P_3, \overline{P_2 + P_3}, K_{2,3})$ -free graphs that contain some special graphs	32
2.5 $(P_2 + P_3, \overline{P_2 + P_3}, K_{2,3})$ -free graphs that contain a C_4	50
2.6 $(P_2 + P_3, \overline{P_2 + P_3})$ -free graphs that contain a C_4	56
2.7 Chromatic bound for $(P_2 + P_3, \overline{P_2 + P_3})$ -free graphs	56
2.8 Conclusion	59

3	Coloring $(P_5, 4\text{-wheel})$-free graphs	60
3.1	Introduction	60
3.2	Some preliminaries	61
3.3	Structural properties of $(P_5, 4\text{-wheel})$ -free atoms that contain a C_5	62
3.4	Structure of $(P_5, 4\text{-wheel})$ -free atoms	68
3.5	Chromatic bound for $(P_5, 4\text{-wheel})$ -free graphs	93
3.6	Concluding remarks	94
4	Coloring $(P_5, K_5 - e)$-free graphs	95
4.1	Introduction	95
4.2	Some preliminaries	97
4.3	Properties of $(P_5, K_5 - e)$ -free graphs that contain a K_3	97
4.4	$(P_5, K_5 - e)$ -free graphs that contain some special graphs	100
4.5	$(P_5, K_5 - e)$ -free graphs that contain a K_4	116
4.6	Chromatic bound for $(P_5, K_5 - e)$ -free graphs	124
4.7	Concluding remarks	126
5	Coloring (P_5, flag)-free graphs	127
5.1	Introduction	127
5.2	Structural properties of (P_5, flag) -free graphs that contain a K_3	128
5.3	(P_5, flag) -free graphs that contain some special graphs	130
5.4	(P_5, flag, K_5) -free graphs that contain a K_4	135
5.5	Chromatic bound for (P_5, flag) -free graphs	138
5.6	Concluding remarks	141
	Bibliography	142

List of Figures

1	Some special graphs on at most four vertices	XIV
2	Some special graphs on five vertices	XIV
3	Petersen graph and the Grötzsch Graph	XIV
4	Clebsh graph, Co-Clebsh graph, and Co-Clebsh graph with one vertex deleted	XV
5	Schläfli graph	XV
6	Co-Schläfli graph	XV
7	Forests on five vertices.	26
8	Labelled graphs I	30
9	Labelled graphs II	32
10	Schematic representation of the graph \mathbb{G}_ℓ	58
11	Sketch of the graph G in Theorem 3.15	70
12	Sketch of the graph G in Lemma 3.18	77
13	Sketch of the graph G in Lemma 3.19 and in Lemma 3.24	79
14	Sketch of the graph G in Theorem 3.25	87
15	Example of a $(P_5, 4\text{-wheel})$ -free graph with $\chi = 10$ and $\omega = 7$	93
16	Labelled graphs III	97
17	Some $(P_5, K_5 - e)$ -free graphs	105
18	The graph H^*	124
19	A $(P_5, K_5 - e)$ -free graph with $\chi = \omega$	125
20	Labelled graphs IV	127
21	Extremal (P_5, flag) -free graphs	140

List of Tables

1	Some extremal graphs	10
2	Extremal $(P_2 + P_3, \overline{P_2 + P_3})$ -free graphs	58
3	Known chromatic bounds for some subclasses of $(P_2 + P_3, \overline{P_2 + P_3})$ -free graphs. . .	59
4	Known chromatic bounds for some subclasses of $(P_5, 4\text{-wheel})$ -free graphs.	94

LIST OF PUBLICATIONS

Published Papers

- ★ A. Char and T. Karthick.
Coloring of $(P_5, 4\text{-wheel})$ -free graphs.
Discrete Mathematics, Volume 345, Issue 5, May 2022. Article no.: 112795.
<https://doi.org/10.1016/j.disc.2022.112795>
- ★ A. Char and T. Karthick.
Improved bounds on the chromatic number of (P_5, flag) -free graphs.
Discrete Mathematics, Volume 346, Issue 9, September 2023. Article no.: 113501.
<https://doi.org/10.1016/j.disc.2023.113501>
- ★ A. Char and T. Karthick.
Optimal chromatic bound for $(P_2 + P_3, \overline{P_2 + P_3})$ -free graphs.
Journal of Graph Theory, Volume 105, Issue 2, February 2024, Pages 149–178.
<https://doi.org/10.1002/jgt.23009>

Submitted Papers

- ★ A. Char and T. Karthick.
On graphs with no induced P_5 or $K_5 - e$.
Journal of Graph Theory, Manuscript No.: JGT-23-352, 14th August, 2023.
Available at <https://arxiv.org/pdf/2308.08166.pdf>
- ★ A. Char and T. Karthick.
 χ -boundedness and related problems on graphs without long induced paths: A survey.
Discrete Applied Mathematics, Manuscript No.: DA16429, 1st February, 2024.

GLOSSARY

We consider only simple, finite and undirected graphs. If G is a graph, then $V(G)$ and $E(G)$ respectively denote its vertex-set and its edge-set. We use standard terminology from Bondy and Murty [11] and West [169]. For easy reference, we give below some of the definitions which are used in this thesis.

Acyclic graph: A graph with no cycles.

Adjacent vertices: Two vertices joined by an edge.

Antihole: The complement graph of a hole.

Atom: A graph which has no clique cut-set.

Big component of a graph: A component with at least two vertices.

Bipartite graph: A graph whose vertex-set can be partitioned into two stable sets.

Chordal graph: A graph that does not contain a hole.

Chromatic number of a graph: The least possible integer k such that the graph admits a k -vertex coloring.

k -chromatic graph: A graph whose chromatic number is equal to k .

Claw: The graph $K_{1,3}$.

Clique covering of a graph: A set of cliques whose union is the vertex-set of the graph.

Clique covering number of the graph G : The chromatic number of the complement graph of G or the smallest possible integer t such that the vertex-set of G can be written as a union of t cliques.

Clique cut-set: A cut-set which is a clique.

Clique of a graph: A set of mutually adjacent vertices.

Clique number of a graph: The largest possible integer t such that the graph contains a clique of size t .

k -coloring or proper k -vertex coloring of a graph: An assignment of k colors to the vertices of a graph such that no two adjacent vertices receive the same color or a partition of the vertex-set of a graph into k stable sets.

Coloring of a graph: A k -coloring of the graph, for some k .

k -colorable graph: A graph with a k -coloring.

Color class with respect to a k -coloring of a graph: A set of vertices with the same color.

Complement graph of the graph G : The graph with vertex-set $V(G)$ and edge-set $\{uv \mid uv \notin E(G)\}$.

Complement graph of a bipartite graph: A graph whose vertex-set can be partitioned into two cliques.

Complete bipartite graph $K_{p,q}$: A graph whose vertex set is a union of two disjoint stable sets of size p and q such that each vertex in one set is adjacent to every vertex in the other.

Complete graph K_t : A simple graph whose vertex-set is a clique of size t .

Component of a graph: A maximal connected subgraph.

Connected graph: A graph in which there is a path between any two vertices.

G contains H : If G has an induced subgraph which is isomorphic to H .

Cut-set or Separator or Separating set: A set of vertices whose removal increases the number of components.

Cut-vertex of a graph: A vertex whose removal increases the number of components.

Cycle/chordless cycle/induced cycle: The graph obtained by joining two pendant vertices of an induced path.

k -cycle: A cycle of length k .

Degree of a vertex v of a graph: The number of vertices adjacent to v .

Disconnected graph: A graph with more than one component.

Distance between a pair of vertices: The length of a shortest path between the vertices.

Even hole: A hole with even number of vertices.

Dominating set of a graph: A subset S of the vertex-set such that every vertex is either in S or has a neighbor in S .

Dominating induced subgraph: The subgraph induced by a dominating set.

Forest: An acyclic graph.

H -free graph G , where H is any graph: If G does not contain H .

(H_1, H_2, \dots, H_k) -free graph G , where H_1, H_2, \dots, H_k ($k \geq 2$) are given graphs: If G does not contain H_i , for any $i \in \{1, 2, \dots, k\}$.

\mathcal{F} -free graph G , where \mathcal{F} is a given class of graphs: If G does not contain any graph in \mathcal{F} .

Girth of the graph G : The smallest possible integer ℓ such that G contains a cycle of length ℓ , if G contains a cycle, else it is ∞ .

Hereditary class of graphs: A graph class \mathcal{C} such that if a graph $G \in \mathcal{C}$ and G' is an induced subgraph of G , then $G' \in \mathcal{C}$.

Hole: An induced cycle of length at least 4.

- Homogeneous set:** A subset S of the vertex-set with at least two vertices such that each vertex not in S is either adjacent to all the vertices in S or non-adjacent to all the vertices in S .
- Imperfect graph:** A graph which is not a perfect graph.
- Independent or stable set of a graph:** A set of mutually non-adjacent vertices.
- Independence or stability number of a graph:** The largest possible integer t such that the graph contains a stable set of size t .
- Induced subgraph on a vertex subset S of G :** The subgraph with vertex-set S and edge-set consisting of edges of G with both the ends in S .
- Isomorphic graphs:** Two graphs G and G' that have an isomorphism between them, that is, there exists a bijection $f : V(G) \rightarrow V(G')$ such that $uv \in E(G)$ if and only if $f(u)f(v) \in E(G')$.
- Join of two vertex disjoint graphs G and H :** The graph with vertex-set $V(G) \cup V(H)$ and edge-set $E(G) \cup E(H) \cup \{uv \mid u \in V(G), v \in V(H)\}$.
- Length of a path/cycle:** The number of edges in a path/cycle.
- Maximal clique of a graph:** A maximal set of mutually adjacent vertices.
- Neighbor of a vertex v :** A vertex which is adjacent to v .
- Non-neighbor of a vertex v :** A vertex which is non-adjacent to v .
- Neighborhood of a vertex v :** The set of neighbors of v .
- Non-adjacent vertices:** If there is no edge joining them.
- Non-neighborhood of a vertex v :** The set of non-neighbors of v .
- Null graph:** A graph whose vertex-set is an empty set.
- Odd antihole:** The complement graph of an odd hole.
- Odd hole:** A hole with odd number of vertices.
- Path/chordless path/induced path:** A graph whose vertices can be ordered such that two vertices are adjacent if and only if they are successive in the ordering.
- (u, v) -path:** A path with u and v as pendant vertices.
- Pendant vertex:** A vertex of degree 1.
- Perfect graph:** A graph such that chromatic number is equal to the clique number for each of its induced subgraph.
- Quasi-line graph:** A graph in which the neighborhood of each vertex can be expressed as a union of two cliques.
- Ramsey number $R(s, t)$:** The minimum possible integer n such that every graph on n vertices contains a clique of size s or a stable set of size t .

Regular graph: A graph in which all the vertices have same degree.

k -regular graph: A regular graph whose common degree is k .

Self-complementary graph: The graph which is isomorphic to its complement graph.

Self-complementary graph class: A graph class \mathcal{C} such that $\mathcal{C} = \overline{\mathcal{C}}$.

Subgraph of a graph G : A graph whose vertices and edges are in G .

Tree: A connected acyclic graph.

Twins in a graph: Two non-adjacent vertices such that the neighborhood of one vertex is contained in the neighborhood of the other.

Union of two vertex disjoint graphs G and H : The graph with vertex-set $V(G) \cup V(H)$ and edge-set $E(G) \cup E(H)$.

Universal vertex of a graph: A vertex which is adjacent to all other vertices.

Wheel: A join of a hole and a K_1 .

k -wheel: A join of a hole of length k and a K_1 .

NOTATION

We use standard notation of Bondy and Murty [11] and West [169]. For easy reference, we list below some of them which we have used in the thesis.

English Symbols

C_ℓ	Induced cycle on ℓ vertices
$d(v)$ or $d_G(v)$	degree of a vertex v in G or $ N_G(v) $ or $ N(v) $
$dist(u, v)$	distance between two vertices u and v
$dist(u, X)$	$\min\{dist(u, x) \mid x \in X\}$
$dist(X_1, X_2)$	$\min\{dist(x_1, x_2) \mid x_1 \in X_1, x_2 \in X_2\}$
$E(G)$	edge-set of G
G	simple, finite and undirected graph
K_ℓ	complete graph on ℓ vertices
m	number of edges in a graph
n	number of vertices in a graph
$N(v)$ or $N_G(v)$	neighborhood of v in G
$\overline{N}(v)$ or $\overline{N}_G(v)$	non-neighborhood of v in G
$N(X)$ or $N_G(X)$, where $X \subseteq V(G)$	$\{v \in V(G) \setminus X \mid N(v) \cap X \neq \emptyset\}$
P_ℓ	Induced path on ℓ vertices
$ X $	cardinality of X
$G - v$	subgraph obtained by deleting a vertex v from G
$G - e$	subgraph obtained by deleting an edge e from G
$G[X]$	subgraph of G induced by the vertex subset X
$G - X$	the graph $G[V(G) \setminus X]$
uv	edge with u and v as end vertices
$V(G)$	vertex-set of G

Greek Symbols

$\alpha(G)$	independence number or stability number of G
$\delta(G)$	minimum degree in G
$\Delta(G)$	maximum degree in G
$\theta(G)$	clique covering number of G
$\chi(G)$	chromatic number of G
$\omega(G)$	clique number of G

Miscellaneous Symbols

\mathcal{G} or \mathcal{C} or \mathcal{H}	class of graphs
$G_1 + G_2$	union of vertex disjoint graphs G_1 and G_2
$G_1 \vee G_2$	join of vertex disjoint graphs G_1 and G_2
\overline{G} or Co- G	complement graph of G
$\overline{\mathcal{G}}$	$\{\overline{G} \mid G \in \mathcal{G}\}$
ℓG	union of ℓ vertex disjoint copies of G
\mathbb{N}	set of natural numbers.
$[k], k \in \mathbb{N}$	$\{1, 2, \dots, k\}$.
$\binom{n}{k}$	$\frac{n!}{k!(n-k)!}$
\cong	isomorphic
$\not\cong$	not isomorphic
\in	belongs to, is an element of
\notin	does not belong to, is not an element of
\cup	union
\cap	intersection
\subseteq	subset, is a subgraph of
$\lfloor x \rfloor$	floor of x (largest integer less than or equal to x)
$\lceil x \rceil$	ceiling of x (smallest integer greater than or equal to x)
\setminus	set difference
\sum	summation
\square or \blacksquare	end or absence of proof

SOME SPECIAL GRAPHS

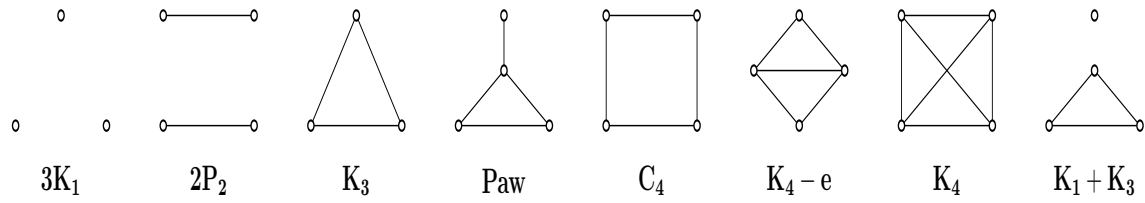

Figure 1: Some special graphs on at most four vertices.

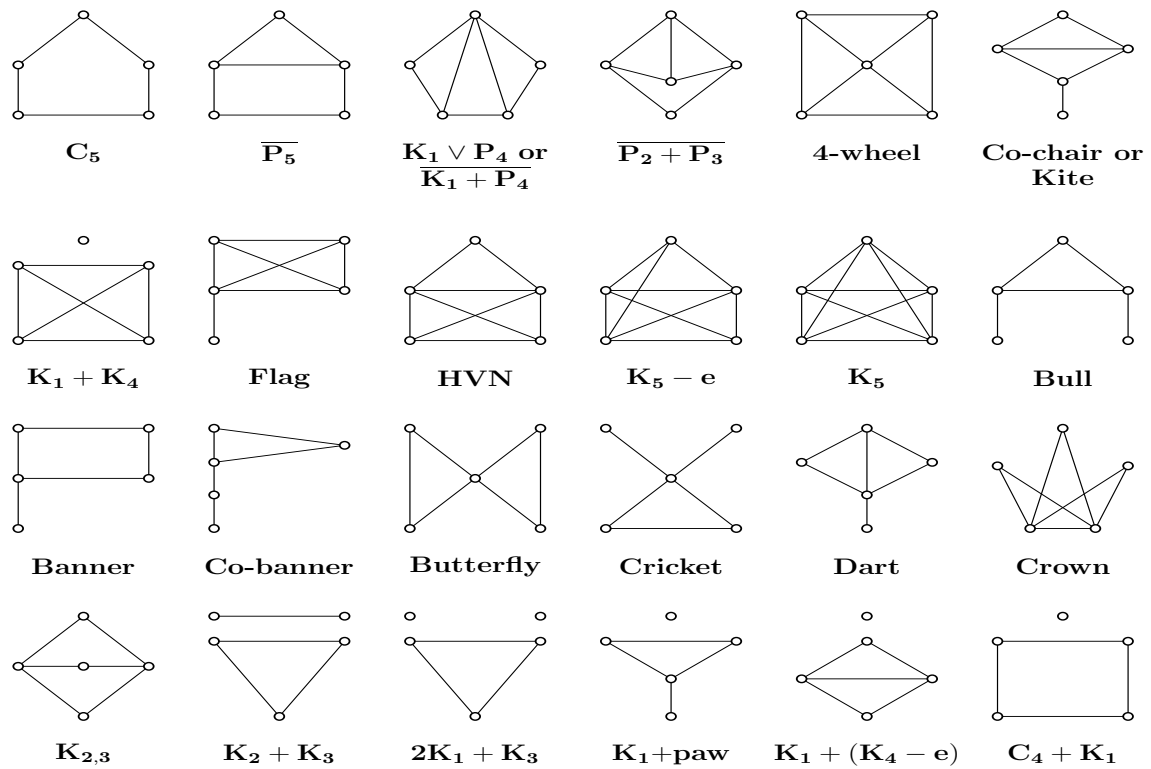

Figure 2: Graphs on five vertices which are not forest.

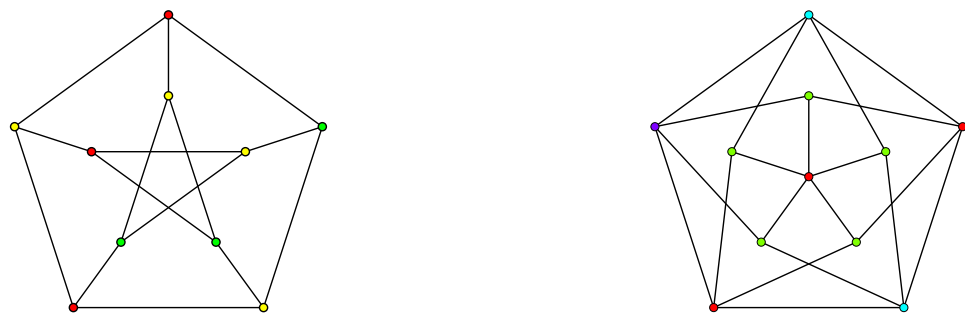

Figure 3: The Petersen graph, and the Grötzsch Graph/the Mycielski's 4-chromatic triangle-free graph (left to right).

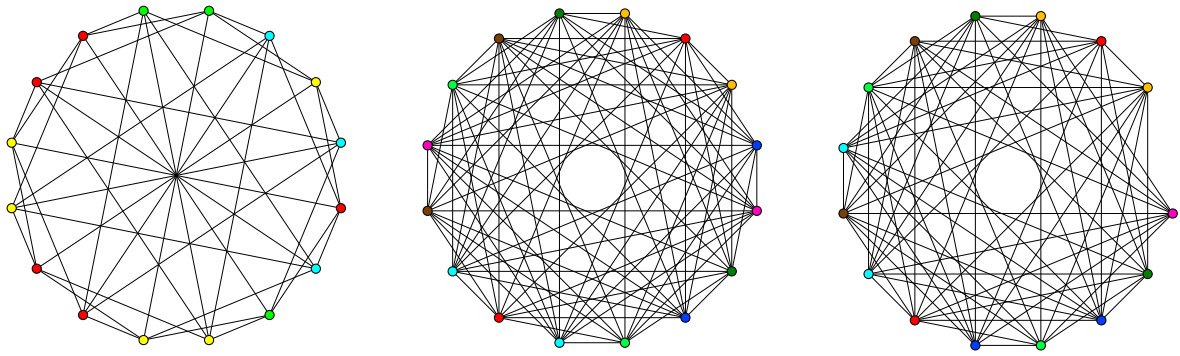

Figure 4: The Clebsch graph, the Co-Clebsch graph, and the Co-Clebsch graph with one vertex deleted (left to right).

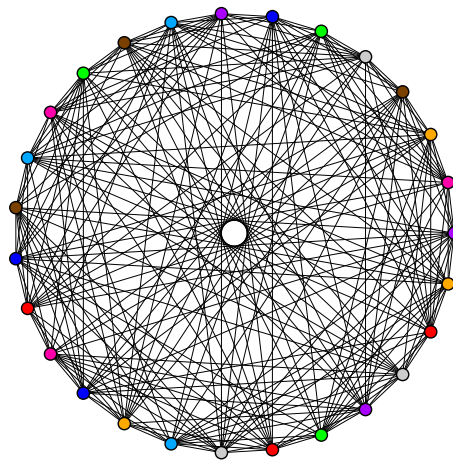

Figure 5: The 16-regular *Schläfli* graph on 27 vertices.

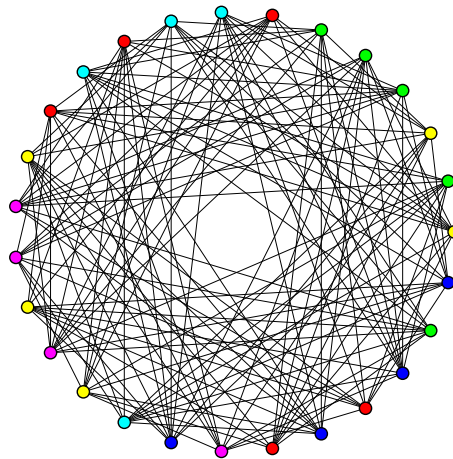

Figure 6: The complement of the 16-regular *Schläfli* graph on 27 vertices.

Chapter 1

Introduction

1.1 Graph coloring: An overview

Graph coloring is one among the oldest and broadly studied topics in graph theory. It started with the ‘Four color problem’ which asks whether the countries of any map can be colored using at most four colors such that no two countries which share a common boundary have the same color. After several partial results, a solution for this problem was given by Appel, Haken and Kosh [1, 2] in 1977 by an extensive use of computer verifications, and is now popularly known as the ‘Four Color Theorem’. In 1997, Robertson, Sanders, Seymour and Thomas [148] gave an improved and significantly simplified proof for the four color theorem using the approach given in [1, 2]. The attempts for a solution of the four color problem give rise to many important notions and novel techniques in graph theory, and motivated the study of various other graph coloring problems/parameters. While vertex coloring and edge coloring are the classical graph colorings, different types of graph colorings have been introduced and explored by many researchers in recent years which include total coloring, list coloring, acyclic coloring, star coloring, equitable coloring, greedy coloring, harmonious coloring etc., A famous book of Jensen and Toft [93] and a monograph edited by Kubale [120] provide an excellent and detailed surveys on various graph colorings. Though graph coloring theory has a remarkable growth since its inception, it is still flooded with numerous challenging unsolved problems. It is evident from a large number of recently published books, monographs, edited book volumes, periodic surveys and theses that graph coloring theory still receives a wide attention all around the world, and is of current interest. In this thesis, we would like to focus on some problems related to classical vertex coloring of graphs¹.

Several real world practical problems such as storage/packing problems, time-tableling/scheduling problems, frequency assignment problems and register allocation problems can be modeled as applications of vertex coloring problems in graphs (see [78, 133] for more). Thus given a general graph, the computation of its chromatic number algorithmically is of interest. This leads to the following decision problems.

¹The contents of this chapter are appearing in “A. Char and T. Karthick. χ -boundedness and related problems on graphs without long induced paths: A survey. Submitted for publication.”

COLORING

Instance: A graph G and a positive integer k .

Question: Is G k -colorable?

 k -COLORING

Instance: A graph G .

Question: Is G k -colorable?

Also, we consider the following optimization version of the vertex coloring problem.

CHROMATIC NUMBER

Instance: A simple graph G .

Question: What is the chromatic number of G ?

These problems play a significant role in the theory of algorithms. By a classical and an early result of Karp [97], for any fixed $k \geq 3$, k -COLORING is known to be NP-complete for an arbitrary class of graphs. Khanna and Linial [107] showed that coloring 3-colorable graphs with 4-colors is NP-hard. It is also known that [128] there exists a fixed constant $\epsilon > 0$ such that approximating the chromatic number of an arbitrary graph within a factor of n^ϵ is NP-hard. Feige and Kilian [65] proved that the chromatic number cannot be approximated within a factor of $O(n^{1-\epsilon})$, for any $\epsilon > 0$, unless $\text{NP} \subseteq \text{ZPP}$, and thus improving an earlier stated result of Lund and Yannakakis [128]. These algorithmic issues motivated the study of k -COLORING for some fixed values of k .

While it is well-known that 2-COLORING can be solved in polynomial time, 3-COLORING remains NP-complete even when the graphs are restricted to planar graphs with degree at most 4 or triangle-free graphs; see [130]. But for the class of perfect graphs, k -COLORING can be solved in polynomial time [80]. These results further motivated the study of k -COLORING for certain special classes of graphs, viz the class of H -free graphs, for some graph H . We refer to an excellent work of Golovach, Johnson, Paulusma and Song [77] for a survey of the current status of the problem, and several other related problems.

Kamiński and Lozin [96] and independently Král, Kratochvíl, Tuza, and Woeginger [119] showed that, for any fixed $k \geq 3$ and $g \geq 3$, k -COLORING is NP-complete for graphs with girth at least g . From this result, it follows that, if H contains a cycle, then k -COLORING is NP-complete for the class of H -free graphs. Also from results of Holyer [88] and Leven and Galil [123], if H is a forest with $\delta(H) \geq 3$, then k -COLORING is NP-complete for the class of H -free graphs. Thus we conclude that k -COLORING is NP-complete for the class of H -free graphs, if H is not isomorphic to the union of disjoint paths. Král, Kratochvíl, Tuza, and Woeginger [119] proved that COLORING can be solved in polynomial time for the class of H -free graphs, whenever H is an induced (not necessarily proper) subgraph of a P_4 or a $P_3 + K_1$; otherwise, the problem is NP-complete.

The computational complexity issues discussed above are the primary motivations of the current research on finding the chromatic number for restricted classes of graphs, finding lower and upper

bounds for the chromatic number in terms of various other parameters of the given graph, and in finding approximation algorithms for the chromatic number. Unfortunately, for a general graph G , the computations of parameters $\omega(G)$ and $\alpha(G)$ are NP-hard. In this thesis, we mainly focus on lower and upper bounds for the chromatic number for some classes of graphs. Some of the important and useful lower and upper bounds for the chromatic number are given below.

- In any coloring of a graph G which uses $\chi(G)$ colors, since each color class has at most $\alpha(G)$ vertices, we have $\chi(G) \geq \frac{|V(G)|}{\alpha(G)}$.
- Given a graph G , in any coloring of G , clearly the vertices of any clique in G require distinct colors. So for any graph G , if H is an induced subgraph of G , then $\chi(H) \geq \omega(H)$. In particular, for any graph G , $\omega(G)$ is an obvious lower bound for $\chi(G)$, and $\chi(G) = 1$ if and only if $\omega(G) = 1$.
- By using a simple ‘greedy algorithm’, the vertices of a given graph G can be colored in polynomial time using at most $\Delta(G) + 1$ colors. Hence every graph G satisfies $\chi(G) \leq \Delta(G) + 1$. Obviously if G is a complete graph or an odd hole, then $\chi(G) = \Delta(G) + 1$. A well-known theorem of Brooks [25] states that if G is not a complete graph or an odd hole, then G satisfies $\chi(G) \leq \Delta(G)$. In other words, he showed that every graph G with $\Delta(G) \geq 3$ and $\omega(G) \leq \Delta(G)$ satisfies $\chi(G) \leq \Delta(G)$.

1.2 Chromatic number and clique number

Bounding the chromatic number of a given graph by its clique number has attracted several researchers. Recall that given a hereditary class of graphs \mathcal{G} , $\chi(G) \geq \omega(G)$, for each $G \in \mathcal{G}$. An important hereditary class of graphs for which the equality holds is one among the well explored classes of graphs in graph coloring theory that has a long history starting from the classical ‘König’s theorem on matchings’, and is given below.

1.2.1 Perfect graphs

Recall that a graph G is said to be *perfect* if $\chi(H) = \omega(H)$, for every induced subgraph H of G , else it is called *imperfect*. Motivated from a question of Shannon [161] on communication channels, Berge [6] initiated the study of the class of perfect graphs. We refer to [140] for more details. Some well-known instances of perfect graphs are: bipartite graphs and their complement graphs, comparability graphs, chordal graphs and the class of P_3 -free graphs. We refer to [89] for many more classes of perfect graphs. Perfect graphs have been broadly studied because of a couple of celebrated conjectures posed by Claude Berge in 1961 [6]

The first conjecture of Berge [6] was settled by Lovász [125] in 1972 (see also [70]). Indeed, Lovász gave different proofs for Theorem 1.1; see [125, 126], and we refer to Gasparian [71] for a simple and elegant proof.

Theorem 1.1 ([125, 126]) (Perfect Graph Theorem) *Given a graph G , the following statements are equivalent: (i) G is perfect. (ii) \overline{G} is perfect. (iii) Every induced subgraph H of G satisfies $\alpha(H) \cdot \omega(H) \geq |V(H)|$.*

The second conjecture of Berge [6] asserted for a characterization of the class of perfect graphs without certain induced subgraphs, is shown to be true by Chudnovsky, Seymour, Robertson and Thomas [42], and is given below.

Theorem 1.2 ([42]) (Strong Perfect Graph Theorem) *A graph G is perfect if and only if G does not contain an odd hole or an odd antihole.*

Chudnovsky et al. [37] gave a polynomial time recognition algorithm for the class of perfect graphs. Moreover, several algorithmic graph theory problems which are well-known to be NP-complete in general can be solved in polynomial time when restricted to the class of perfect graphs; see [78]. In particular, using linear programming techniques, Grötschel, Lovász and Schrijver [80] showed that given a perfect graph G , the parameters $\chi(G)$, $\omega(G)$ and $\alpha(G)$ can be computed in polynomial time. The books of Golombic [78], and Ramirez-Alfonsin and Reed [141] provide an excellent survey of results on perfect graphs and their applications.

1.2.2 The difference $\chi - \omega$ can be arbitrarily large

Given a class of graphs \mathcal{G} , while every graph $G \in \mathcal{G}$ satisfies $\chi(G) \geq \omega(G)$, the following question arises naturally: Is it possible to find an upper bound for $\chi(G)$ in terms of $\omega(G)$, for all $G \in \mathcal{G}$? In other words, for a graph $G \in \mathcal{G}$, how large the difference $\chi(G) - \omega(G)$ can be? The difference $\chi - \omega$ can be arbitrarily large in general. This was shown independently by several authors. Descartes [54] constructed a k -chromatic graph with girth at least 6, for every $k \geq 4$. By means of an excellent recursive construction procedure, Mycielski [135] in 1955 proved the following.

Theorem 1.3 ([135]) *For each $k \in \mathbb{N}$, there exists a triangle-free graph \mathbf{G}_k with $\chi(\mathbf{G}_k) = k$.*

Note that for $k \geq 2$, the graph \mathbf{G}_k in Theorem 1.3 has $3 \times 2^{k-2} - 1$ vertices, which is exponential in k . Erdős [58] proved that for each $k \in \mathbb{N}$, there exists a triangle-free k -chromatic graph with at most k^{50} vertices via a geometric construction. Later in 1959, Erdős [59] proved the following remarkable theorem using non-constructive probabilistic methods.

Theorem 1.4 ([59]) *For all $g \geq 4$ and for sufficiently large k , there exists a k -chromatic graph G with $|V(G)| \leq k^{cg}$ (where $0 < c \leq 2$ is a constant) and girth at least g .*

1.3 Beyond perfect graphs: The class of χ -bounded graphs

From Theorem 1.4, it follows that for a general class of graphs \mathcal{G} , there does not exist a function $f : \mathbb{N} \rightarrow \mathbb{N}$ (where $f(1) = 1$ and $f(x) \geq x$, for all $x \in \mathbb{N}$) such that $\chi(G) \leq f(\omega(G))$, for all $G \in \mathcal{G}$. But, for a restricted class of graphs such a function may exist. For instance, a result of Wagon

[168] states that for $\ell \in \mathbb{N}$, every ℓP_2 -free graph G satisfies $\chi(G) \leq \frac{1}{2^{\ell-1}}(\omega(G) + 1)\omega(G)^{2\ell-3}$. This motivated Gyárfás to introduce the notion of ‘ χ -bounded graphs’ in [81].

Let \mathcal{G} be a hereditary class of graphs. A function $f : \mathbb{N} \rightarrow \mathbb{N}$ such that $f(1) = 1$ and $f(x) \geq x$, for all $x \in \mathbb{N}$ is called a χ -binding function for \mathcal{G} if $\chi(G) \leq f(\omega(G))$, for each $G \in \mathcal{G}$. The class \mathcal{G} is called χ -bounded if there exists a χ -binding function for \mathcal{G} , is *linearly* χ -bounded if f is a linear function, and is *polynomially* χ -bounded if f is a polynomial function. The smallest/optimal χ -binding function f^* for \mathcal{G} is defined as $f^*(x) := \max\{\chi(G) \mid G \in \mathcal{G} \text{ and } \omega(G) = x\}$.

If \mathcal{G} is the class of graphs which is $\{K_t, L_1, L_2, \dots, L_k\}$ -free (where t is fixed), and if $\chi(G) \leq k$, for all $G \in \mathcal{G}$ where $k \geq t - 1$, then we say that the bound is *tight* if there is a graph $H \in \mathcal{G}$ such that $\chi(H) = k$.

Let \mathcal{G} be the class of $\{L_1, L_2, \dots, L_k\}$ -free graphs where $L_i \not\cong K_t$, for each i and fixed t . If every $G \in \mathcal{G}$ satisfies $\chi(G) \leq f(\omega(G))$, we say that the bound is *tight* if there is a graph $H \in \mathcal{G}$ such that $\omega(H) = \ell$ and $\chi(H) = f(\ell)$ for infinitely many values of ℓ .

Note that the class of perfect graphs is a class of χ -bounded graphs with identity function $f(x) = x$ as the smallest χ -binding function. So the notion of χ -boundedness extend the concept of perfection. A graph class \mathcal{G} is said to satisfy the *Vizing bound* if $\chi(G) \leq \omega(G) + 1$, for all $G \in \mathcal{G}$.

The notion of χ -boundedness is well studied in the literature, and it is reflected in several published papers and theses; see for instance [62, 74, 134, 142] and the references therein. Several notions analogous to χ -boundedness were introduced and studied in the literature; see for instance [30, 82, 98]. In this thesis, we restrict our attention to χ -boundedness for some hereditary class of graphs.

The class of χ -bounded graphs has received much attention especially due to several problems and conjectures which were posed by Gyárfás [81], and other related interesting conjectures and problems in graph (coloring) theory. In particular, in the same paper, Gyárfás [81] raised the following.

Meta problem ([81]) For the given hereditary class of graphs \mathcal{G} :

- Does there exist a χ -binding function for \mathcal{G} ?
- Does there exist a polynomial χ -binding function for \mathcal{G} ?
- Does there exist a linear χ -binding function for \mathcal{G} ?
- What is the smallest χ -binding function for \mathcal{G} ?

The answers to the above problems led to the introduction of several new definitions and graph operations which in turn contributed to the evolution of modern graph theory, and initiated the study of several interesting new classes of graphs beyond perfect graphs. A plenty of innovative proof approaches are developed that include deep structure/decomposition theorems which are also useful in other topics of graph theory.

In view of algorithmic graph theory perspective, as pointed out by Gyárfás [81], if a class of graphs \mathcal{G} admits a polynomial χ -binding function, say f , then there is an polynomial approximation

algorithm for CHROMATIC NUMBER with performance ratio at most $\frac{f(\omega(G))}{\omega(G)}$. In particular, if \mathcal{G} admits a linear χ -binding function, then there is a constant factor approximation algorithm for CHROMATIC NUMBER; see [81] for more details.

Recall that not all hereditary class of graphs are χ -bounded, since the class of triangle-free graphs is not χ -bounded, by Theorem 1.3. Also it is long-known that not all polynomially χ -bounded classes of graphs are linearly χ -bounded. For instance, the class of $(P_5, \overline{P_5})$ -free graphs admits a quadratic χ -binding function, and no linear χ -binding function exist for such a class of graphs [68]. Esperet [62] in his thesis asked the following intriguing question:

Is every χ -bounded class of graphs polynomially χ -bounded?

Recently Briański, Davies and Walczak [23] proved that the answer to this question is ‘No’ in general, by showing that there exist hereditary classes of graphs that are χ -bounded but not polynomially χ -bounded. In fact, they proved the following.

Theorem 1.5 ([23]) *For every function $f : \mathbb{N} \rightarrow \mathbb{N} \cup \{\infty\}$ with $f(1) = 1$ and $f(n) \geq \binom{3n+1}{3}$, there exists a hereditary class of graphs \mathcal{G} such that $f(x) = \max\{\chi(G) : G \in \mathcal{G} \text{ and } \omega(G) = x\}$, for every $x \in \mathbb{N}$.*

In the following, we present some strategic tools to obtain a χ -binding function (if exists) for a hereditary class of graphs which are available in the literature.

- **Perfect k -coloring:** We say that a graph G admits a *perfect k -coloring* [26] if its vertex-set can be partitioned into k sets, say V_1, V_2, \dots, V_k , such that each V_i induces a perfect graph. Clearly a graph is perfect if and only if it admits a perfect 1-coloring. Note that a perfect k -coloring of G is also a perfect k -coloring of \overline{G} , by Theorem 1.1. Perfect coloring of graphs provides a measure for graph’s imperfection, and can be used as a tool to obtain a linear χ -binding function (if exists) for a given hereditary class of graphs, and is given below.

Proposition 1.6 ([32]) *Let k be a fixed positive integer. If \mathcal{G} is a hereditary class of graphs such that every $G \in \mathcal{G}$ admits a perfect k -coloring, then \mathcal{G} and $\overline{\mathcal{G}}$ are linearly χ -bounded. In particular, $\chi(G) \leq k \cdot \omega(G)$ and $\chi(\overline{G}) \leq k \cdot \omega(\overline{G})$, for every $G \in \mathcal{G}$.*

- **Perfect divisibility:** A graph G is said to be *perfectly divisible* [85] if for all induced subgraphs H of G , $V(H)$ can be partitioned into two sets X and Y such that $H[X]$ is perfect and $\omega(H[Y]) < \omega(H)$. Clearly perfect graphs are perfectly divisible. The notion of perfect divisibility is useful in finding (quadratic) χ -binding functions (if exist) for some classes of graphs. Indeed, it is not hard to prove the following.

Proposition 1.7 ([49]) *The class of perfectly divisible graphs is χ -bounded with $f(x) = \binom{x+1}{2}$ as the χ -binding function. That is, every perfectly divisible graph G satisfies $\chi(G) \leq \binom{\omega(G)+1}{2}$.*

- **2-divisibility:** A graph G is said to be *2-divisible* [87], if for all (non-empty) induced subgraphs H of G , $V(H)$ can be partitioned into two sets, say X and Y such that $\omega(G[X]) < \omega(H)$ and $\omega(G[Y]) < \omega(H)$. By using induction on the number of vertices, it is easy to show the following.

Proposition 1.8 ([49]) *The class of 2-divisible graphs is χ -bounded with $f(x) = 2^{x-1}$ as the χ -binding function. That is, every 2-divisible graph G satisfies $\chi(G) \leq 2^{\omega(G)-1}$.*

Before we proceed further, we need the following.

Let G be a given graph and let X_1 and X_2 be two disjoint proper subsets of $V(G)$. We say that X_1 is *complete* to X_2 if each vertex of X_1 is adjacent to every vertex of X_2 , and X_1 is *anticomplete* to X_2 if each vertex of X_1 is non-adjacent to every vertex of X_2 . The *distance between X_1 and X_2* is defined as $\min\{\text{dist}(x_1, x_2) \mid x_1 \in X_1, x_2 \in X_2\}$.

We say that two vertex subsets, say S and T of a graph *meets* if $S \cap T \neq \emptyset$, and *meets k times* if $|S \cap T| = k$.

Given a graph H , we say that a graph G contains a *dominating- H* , if there is a subset $S \subseteq V(G)$ which induces H and every vertex in $V(G) \setminus S$ is adjacent to some vertex in S . Also, we say that a graph G contains a *non-dominating- H* , if there is a subset $S \subseteq V(G)$ which induces H , and there is a vertex $v \in V(G) \setminus S$ such that $\{v\}$ is anticomplete to S .

Given a graph G , we say that a graph G is *nice* if it has three pairwise disjoint stable sets, say S_1, S_2 and S_3 , such that $\omega(G - (S_1 \cup S_2 \cup S_3)) \leq \omega(G) - 2$.

Note that a graph G is (H_1, H_2, \dots, H_k) -free if and only if \overline{G} is $(\overline{H_1}, \overline{H_2}, \dots, \overline{H_k})$ -free.

- **Graph expansions/substitutions:** Let G be a given graph on n vertices, say v_1, v_2, \dots, v_n . Let H_1, H_2, \dots, H_n be vertex-disjoint graphs. Then an *expansion* of G , denoted by $G[H_1, H_2, \dots, H_n]$, is the graph constructed from G by replacing each vertex v_i of G by H_i , and for all $i, j \in \{1, 2, \dots, n\}$ and $i \neq j$, if v_i and v_j are adjacent (resp. non-adjacent) in G , then $V(H_i)$ is complete (resp. anticomplete) to $V(H_j)$. An expansion is also referred to as a *substitution* [41]. If $H_i = H$ for each i , then an expansion $G[H, H, \dots, H]$ is the usual *lexicographic product* of G and H , and is denoted $G[H]$. If each H_i is F -free, for a graph F , then an expansion of G is called an *F -free expansion* of G . A $2K_1$ -free expansion of G is called a *clique expansion* of G (and is also called a *blow-up* of G [72, 102]). A clique expansion of a C_5 is called a *complete buoy* in [68]. A K_2 -free expansion of a C_5 is called a *5-ring* in [63]. Note that a K_2 -free expansion of a K_2 is a *complete bipartite* graph, and a K_2 -free expansion of a K_t , $t \geq 3$ is a *complete multipartite* graph. Importantly, Lovász [125] proved that if G and H_1, H_2, \dots, H_n are perfect, then $G[H_1, H_2, \dots, H_n]$ is perfect, and is now known as the Substitution lemma/Replication lemma.

1.4 The class of P_t -free graphs

The class of P_t -free graphs is an extensively studied graph class that also received a wide attention among the researchers for the past few decades. It is a well-known fact that CHROMATIC NUMBER can be solved in polynomial time for the class of P_4 -free graphs [53]. Recall that COLORING is NP-complete for the class of P_t -free graphs when $t \geq 5$. Since the decision problem is NP-complete, CHROMATIC NUMBER for the class of P_t -free graphs is NP-hard, for $t \geq 5$. So one is lead to study k -COLORING for the class of P_t -free graphs. Here we give a brief summary of the known results.

- *k -COLORING for the class of P_5 -free graphs:* Bacsó and Tuza [4] showed that every connected P_5 -free graph has a dominating-complete graph or a dominating- P_3 . Using this result, Hoàng, Kamiński, Lozin, Sawada and Shu [86] showed that k -COLORING for the class of P_5 -free graphs can be solved in polynomial time.
- *3-COLORING for the class of P_t -free graphs, where $t \geq 6$:* Randerath and Schiermeyer [143] showed that given a P_6 -free graph, 3-COLORING can be solved in $O(n^\kappa m)$ -time, where $2 < \kappa < 2.36$. In [12], it is shown that LIST 3-COLORING for the class of P_7 -free graphs can be solved in polynomial time which immediately implies that 3-COLORING for the class of P_7 -free graphs can be solved in polynomial time. Later, the existence of better algorithms with improved time complexity for 3-COLORING for some subclasses of P_7 -free graphs, namely for the class of (P_7, K_3) -free graphs and for the class of $(P_7, \text{odd hole})$ -free graphs were given by Bonomo et al. [13]. However, the problem of determining the computational complexity of 3-COLORING for the class of P_t -free graphs is still open, for $t \geq 8$.
- *k -COLORING for the class of P_t -free graphs, where $t \geq 7$ and $k \geq 4$ or $t = 6$ and $k \geq 5$:* Woeginger and Sgall [170] showed that 4-COLORING for the class of P_{12} -free graphs and 5-COLORING for the class of P_8 -free graphs are NP-complete. Le, Randerath and Schiermeyer [122] extended the result for 4-COLORING and showed that 4-COLORING for the class of P_9 -free graphs is NP-complete. Furthermore, Broersma, Golovach, Paulusma and Song [24] showed that 4-COLORING remains NP-complete for the class of P_8 -free graphs. Finally, Huang [90] extended all the above results and proved that 5-COLORING for the class of P_6 -free graphs and 4-COLORING for the class of P_7 -free graphs are NP-complete, and conjectured that 4-COLORING for the class of P_6 -free graphs can be solved in polynomial time. Recently, Chudnovsky, Spirkl and Zhong [50] showed that Huang's conjecture is true.

In this thesis, we would like to focus on the 'meta questions' of Gyárfás [81] related to χ -boundedness for the class of P_t -free graphs.

1.5 χ -bounded P_t -free graphs

Gyárfás [81] in 1987 showed that the class of P_t -free graphs is χ -bounded with χ -binding function f which satisfies the inequality

$$\frac{R(\lceil t/2 \rceil, x+1) - 1}{\lceil t/2 \rceil - 1} \leq f(x) \leq (t-1)^{x-1}.$$

Randerath and Schiermeyer [144] slightly improved this upper bound for the class of (P_t, K_3) -free graphs, and proved that every (P_t, K_3) -free graph is $(t-2)$ -colorable. In 2003, Gravier, Hoàng and Maffray [79] improved the general upper bound of Gyárfás, and established that for $t \geq 4$ and $\omega(G) \geq 2$, every P_t -free graph G satisfies $\chi(G) \leq (t-2)^{\omega(G)-1}$. A fascinating open question is whether this upper bound can be reduced to a polynomial function in $\omega(G)$. This was posed by Trotignon and Pham [164] (see also [155]):

Problem 1 ([164]) *Is it true that, for every $t \geq 5$, the class of P_t -free graphs is polynomially χ -bounded?*

In 2007, Choudum, Karthick and Shalu [32] suggested a stronger statement in view of Problem 1 for $t = 5$, and is given below.

Conjecture 1 ([32]) *There is constant $c > 0$ such that every P_5 -free graph G satisfies $\chi(G) \leq c \omega(G)^2$.*

Using the notion of ‘online coloring’, Kierstead, Penrice and Trotter [110] claimed (without proof) that they have an improvement to the bound of Gravier et al. to $2^{\omega(G)}$, when $t = 5$. Esperet, Lemoine, Maffray, Morel [63] studied the class of P_5 -free graphs with small cliques, and proved the following.

Theorem A ([63]) *If G is a (P_5, K_3) -free graph, then each component of G is either bipartite or a 5-ring. In particular, $\chi(G) \leq 3$. Moreover, the bound is tight.*

Theorem B ([63]) *Every (P_5, K_4) -free graph G satisfies $\chi(G) \leq 5$, and the bound is tight.*

More generally, they showed that every P_5 -free graph G with $\omega(G) \geq 3$ satisfies $\chi(G) \leq 5 \times 3^{\omega(G)-3}$. So every (P_5, K_5) -free graph G satisfies $\chi(G) \leq 15$, and the problem of finding a tight χ -bound for the class of (P_5, K_5) -free graphs is open. Recently, Scott, Seymour and Spirkl [156] showed that every P_5 -free graph G with $\omega(G) \geq 4$ satisfies $\chi(G) \leq \omega(G)^{\log_2 \omega(G)}$. The problem of reducing this quasi-polynomial upper bound to a polynomial function in $\omega(G)$ seems to be difficult. In other words, Problem 1 is open even for the class of P_5 -free graphs. It is known that the class of P_5 -free graphs does not admit a linear χ -binding function [68]. The existence of a polynomial χ -binding function for the class of P_5 -free graphs implies the Erdős-Hajnal conjecture [61] for the class of P_5 -free graphs; see Section 1.6.4. So the researchers are interested in finding (smallest) polynomial χ -binding functions for some subclasses of P_t -free graphs and for the class of (P_t, H) -free graphs, where $t \geq 5$ and H is a small graph.

Brandt [19] proved that for $\ell \geq 3$, if G is a $(\ell P_2, K_3)$ -free graph, then $\chi(G) \leq 2\ell - 2$. Schiermeyer and Randerath [153] showed that for every $t \geq 5$, the class of $(P_t, K_1 \vee P_4)$ -free graphs is linearly χ -bounded. That is, every $(P_t, K_1 \vee P_4)$ -free graph G satisfies $\chi(G) \leq (t-2)(\omega(G)-1)$. Unfortunately, Problem 1 is open even for a subclass of P_5 -free graphs, namely the class of (P_5, C_5) -free graphs. The best known upper bound for such a class of graphs is exponential in nature which is due to Chudnovsky and Sivaraman [49]. Indeed, they proved that every (P_5, C_5) -free graph G is 2-divisible, and hence $\chi(G) \leq 2^{\omega(G)-1}$, by Proposition 1.8. The problem of finding a polynomially χ -binding function for the class of (P_5, C_5) -free graphs is still open, and this problem seems equally hard as Problem 1 for $t = 5$.

From the above mentioned result of Gravier et al. [79], every P_6 -free graph G with $\omega(G) \geq 3$ satisfies $\chi(G) \leq 4 \times 3^{\omega(G)-1}$. This is the best known upper bound for the class of P_6 -free graphs. However, better bounds are known for some subclasses of P_5 -free graphs, and for some subclasses of P_6 -free graphs which we present in the next two sections below. In particular, we pay more attention on structural/decomposition theorems (if exist) which are used in proving polynomial χ -boundedness for such classes of graphs. The graphs in Table 1 is useful to justify the tightness of the bound for some classes of graphs.

<i>Obs.</i>	<i>Graph G</i>	<i>Property of G</i>	$\omega(G)$	$\chi(G)$	<i>Ref.</i>
1	$C_5[tK_1] + K_l$	$(2P_2, \text{paw}, K_1 \vee P_4)$ -free	$\max\{2, l\}$	$\max\{3, l\}$	
2	$C_5[K_t]$	$(3K_1, C_4, K_1 \vee P_4)$ -free	$2t$	$\lceil \frac{5}{2}t \rceil$	[33, 34]
3	$K_t[C_5]$	$(3K_1, 2P_2, K_1 + K_3, \overline{P_5})$ -free	$2t$	$3t$	[33, 91]
4	$K_t[C_5] \vee K_1$	$(3K_1, 2P_2, K_1 + K_3, \overline{P_5})$ -free	$2t + 1$	$3t + 1$	[33, 91]
5	$C_5[K_1, C_5, K_1, K_1, C_5]$	(P_5, K_4) -free	3	5	[63, 144]
6	Grötzsch Graph	$(P_2 + P_3, 3P_2, K_3)$ -free	2	4	[144]
7	Co-Clebsch graph	$(P_2 + P_3, \overline{P_2} + \overline{P_3}, P_5)$ -free	5	8	[92]
8	Schläfli graph	$(P_2 + P_3, \overline{P_2} + \overline{P_3})$ -free	6	9	[45, 105]
9	Co-Schläfli graph	$(P_2 + P_3, K_4 - e)$ -free	3	6	[105]

Table 1: Some extremal graphs, where $t, p \in \mathbb{N}$.

Proposition 1.9 ([68]) *Let $G_1 \cong C_5$, and for $k \in \mathbb{N}$, let $G_{k+1} \cong C_5[G_k]$. Then for each k , G_k is $(P_5, \overline{P_5}, \text{bull})$ -free with $\omega(G_k) = 2^k$ and $\chi(G_k) \geq (\frac{5}{2})^k$.*

1.5.1 Polynomially χ -bounded P_5 -free graphs

In this section, we present some subclasses of P_5 -free graphs which are polynomially χ -bounded.

Some important basic subclasses of P_5 -free graphs:

- **The class of P_4 -free graphs:** An early result of Seinsche [159] gives a characterization for the class of P_4 -free graphs (also called *cographs* or *complement reducible graphs*). It states that a non-trivial graph G is P_4 -free if and only if for every subset X of vertices either $G[X]$ is disconnected or $\overline{G[X]}$ is disconnected. Corneil, Perl and Stewert [53] showed that any P_4 -free graph can be constructed from a K_1 by means of the union and join operations, and that the class of P_4 -free graphs can be recognized in linear time. Furthermore, the class of P_4 -free graphs is the smallest class of graphs that includes K_1 and is closed under the join and union; see [53]. From above results, one can deduce that every P_4 -free graph is perfect.
- **The class of split graphs:** A split graph is a graph whose vertex-set can be partitioned into a stable set (possibly empty) and a clique (possibly empty). A well-known result of Földes and Hammer [66] gives a characterization for the class of split graphs. Indeed they showed that given a graph G , the following three statements are equivalent: (i) G is a split graph. (ii) G is a $(2P_2, C_4, C_5)$ -free graph. (iii) G and \overline{G} are chordal. It is easy to show that every split graph is a perfect graph.
- **The class of pseudo-split graphs:** A graph is a *pseudo-split* graph if it is $(2P_2, C_4)$ -free. Pseudo-split graphs were introduced by Maffray and Preissmann [129] as a generalization of the class of split graphs. They proved that pseudo-split graphs can be recognized in linear time by using a characterization based on a ‘degree sequence’. Moreover they showed that (see also [9]) a graph is $(2P_2, C_4)$ -free if and only if its vertex-set can be partitioned into three sets V_1, V_2 , and V_3 such that V_1 induces a C_5 or is empty, V_2 is a clique, V_3 is a stable set, V_1 is complete to V_2 , and V_1 is anticomplete to V_3 . Gyárfás [81] (and independently Blászik et al. [9]) proved that the class of $(2P_2, C_4)$ -free graphs is linearly χ -bounded with smallest χ -binding function defined by $f(x) = x + 1$. Indeed, they showed that every such a graph G satisfies $\chi(G) \leq \omega(G) + 1$, and the equality holds if and only if G is not a split graph.
- **The class of $2P_2$ -free graphs:** The class of $2P_2$ -free graphs generalizes the class of split graphs and the class of pseudo-split graphs. Using a construction of Erdős and Hajnal [60], Wagon [168] established that $f(x) = \binom{x+1}{2}$ is a suitable χ -binding function for the class of $2P_2$ -free graphs (see [138] for the class of ℓP_2 -free graphs). As noted by Wagon, this function is not the smallest χ -binding function for such a class of graphs. Indeed, Nagy and Szentmiklóssy (unpublished), and Gaspers and Huang [73] showed that every $(2P_2, K_4)$ -free graph G satisfies $\chi(G) \leq 4$, and the graph $C_5 \vee K_1$ shows that the bound is tight. Thus when G is a $2P_2$ -free graph with $\omega(G) = 3$, Wagon’s bound is not tight. Recently Geißer [74] slightly improved the bound of Wagon by using the same approach of Wagon and proved that every $2P_2$ -free graph G satisfies $\chi(G) \leq \binom{\omega(G)+1}{2} - 2 \left\lfloor \frac{\omega(G)}{3} \right\rfloor$, and that the bound is tight for $\omega(G) \leq 3$. From a result of Chung [51], it is also known that there is a $2P_2$ -free graph G such that $\chi(G) \geq \frac{1}{3}(\omega(G) + 1)^{1+\epsilon}$ for every $\epsilon > 0$. However, the problem of finding the smallest χ -binding function for the class

of $2P_2$ -free graphs is open (see Problem 2.16 in [81]).

Apart from pseudo-split graphs, linear χ -binding functions were proved for subclasses of the class of $2P_2$ -free graphs by many researchers, and we state here a few of them (see [22] and [104] and the references therein for more). Fouquet et al. [68] showed that every $(2P_2, \overline{P_5})$ -free graph G satisfies $\chi(G) \leq \lfloor \frac{3}{2}\omega(G) \rfloor$, and that the bound is tight (see Obs. 3 and Obs. 4 of Table 1 for tight examples). Brause et al. [22] proved that every $(2P_2, K_1 \vee P_4)$ -free graph G satisfies $\chi(G) \leq \max\{3, \omega(G)\}$ which is tight, by Obs. 1 of Table 1. In [104], Karthick and Mishra proved that every $(2P_2, \overline{P_2 + P_3})$ -free graph G satisfies $\chi(G) \leq \omega(G) + 1$ and that the bound is tight. In the same paper, they also showed that every $(2P_2, 4\text{-wheel})$ -free graph G satisfies $\chi(G) \leq \omega(G) + 5$, and that every $(2P_2, \text{HVN})$ -free graph G satisfies $\chi(G) \leq \omega(G) + 3$.

- **The class of $3K_1$ -free graphs:** Note that this class is also a subclass of the class of claw-free graphs which is well-studied in the literature (see [64] for a survey). Chudnovsky and Seymour [46] proved that if G is a connected claw-free graph with $\alpha(G) \geq 3$, then $\chi(G) \leq 2\omega(G)$, and that the bound is ‘asymptotically tight’. We call a graph G with $\alpha(G) \leq 2$ as a $3K_1$ -free graph. From a more general result of Gyarfas [81], it is known that the smallest χ -binding function f^* for the class of $3K_1$ -free graphs satisfies $\frac{1}{2}R(3, x + 1) \leq f^*(x) \leq R(3, x)$. A celebrated result of Kim [113] states that this special Ramsey number $R(3, x)$ has order of magnitude $O(\frac{x^2}{\log x})$. Thus one can conclude that if G is a $3K_1$ -free graph, then $\chi(G)$ is bounded both sides by $O(\frac{\omega(G)^2}{\log \omega(G)})$. It is also known that the class of $(3K_1, 2P_2)$ -free graphs, which is subclass of the class of $3K_1$ -free graphs, does not admit a linear χ -binding function [22]. However, the problem of finding the smallest χ -binding function for the class of $3K_1$ -free graphs is open, and seems to be hopelessly difficult (see [19]). On the other hand, (linear) χ -binding functions were proved for several subclasses of the class of $3K_1$ -free graphs, and we mention here a few of them. Kierstead [111] showed that if G is a $(3K_1, K_5 - e)$ -free graph, then $\chi(G) \leq \omega(G) + 1$. From a result of Hoang and McDiarmid [87], every $(3K_1, C_5)$ -free graph G satisfies $\chi(G) \leq \omega(G)^{3/2}$. Henning et al. [84] proved that if G is a $(3K_1, K_1 + K_4)$ -free graph, then $\chi(G) \leq \frac{3}{2}\omega(G)$, and that the bound is tight (see Obs. 3 and Obs. 4 of Table 1). Later, Joos [94] generalized this result and showed that every $(3K_1, K_1 + K_5)$ -free graph G satisfies $\chi(G) \leq \frac{7}{4}\omega(G)$. Choudum et al. [33] proved a structure theorem and deduced that every $(3K_1, 4\text{-wheel})$ -free graph satisfies $\chi(G) \leq 2\omega(G)$, and they also proved tight chromatic bounds for the class of $(3K_1, F)$ -free graphs, where $F \in \{\text{flag}, \text{kite}, K_1 \vee P_4, \overline{P_5}\}$ using structure theorems.

The class of (P_5, H) -free graphs, where $|V(H)| = 4$ and $\alpha(H) = 2$:

- **The class of (P_5, paw) -free graphs:** From a result of Olariu [136], it is known that if a graph is paw-free, then either it is triangle-free or it is a complete multipartite graph. Since a complete multipartite graph is a perfect graph, and since every $(P_5, \text{triangle})$ -free graph H satisfies $\chi(H) \leq 3$ [63], it follows that every (P_5, paw) -free graph G satisfies $\chi(G) \leq \max\{3, \omega(G)\}$. Clearly this bound is tight, by Obs. 1 of Table 1.

- **The class of (P_5, C_4) -free graphs:** Fouquet et al. [68] examined the class of (P_5, C_4) -free graphs and proved a decomposition theorem for such a class of graphs. Using that result, they deduced that every (P_5, C_4) -free graph G satisfies $\chi(G) \leq \frac{3}{2}\omega(G)$. From a decomposition theorem of Fouquet et al. [68], one can easily deduce that if G is a connected (P_5, C_4) -free graph, then either G has a universal vertex or G has a clique cut-set or G is a clique expansion of a C_5 . It is known that [28] if G is a clique expansion of a C_5 , then $\chi(G) \leq \lceil \frac{5}{4}\omega(G) \rceil$. From these results, it not hard to show that every (P_5, C_4) -free graph G satisfies $\chi(G) \leq \lceil \frac{5}{4}\omega(G) \rceil$, by using induction on the number of vertices (see also [32]). Moreover the bound is tight, by Obs. 2 of Table 1.
- **The class of $(P_5, K_4 - e)$ -free graphs:** Brandstädt [14] studied the structure of $(P_5, K_4 - e)$ -free graphs using the concept of ‘prime graphs’ and ‘modular decomposition’ of graphs, and proved that several algorithmic graph problems can be solved in linear time. Shiermeyer and Randerath [153] showed that every $(P_5, K_4 - e)$ -free graph G satisfies $\chi(G) \leq \omega(G) + 1$. In [30], Choudum and Karthick gave a characterization for the class of $(P_5, K_4 - e)$ -free graphs. Using their characterization, it not difficult to show that if G is a connected $(P_5, K_4 - e)$ -free graph, then either G is perfect or G has a clique cut-set or G has twins or $\chi(G) \leq 3$. Now it is easy to prove that every $(P_5, K_4 - e)$ -free graph G with $\omega(G) \geq 2$ satisfies $\chi(G) \leq \max\{3, \omega(G)\}$, by using induction on the number of vertices (see also [74]). Moreover the bound is tight, by Obs. 1 of Table 1.

The class of (P_5, H) -free graphs, where $|V(H)| = 5$, $\alpha(H) = 2$ and H is $2P_2$ -free:

- **The class of $(P_5, \overline{P_5})$ -free graphs:** In 1993, Fouquet [67] proved a decomposition theorem which states that if G is a $(P_5, \overline{P_5})$ -free graph, then either G has a homogeneous set, or G is isomorphic to C_5 , or G is C_5 -free. (See Chudnovsky et al. [38] for a refinement of this result which gives a characterization for such a class of graphs.) Using this, he proved that this class of graphs can be recognized in $O(n^3)$ time. Later, in 1995, Fouquet et al. [68] showed that every $(P_5, \overline{P_5})$ -free graph G has a vertex-subset T such that $G - T$ is a perfect graph and $\omega(G[T]) \leq \omega(G) - 1$. From this, the authors deduced that every $(P_5, \overline{P_5})$ -free graph G satisfies $\chi(G) \leq \binom{\omega(G)+1}{2}$. They also established that there is no linear χ -binding function for the class of $(P_5, \overline{P_5})$ -free graphs. Indeed they constructed a class of $(P_5, \overline{P_5})$ -free graphs \mathcal{L} such that $\chi(G) \geq \omega(G)^{\log_2 5 - 1}$, for all $G \in \mathcal{L}$ (see Proposition 1.9). These results provide a partial solution for the 35 years old open problem of Gyárfás which asks for the smallest χ -binding function for the class of $(P_5, \overline{P_5})$ -free graphs (see Problem 4.8 in [81]).
- **The class of $(P_5, K_1 \vee P_4)$ -free graphs:** Bodlaender et al. [10] investigated this class of graphs and proved that many well-known NP-complete problems can be solved in linear time. They also showed a linear time algorithm for the recognition of such graphs. On the lines of Bacsó and Tuza [5], Choudum et al. [32] in 2007 proved a decomposition theorem for the class of $(P_5, K_1 \vee P_4)$ -free graphs. It states that if G is a connected $(P_5, K_1 \vee P_4)$ -free graph, then

$V(G)$ can be partitioned into two sets V_1 and V_2 such that $G[V_1]$ contains a dominating- C_5 or $V_1 = \emptyset$, and $G[V_2]$ is a perfect graph. Moreover, $G[V_2]$ is P_4 -free, if $V_1 \neq \emptyset$. As a consequence of this result, they established that every $(P_5, K_1 \vee P_4)$ -free graph G admits a perfect 4-coloring, and hence every such a graph G satisfies $\chi(G) \leq 4\omega(G)$, by Proposition 1.6. In 2019, Randerath and Schiermeyer [153] improved this bound and showed that every $(P_5, K_1 \vee P_4)$ -free graph G satisfies $\chi(G) \leq 3\omega(G) - 3$. Later in 2019, Cameron, Huang and Merkel [28] proved that every $(P_5, K_1 \vee P_4)$ -free graph G satisfies $\chi(G) \leq \frac{3}{2}\omega(G)$ via a structure theorem for such a class of graphs based on prime graphs and modular decomposition which was proven by Brandstädt and Kratsch [16]. Moreover they claimed that the bound is tight. But the bound is not tight except for $\omega(G) = 2$. Recently Chudnovsky et al. [39] proved a structure theorem for the class of $(P_5, K_1 \vee P_4)$ -free graphs which states that if such a graph is connected, then either it is a perfect graph, or it can be obtained from one of the 10 basic graphs (see Fig. 2 of [39]) each contains a C_5 by expanding each vertex of them by a P_4 -free graph, or it belongs to a well-defined specific class of graphs. From this result, they showed that every $(P_5, K_1 \vee P_4)$ -free graph G satisfies $\chi(G) \leq \lceil \frac{5}{4}\omega(G) \rceil$. Moreover the bound is tight, by Obs. 2 of Table 1.

- **The class of $(P_5, \overline{P_2 + P_3})$ -free graphs:** Brandstädt and Hoàng [15] showed that if G is a $(P_5, \overline{P_2 + P_3})$ -free graph which has no clique cut-set, no universal vertex and no twins, then either G is G^* or every C_5 in G is dominating (see [92] for the graph G^*). Huang and Karthick [92] extended this result and established that if G is a $(P_5, \overline{P_2 + P_3})$ -free graph which has no clique cut-set, no universal vertex and no twins, then either G is an induced subgraph of the complement of the Clebsch graph, or G is a P_3 -free expansion of a C_5 , or G has a stable set S such that either $\omega(G - S) \leq \omega(G) - 1$ or $G - S$ is perfect, or it belongs to a special class of graphs. From this result, they deduced that every $(P_5, \overline{P_2 + P_3})$ -free graph G satisfies $\chi(G) \leq \lceil \frac{3}{2}\omega(G) \rceil$, and that the bound is attained by the complement of the 5-regular Clebsch graph on 16 vertices (see Obs. 7 of Table 1). They also proved a complete characterization of a $(P_5, \overline{P_2 + P_3})$ -free graph G that satisfies that satisfies $\chi(G) > \frac{3}{2}\omega(G)$, and constructed a class of $(P_5, \overline{P_2 + P_3})$ -free graphs \mathcal{B} such that every graph $G \in \mathcal{B}$ satisfies $\chi(G) = \lceil \frac{3}{2}\omega(G) \rceil - 1$.
- **The class of (P_5, kite) -free graphs:** Brandstädt and Mosca [18] studied the structure of ‘prime’ (P_5, kite) -free graphs and showed that WEIGHTED INDEPENDENT SET can be solved efficiently. Recently, Brause and Geißer [21] showed that every (P_5, kite) -free graph G satisfies $\chi(G) \leq 3$ (if $\omega(G) \leq 2$) and $\chi(G) \leq 2\omega(G) - 2$ (if $\omega(G) \geq 3$). This implies that every (P_5, kite, K_6) -free graph G satisfies $\chi(G) \leq 8$, and that every (P_5, kite, K_7) -free graph G satisfies $\chi(G) \leq 10$. These bounds do not seem to be tight, and hence the function $f(x) = 2x - 2$ for $x \geq 3$ does not seem to be the smallest χ -binding for the class of (P_5, kite) -free graphs. Indeed, the problem of finding the smallest χ -binding function for the class of $(2P_2, K_1 + K_3)$ -free graphs (which is a subclass of the class of (P_5, kite) -free graphs) is open. Huang, Ju and Karthick [91] proved that every (P_5, kite) -free graph G with $\omega(G) \leq 6$ satisfies $\chi(G) \leq \lfloor \frac{3}{2}\omega(G) \rfloor$, and that the bound is tight. Further, they showed that every (P_5, kite) -free graph G with $\omega(G) \geq 6$

satisfies $\chi(G) \leq 2\omega(G) - 3$, and they proposed the following.

Conjecture 2 ([91]) *Every (P_5, kite) -free graph G satisfies $\chi(G) \leq \lfloor \frac{3}{2}\omega(G) \rfloor$.*

If the conjecture is true, then the bound is tight, by Obs. 3 and Obs. 4 of Table 1.

Since the class of K_4 -free graphs is a subclass of the class of $(\text{HVN}, K_1 + K_4)$ -free graphs, the next two subclasses of P_5 -free graphs generalize the class of (P_5, K_4) -free graphs. So if $H \in \{\text{HVN}, K_1 + K_4\}$ and if G is a (P_5, H) -free graph with $\omega(G) \leq 3$, then $\chi(G) \leq 5$, and the bound is tight [63]. Below we present the status of the smallest χ -binding function for these classes of graphs when $\omega \geq 4$.

The class of (P_5, HVN) -free graphs: In 2016, Malyshev [131] proved that every (P_5, HVN) -free graph G satisfies $\chi(G) \leq \max\{16, \omega(G) + 1\}$. Clearly the bound given by Malyshev is not tight. Geißer [74] showed that given a critical (P_5, HVN) -free graph G , if G is C_5 -free, then either G is perfect or $G \cong \overline{C_7}$, and if G contains a C_5 with $\omega(G) \geq 4$, then $\chi(G) \leq \omega(G) + 1$. Using this result, he proved that every (P_5, HVN) -free graph G with $\omega(G) \geq 4$ satisfies $\chi(G) \leq \omega(G) + 1$. Moreover, the bound is tight.

The class of $(P_5, K_1 + K_4)$ -free graphs: It can be easily shown that if G is a $(P_5, K_1 + K_4)$ -free graph, then $\chi(G) \leq 5\omega(G)$. This can be proved by induction on $\omega(G)$ using the fact that every (P_5, K_4) -free graph is 5-colorable [63] as follows: For any $v \in V(G)$, we have $\chi(G) \leq \chi(G[N(v)]) + \chi(G[\{v\} \cup \overline{N(v)}])$. Now since the set of non-neighbors of any vertex in G induces a (P_5, K_4) -free graph and since $\omega(G[N(v)]) \leq \omega(G) - 1$, we observe that $\chi(G) \leq 5\omega(G[N(v)]) + \chi(G[\{v\} \cup \overline{N(v)}]) \leq 5(\omega(G) - 1) + 5 = 5\omega(G)$. Clearly this bound is not tight. There are examples of such graphs G with $\omega(G) = k$ and $\chi(G) = \lfloor \frac{3}{2}k \rfloor$, for each $k \in \mathbb{N}$ (see Obs. 3 and Obs. 4 of Table 1). The problem of finding the smallest χ -binding function for the class of $(P_5, K_1 + K_4)$ -free graphs is open.

The class of (P_5, H) -free graphs, where $\alpha(H) \geq 3$ or H contains a $2P_2$:

First observe that since the class of $(3K_1, 2P_2)$ -free graphs does not admit a linear χ -binding function [22], for any H_1 and H_2 , if each H_i contains either a $3K_1$ or a $2P_2$, then the class of (H_1, H_2) -free graphs does not admit a linear χ -binding function. So the class of (P_5, H) -free graphs, where $\alpha(H) \geq 3$ or H contains a $2P_2$ does not admit a linear χ -binding function. The problem of finding the smallest χ -binding function for the class of (P_5, H) -free graphs (where $\alpha(H) \geq 3$ or H contains a $2P_2$) is wide open. We give below some known partial results.

- Chudnovsky and Sivaraman [49] proved that every (P_5, bull) -free graph G is perfectly divisible, and so $\chi(G) \leq \binom{\omega(G)+1}{2}$, by Proposition 1.7.
- Karthick, Kaufmann and Sivaraman [99] showed that every (P_6, chair) -free graph is perfectly divisible. This implies that every (P_6, chair) -free graph G satisfies $\chi(G) \leq \binom{\omega(G)+1}{2}$, by Proposition 1.7. Hence for $F \in \{K_1 + P_3, 2K_1 + P_2\}$, every F -free graph is perfectly divisible, and hence every such a graph G satisfies $\chi(G) \leq \binom{\omega(G)+1}{2}$. These results partially settled a problem of Gyárfás; see Problem 2.20 of [81].

- Karthick, Maffray and Pastor [103] proved that if G is a (P_5, banner) -free graph, then either G has a homogeneous set or G is $3K_1$ -free or G is perfect. Geißer [74] proved that every (P_5, banner) -free graph G satisfies $\chi(G) \leq g(\omega(G))$, where $g(x)$ is the smallest χ -binding function for the class of $3K_1$ -free graphs.
- Schiermeyer [152] showed that every $(P_5, \text{butterfly})$ -free graph G satisfies $\chi(G) \leq c \omega(G)^3$ for some fixed $c > 0$. This cubic bound has been improved to a quadratic bound by Dong et al. [56]. They claimed that if G is $(P_5, \text{butterfly})$ -free, then $\chi(G) \leq \frac{3}{2}(\omega(G)^2 - \omega(G))$.
- Schiermeyer [152] established that every connected $(P_5, (K_1 + P_4) \vee K_1)$ -free graph G satisfies $\chi(G) \leq \omega(G)^2$. Since the graph $(P_5, (K_1 + P_4) \vee K_1)$ contains both dart and cricket, $f(x) = x^2$ is also a χ -binding function for the class of (P_5, dart) -free graphs and for the class of $(P_5, \text{cricket})$ -free graphs. Later Brause and Geißer [21] proved that every (P_5, dart) -free graph G satisfies $\chi(G) \leq g(\omega(G))$, where $g(x)$ is the smallest χ -binding function for the class of $3K_1$ -free graphs.
- If G is a $(P_5, \text{Co-banner})$ -free graph, then it is shown that $\chi(G) \leq \binom{\omega(G)+1}{2}$ [22]. However, a better argument for such a class of graphs has been given by Geißer [74]. He proved that every $(P_5, \text{Co-banner})$ -free graph G satisfies $\chi(G) \leq \phi(\omega(G))$, where $\phi(x)$ is the smallest χ -binding function for the $2P_2$ -free graphs.
- Brause et al. [20] showed that if G is a $(P_5, K_{2,3})$ -free graph, then $\chi(G) \leq c \omega(G)^3$, for some fixed $c > 0$. An improvement to this bound was given by Dong, Xu and Xu [55] recently. They proved that for such a graph G , we have $\chi(G) \leq 2\omega(G)^2 - \omega(G) - 3$.
- If G is a $(P_5, K_2 + K_3)$ -free graph, then one can easily show that $\chi(G) \leq \omega(G) + 3\binom{\omega(G)}{2}$, by using the Wagon's technique [168] as follows: Let G be a $(P_5, K_2 + K_3)$ -free graph with $\omega(G) = \omega$. Let K be a maximum clique in G , and say $K := \{v_1, v_2, \dots, v_\omega\}$. For $i, j \in \{1, 2, \dots, \omega\}$, define $K_i := \{v \in V(G) \setminus K \mid K \setminus N(v) = \{v_i\}\}$, and for $i \neq j$, $K_{i,j} := \{v \in V(G) \setminus K \mid \{v_i, v_j\} \not\subseteq K \cap N(v)\}$. Then it is easy to see that each $K_i \cup \{v_i\}$ is a stable set (otherwise, we get a clique of size $\omega + 1$), and that each $G[K_{i,j}]$ is K_3 -free (otherwise, G induces a $K_2 + K_3$). Now since every (P_5, K_3) -free graph is 3-colorable, it follows that $\chi(G) \leq \omega(G) + 3\binom{\omega(G)}{2}$.
- Let $H := K_1 + H^*$, where $H^* \in \{K_1 + K_3, \text{paw}, K_4 - e, C_4\}$ and let $\psi(x)$ be the smallest χ -binding function for the class of (P_5, H^*) -free graphs. Then for any (P_5, H) -free graph G , we have $\chi(G) \leq \omega(G)\psi(\omega(G))$ which can be seen as follows: Let K be a maximum clique in G . Then every vertex in $V(G) \setminus K$ has a non-neighbor in K . Since for any $v \in K$, $G[\{v\} \cup \overline{N(v)}]$ induces a (P_5, H^*) -free graph, we see that $\chi(G) \leq \omega(G)\psi(\omega(G))$. For instance, since every $(P_5, K_4 - e)$ -free graph G' satisfies $\chi(G') \leq \max\{3, \omega(G')\}$, we see that every $(P_5, K_1 + (K_4 - e))$ -free graph G satisfies $\chi(G) \leq \max\{3\omega(G), \omega(G)^2\}$.
- Wu and Xu [171] showed that every (P_5, crown) -free graph G satisfies $\chi(G) \leq \frac{3}{2}(\omega(G)^2 - \omega(G))$.

1.5.2 Polynomially χ -bounded P_6 -free graphs

In this section, we present some subclasses of P_6 -free graphs which are polynomially χ -bounded.

The class of $(P_2 + P_3)$ -free graphs: Two subclasses of P_6 -free graphs are well-explored in the literature with respect to χ -boundedness, one is the class of P_5 -free graphs which we have presented in detail in the last section, and the other is the class of $(P_2 + P_3)$ -free graphs. The class of $P_2 + P_3$ -free graphs includes both the class of $3K_1$ -free graphs and the class of $2P_2$ -free graphs. Bharathi and Choudum [8] showed that $(P_2 + P_3)$ -free graph G satisfies $\chi(G) \leq \binom{\omega(G)+2}{3}$. Clearly this bound is not tight. Several classes of $(P_2 + P_3)$ -free graphs have been shown to admit better (linear/smallest) χ -binding functions, and we list some of them below.

- Let G be a $(P_2 + P_3, K_4 - e)$ -free graph with $\omega(G) \geq 2$. Bharathi and Choudum [8] showed that if $\omega(G) = 2$, then $\chi(G) \leq 4$ (and that the bound is tight, by Obs. 6 of Table 1), and if $\omega(G) \geq 5$, then G is perfect. Karthick and Mishra [105] showed that if $\omega(G) = 3$, then $\chi(G) \leq 6$, and that the bound is tight (see Obs. 9 of Table 1). Prashant et al. [139] showed that if $\omega(G) = 4$, then $\chi(G) = 4$.
- In [31], Choudum and Karthick derived a decomposition theorem for the class of $(P_2 + P_3, C_4)$ -free graphs, and showed that every such graph G satisfies $\chi(G) \leq \lceil \frac{5}{4}\omega(G) \rceil$. Furthermore the bound is tight (see Obs. 2 of Table 1 for the tight examples).
- Wu and Xu [171] proved that if G is a $(P_2 + P_3, \text{crown})$ -free graph, then $\chi(G) \leq \frac{1}{2}\omega(G)^2 + \frac{3}{2}\omega(G) + 1$. Clearly this bound is not tight. However it is known that, since the class of $(P_2 + P_3, \text{crown})$ -free graphs includes the class of $3K_1$ -free graphs which does not admit a linear χ -binding function [22], the class of $(P_2 + P_3, \text{crown})$ -free graphs too does not admit a linear χ -binding function.

The class of $(K_1 + P_4)$ -free graphs: Randerath and Schiermeyer [144] proved that the class of $(K_1 + P_4)$ -free graphs is χ -bounded, and the smallest χ -binding function $f^*(x)$ satisfies $\frac{1}{2}R(3, x+1) \leq f^*(x) \leq \binom{x+1}{2}$. The class of $(K_1 + P_4, \overline{K_1 + P_4})$ -free graphs is a subclass of the class of $(K_1 + P_4)$ -free graphs, which is well-studied by the researchers. Rao [146] studied the structure of $(K_1 + P_4, \overline{K_1 + P_4})$ -free graphs, and Brandstädt, Le and Mosca [17] showed that such graphs has bounded clique-width. With respect to χ -boundedness, if G is a $(K_1 + P_4, \overline{K_1 + P_4})$ -free graph, since the neighborhood (similarly, the non-neighborhood) of any vertex induces a P_4 -free subgraph, and since every P_4 -free graph is perfect, it is easy to prove by induction on $|V(G)|$ that $\chi(G) \leq 2\omega(G) - 1$. In [101], Karthick and Maffray established the best possible bound for the class of $(K_1 + P_4, \overline{K_1 + P_4})$ -free graphs. Indeed they proved a structure theorem for the class of $(K_1 + P_4, \overline{K_1 + P_4})$ -free graphs which states that any $(K_1 + P_4, \overline{K_1 + P_4})$ -free graph is either a perfect graph or it can be obtained from one of the 10 basic graphs (see Fig. 1 of [101]) each contains a C_5 , by expanding each vertex of them by a P_4 -free graph or it belongs to a well-defined class of graphs, namely \mathcal{H} (see [101] for the definition of \mathcal{H}). From this result, they deduced that

every $(K_1 + P_4, \overline{K_1 + P_4})$ -free graph G satisfies $\chi(G) \leq \lceil \frac{5}{4}\omega(G) \rceil$. Moreover the bound is tight (by Obs. 2 of Table 1).

The class of (P_6, H) -free graphs, for various H :

- **The class of $(P_6, \text{triangle})$ -free graphs:** Let G be a (P_6, K_3) -free graph. Randerath, Schiermeyer and Tewes [145] showed that $\chi(G) \leq 4$. Further they showed that if $\chi(G) = 4$ with no twins, then either G contains a Mycielski's 4-chromatic triangle-free graph or G is an induced subgraph of a 16-vertex Clebsch graph. Recently Chudnovsky et al. [47] gave an explicit construction for all (P_6, K_3) -free graphs, and it is based on the 16-vertex Clebsch graph, the 8-vertex Möbius ladder, and the graph obtained from a complete bipartite graph by subdividing each edge of a perfect matching.
- **The class of (P_6, paw) -free graphs:** From an earlier mentioned result of Olariu [136], if G is a (P_6, paw) -free graph, then either it is $(P_6, \text{triangle})$ -free or it is a complete multipartite graph. So from the above item, it follows that every (P_6, paw) -free graph G satisfies $\chi(G) \leq \max\{4, \omega(G)\}$.
- **The class of $(P_6, K_4 - e)$ -free graphs:** Karthick and Maffray [100] established that if G is a $(P_6, E, K_4 - e)$ -free graph, then $\chi(G) \leq \omega(G) + 1$ (here, E is the graph which contains a P_5 plus a pendant vertex attached to the mid-vertex of P_5). Karthick and Mishra [105] proved that the chromatic number of a $(P_6, K_4 - e, K_4)$ -free graph is at most 6, and that the complement of the 16-regular Schläfli graph on 27 vertices attains the bound (see Obs. 8 of Table 1). In the same paper, they showed that every $(P_6, K_4 - e)$ -free graph G satisfies $\chi(G) \leq 2\omega(G) + 5$, and conjectured that every such a graph G satisfies $\chi(G) \leq \omega(G) + 3$. In [27], Cameron, Huang and Merkel confirmed that the conjecture is true in general, and later Goedgebeur, Huang, Ju and Merkel [76] showed that every $(P_6, K_4 - e)$ -free graph G with $\omega(G) \geq 3$ satisfies $\chi(G) \leq \max\{6, \omega(G)\}$, and that the bound is tight.
- **The class of (P_6, C_4) -free graphs:** Brandstädt and Hoàng [15] showed that if a (P_6, C_4) -free graph G has no clique cut-set, then the vertex-set of every C_5 in G is a dominating set, and if G contains a C_6 which is not dominating, then G is the join of a clique expansion of the Petersen graph and a (possibly empty) clique. Gaspers and Huang [72] extended this result on the same lines and showed that if a (P_6, C_4) -free graph G has no clique cut-set, either G contains a vertex with degree at most $\frac{3}{2}\omega(G) - 1$, or G contains a universal vertex, or G is a clique expansion of the Petersen graph or the graph F (see Figure 1 of [72] for the graph F). As a corollary, they proved that every (P_6, C_4) -free graph G satisfies $\chi(G) \leq \frac{3}{2}\omega(G)$. Later, Karthick and Maffray [102] explored the structure of (P_6, C_4) -free graphs further in detail and showed that if G is a (P_6, C_4) -free graph that has no clique cut-set or an universal vertex, then G is either a clique expansion of some special graphs or belongs to several special classes of graphs. As a consequence of this result, they deduced that every (P_5, C_4) -free graph G satisfies $\chi(G) \leq \lceil \frac{5}{4}\omega(G) \rceil$. Moreover, the bound is tight, by Obs. 2 of Table 1.

- **The class of $(P_6, K_1 \vee P_4)$ -free graphs:** Choudum, Karthick and Shalu [32] proved a decomposition theorem which states that if G is a connected $(P_6, K_1 \vee P_4)$ -free graph, then its vertex-set can be partitioned into three sets, say V_1, V_2 and V_3 such that $G[V_1]$ contains a dominating induced giant wheel (if $V_1 \neq \emptyset$), and $G[V_2]$ and $G[V_3]$ are perfect graphs. (Here, a *giant wheel* is either a C_5 or the graph which consists of a kC_5 plus a vertex which is adjacent to exactly three non-consecutive vertices in each C_5 .) Using this result, they showed that every $(P_6, K_1 \vee P_4)$ -free graph admits a perfect 8-coloring which implies that every $(P_6, K_1 \vee P_4)$ -free graph G satisfies $\chi(G) \leq 8\omega(G)$. The current best known upper bound for such a class of graphs follows from a more general result of Schiermeyer and Randerath [153]. That is, every $(P_6, K_1 \vee P_4)$ -free graph G satisfies $\chi(G) \leq 4(\omega(G) - 1)$.

The problem of finding the smallest χ -binding function for the class of (P_6, H) -free graphs, where $|V(H)| \geq 3$ and $H \notin \{K_3, P_4, K_4 - e, C_4, \text{paw}\}$ is open.

1.6 χ -boundedness and famous conjectures

In this section, we present the relation between χ -boundedness and some interesting conjectures in graph coloring theory.

1.6.1 Gyárfás-Sumner Conjecture

Let $\mathcal{L} := \{L_1, L_2, \dots, L_t\}$ be a finite family of graphs. Since there are graphs with arbitrarily large chromatic number and high girth (by Theorem 1.4), if \mathcal{G} is a class of \mathcal{L} -free graphs which is χ -bounded, then one of the graphs in \mathcal{L} must be a forest. Gyárfás [81] and Sumner [163] independently conjectured that the converse is also true:

Conjecture 3 ([81, 163]) *If \mathcal{L} is a finite family of graphs that contains a forest, then the class of \mathcal{L} -free graphs is χ -bounded.*

Observe that it is enough to prove Conjecture 3, when \mathcal{L} is a singleton set, say $\{F\}$, where F is a forest. Kierstead and Penrice [109], and independently Sauer [150] proved that if F is a forest, then the class of F -free graphs is χ -bounded if and only if the class of T -free graphs is χ -bounded for every component T of F . Hence, to prove Conjecture 3, it is enough to prove the following.

Conjecture 4 ([81, 163]) *If T is any tree, then the class of T -free graphs is χ -bounded.*

Besides the class of P_t -free graphs, the class of $K_{1,t}$ -free graphs [81], the class of T -free graphs, when T is a tree of radius two [109] or T is a subdivision of star [154] or T is a particular tree of radius three tree [112], and the class of t -broom-free graphs (where a t -broom is the graph constructed from the $K_{1,t+1}$ by subdividing an edge once) [124] are known to be χ -bounded. Recently due to the pioneering work of Chudnovsky, Scott and Seymour, the conjecture has been verified for some special classes of trees which generalize several previously known results; see [48, 158]. Despite several partial contributions, Conjecture 4 is still open.

1.6.2 Hadwiger Conjecture

If G is a graph, then any graph obtained from a subgraph of G by contracting edges is called a *minor* of G [149]. Kuratowski's theorem [121] says that planar graphs are precisely the graphs that do not contain K_5 or $K_{3,3}$ as a minor. So from the Four color theorem, we conclude that every graph with no K_5 or $K_{3,3}$ minor are 4-colorable. Clearly, if a graph G has no K_2 minor, then G is an empty graph and hence it is 1-colorable; and if a graph G has no K_3 minor, then G is a forest, and hence it is 2-colorable. In 1943, Hadwiger [83] showed that every graph with no K_4 minor is 3-colorable, and posed the following.

Conjecture 5 ([83]) *For any integer $t \geq 0$, every graph with no K_{t+1} minor is t -colorable.*

For $t = 4$, Wagner [167] showed that Conjecture 5 is equivalent to the Four Color Theorem [1, 2], and so Conjecture 5 holds. When $t = 5$, Robertson, Seymour and Thomas [149] showed that Conjecture 5 holds with the aid of the Four color theorem. For $t \geq 6$, Conjecture 5 is open. But for several hereditary classes of graphs Conjecture 5 is shown to be true; see [29]. We refer to Seymour [160], Kawarabayashi [106], and Cameron and Vušković [29] for surveys on Hadwiger's conjecture. In [29], Cameron and Vušković established a relationship between χ -boundedness and Conjecture 5 which is given below.

Theorem 1.10 ([29]) *If \mathcal{G} is a hereditary class of graphs that satisfies the Vizing bound (i.e. every $G \in \mathcal{G}$ satisfies $\chi(G) \leq \omega(G) + 1$), then Conjecture 5 holds for \mathcal{G} .*

By Theorem 1.10, Conjecture 5 hold for the following classes of graphs since they satisfy the Vizing bound for the chromatic number: Perfect graphs, line graphs of simple graphs [166], the class of (chair, HVN)-free graphs [142], the class of (chair, $K_5 - e$)-free graphs [142], the class of (even-hole, $K_4 - e$)-free graphs [117], the class of (P_5 , $K_4 - e$)-free graphs, the class of (P_6 , paw)-free graphs, the class of (P_6 , E , $K_4 - e$)-free graphs [100] and many more; see [29, 153, 165].

1.6.3 Reed Conjecture

In 1998, Reed [147] suggested that the chromatic number of a graph can be upper bounded by a convex combination of its clique number and its maximum degree plus 1, and is given below.

Conjecture 6 ([147]) *For any graph G , we have $\chi(G) \leq \left\lceil \frac{\Delta(G) + \omega(G) + 1}{2} \right\rceil$.*

Odd holes, the Chvatal's 4-regular, 4-chromatic triangle-free graph [52] and $C_5[K_t]$ (see Obs. 2 of Table 1) show that the 'rounding up' in Conjecture 6 is necessary. Conjecture 6 is obvious for graphs G with $\omega(G) \in \{\Delta(G), \Delta(G) + 1\}$, and for graphs G with $\omega(G) = \Delta(G) - 1$, by Brooks' theorem [25]. Using probabilistic methods, Reed [147] verified Conjecture 6 for graphs G which have sufficiently large $\Delta(G)$ and $\omega(G)$ is sufficiently close to $\Delta(G)$. He also showed that there is some $k > 0$ such that every graph G satisfies $\chi(G) \leq \lceil k\omega(G) + (1 - k)(\Delta(G) + 1) \rceil$. Furthermore, Conjecture 6 has been verified for some special classes of graphs such as: Line graphs of multigraphs

[116], the class of almost-split graphs [118], the class of $K_{1,3}$ -free graphs [114], the class of (odd hole)-free graphs [3], some subclasses of chair-free graphs [3], graphs with disconnected complements [140], and for graphs with restrictions on Δ and χ ; see [118, 140]. However, Conjecture 6 is still open in general, and seems a lot harder even for the class of triangle-free graphs. Kostochka (cf. [93]) showed that if G is a triangle-free graph, then $\chi(G) \leq \frac{2}{3}(\Delta(G) + 2)$.

In 2008, Gernet and Rabern [75] was the first to explore the relation between χ -boundedness and Conjecture 6. Indeed, they proved the following.

Theorem 1.11 ([75]) *If \mathcal{G} is a hereditary class of graphs such that every $G \in \mathcal{G}$ satisfies $\chi(G) \leq \omega(G) + 2$, then Conjecture 6 holds for \mathcal{G} .*

This implies that the class of graphs which satisfies the Vizing bound satisfies Conjecture 6. We refer to the last paragraph of Section 1.6.2 for several such classes of graphs. In 2018, Karthick and Maffray [101], by using a result of King [115] which states that every graph H with $\omega(H) > \frac{2}{3}(\Delta(H) + 1)$ has a stable set which meets every maximum clique of H , showed the following:

Theorem 1.12 ([101]) *If \mathcal{G} is a hereditary class of graphs such that every $G \in \mathcal{G}$ satisfies $\chi(G) \leq \lceil \frac{5}{4}\omega(G) \rceil$, then Conjecture 6 holds for \mathcal{G} .*

Since the class of (P_6, C_4) -free graphs and the class of $(K_1 + P_4, \overline{K_1 + P_4})$ -free graphs have $f(x) = \lceil \frac{5}{4}x \rceil$ as the χ -binding function, it follows that Conjecture 6 holds for such classes of graphs, by Theorem 1.12. The converse of Theorem 1.12 is not true in general. For instance, the class of $(P_5, \overline{P_5})$ -free graphs satisfies Conjecture 6 [69], but it is known that no linear χ -binding function exists for such a class of graphs [68].

Conjecture 6 is open for the class of P_5 -free graphs. Schiermeyer [151] showed that if G is a connected P_5 -free graph with $\omega(G) \geq 3$ and with at least $10\omega(G) \times 3^{\omega(G)-3}$ vertices, then Conjecture 6 holds for G . From earlier sections, for $L_1 \in \{K_4 - e, \text{paw}, \text{HVN}\}$, since every (P_5, L_1) -free graph G satisfies $\chi(G) \leq \omega(G) + 2$, it follows that Conjecture 6 holds for the class of (P_5, L_1) -free graphs, by Theorem 1.11. Also for $L_2 \in \{C_4, K_1 \vee P_4\}$, since every (P_5, L_2) -free graph G satisfies $\chi(G) \leq \lceil \frac{5}{4}\omega(G) \rceil$, Conjecture 6 holds for the class of (P_5, L_2) -free graphs, by Theorem 1.12. Recently Geißer [74] verified Conjecture 6 for the class of (P_5, banner) -free graphs and for the class of (P_5, dart) -free graphs. We refer to [69, 151] for more partial contributions to Conjecture 6 for the class of P_5 -free graphs.

1.6.4 Erdős-Hajnal Conjecture

From a result of Erdős [57] on Ramsey theory, it is known that every graph on n vertices contains a clique or stable set of size at least $\frac{1}{2} \log n$. If G is perfect graph, since $\alpha(G)\omega(G) \geq |V(G)|$, we see that G has either a clique or a stable set of size at least $\sqrt{|V(G)|}$. Erdős and Hajnal [61] showed that given a graph H , there exists a constant $c > 0$ such that every H -free graph G has either a

clique or a stable set of size at least $e^c \sqrt{\log |V(G)|}$. We say that a hereditary class of graphs \mathcal{G} satisfies the *Erdős-Hajnal property* if there exists a constant $c > 0$ such that every graph $G \in \mathcal{G}$ has either a clique or a stable set of size at least $|V(G)|^c$. (In other words, $\max\{\omega(G), \alpha(G)\} \geq |V(G)|^c$.) In 1989, Erdős and Hajnal [61] suggested the following.

Conjecture 7 ([61]) *For any graph H , the class of H -free graphs has the Erdős-Hajnal property.*

Some partial contributions are available in the literature, and we mention here a few of them. Note that the conjecture is trivially true for H is P_2 or $2K_1$, and that the class of H -free graphs has the Erdős-Hajnal property if and only if the class of \overline{H} -free graphs has the Erdős-Hajnal property. By a result of Kim [113], since the Ramsey number $R(3, t)$ has order of magnitude $O(\frac{t^2}{\log t})$, every triangle-free graph on n vertices has independence number at least $O(\sqrt{n \log n})$, and so the class of triangle-free graphs has the Erdős-Hajnal property. If $H \in \{K_1 + P_2, P_3, P_4\}$, then since every H -free graph is perfect, the class of H -free graphs has the Erdős-Hajnal property. In fact, all graphs on at most four vertices are known to satisfy Conjecture 7; see [44]. Chudnovsky and Safra [43] showed that Conjecture 7 holds when H is a bull. More precisely, they showed that every bull-free graph G has a clique or a stable set of size at least $|V(G)|^{\frac{1}{4}}$. Reed asked whether the class of (P_5, C_5) -free graphs has the Erdős-Hajnal property (see Problem 38 of [162]). Very recently, Chudnovsky, Scott, Seymour and Spirkl [44] showed that Conjecture 7 is true for the class of C_5 -free graphs, and hence the class of (P_5, C_5) -free graphs has the Erdős-Hajnal property. However the conjecture is open when H is P_5 or $\overline{P_5}$. We refer to a survey of Chudnovsky [35] for more details and related results.

In [155], Scott and Seymour established the connection between χ -boundedness and the Erdős-Hajnal conjecture.

Theorem 1.13 ([155]) *If \mathcal{G} is a hereditary class of graphs that admits a polynomial χ -binding function, then \mathcal{G} has the Erdős-Hajnal property.*

Indeed, if every graph $G \in \mathcal{G}$ is such that $\chi(G) \leq \omega(G)^k$, for some integer $k \geq 1$, then since $|V(G)| \leq \chi(G)\alpha(G) \leq \omega(G)^k \alpha(G)$, G has a clique or a stable set of size $|V(G)|^{\frac{1}{k+1}}$. Clearly the converse of Theorem 1.13 is not true in general. For instance, the class of triangle-free graphs has the Erdős-Hajnal property, but is not χ -bounded.

1.7 Outline of the thesis

In this thesis, we study the (smallest) χ -binding function for the class of $(P_2 + P_3, \overline{P_2 + P_3})$ -free graphs, the class of $(P_5, 4\text{-wheel})$ -free graphs, the class of $(P_5, K_5 - e)$ -free graphs, and for the class of (P_5, flag) -free graphs. Our results generalize/improve several previously known results in the literature which were stated in the earlier sections. We give below a chapter-wise summary for each of the remaining chapters.

Chapter 2: Coloring $(P_2 + P_3, \overline{P_2 + P_3})$ -free graphs

For a fixed forest F , the problem of finding the smallest χ -binding function for the class of (F, \overline{F}) -free graphs is open [81] and seems to be hard even when F is a simple type of forest such as a long path or a subdivided claw. So it is interesting to look for some special cases, in particular, when F is a forest on at most five vertices. In this chapter, we are interested in finding the smallest χ -binding function for the class of $(P_2 + P_3, \overline{P_2 + P_3})$ -free graphs.

From a result of Randerath, Schiermeyer and Tewes [145], it is known that every $(P_2 + P_3, \overline{P_2 + P_3})$ -free graph G with $\omega(G) = 2$ satisfies $\chi(G) \leq 4$, and that the bound is tight (see Obs.6 of Table 1). However, no smallest χ -binding function is known for the class of $(P_2 + P_3, \overline{P_2 + P_3})$ -free graphs in general. In this chapter, we show that the function $g : \mathbb{N} \rightarrow \mathbb{N}$ defined by $g(1) = 1, g(2) = 4$, and $g(x) = \max \left\{ x + 3, \left\lfloor \frac{3x}{2} \right\rfloor - 1 \right\}$, for $x \geq 3$, is the smallest χ -binding (or θ -binding) function for the class of $(P_2 + P_3, \overline{P_2 + P_3})$ -free graphs. Our result improves/generalizes the earlier mentioned results known for the class of $(2P_2, C_4)$ -free graphs, the class of $(P_2 + P_3, C_4)$ -free graphs, the class of $(P_2 + P_3, \text{paw})$ -free graphs, and the class of $(P_2 + P_3, K_4 - e)$ -free graphs.

Chapter 3: Coloring $(P_5, 4\text{-wheel})$ -free graphs

The class of $(P_5, 4\text{-wheel})$ -free graphs generalizes the class of: $(2P_2, 4\text{-wheel})$ -free graphs, $(3K_1, 4\text{-wheel})$ -free graphs, (P_5, C_4) -free graphs, and $(P_5, K_4 - e)$ -free graphs. Recall that every (P_5, C_4) -free graph H satisfies $\chi(H) \leq \lceil \frac{5}{4}\omega(H) \rceil$. In [32], Choudum et al. proved a decomposition theorem which states that if G is a connected $(P_5, 4\text{-wheel})$ -free graph, then $V(G)$ can be partitioned into two sets V_1 and V_2 such that $G[V_1]$ contains a dominating C_4 or $V_1 = \emptyset$, and $G[V_2]$ is (P_5, C_4) -free. Using these two results, Choudum et al. [32] deduced that every $(P_5, 4\text{-wheel})$ -free graph G satisfies $\chi(G) \leq 5 \lceil \frac{5}{4}\omega(G) \rceil$. Obviously this bound is not tight.

In this chapter, we explore the structure of $(P_5, 4\text{-wheel})$ -free graphs in detail and prove that if G is a connected $(P_5, 4\text{-wheel})$ -free graph which has no clique cut-set, then either G is a perfect graph, or G is a quasi-line graph, or G has three disjoint stable sets S_1, S_2 and S_3 whose union meets each maximum clique of G at least twice and the other maximal cliques of G at least once. It is known that every quasi-line graph H satisfies $\chi(H) \leq \frac{3}{2}\omega(H)$ [40]. As a consequence of these results, we prove that every $(P_5, 4\text{-wheel})$ -free graph G satisfies $\chi(G) \leq \frac{3}{2}\omega(G)$. We also provide infinitely many $(P_5, 4\text{-wheel})$ -free graphs H with $\chi(H) \geq \frac{10}{7}\omega(H)$.

Chapter 4: Coloring $(P_5, K_5 - e)$ -free graphs

In this chapter, we investigate the class of $(P_5, K_5 - e)$ -free graphs which generalizes the class of (P_5, K_4) -free graphs and the class of $(P_5, K_4 - e)$ -free graphs. Malyshev and Lobanova [132] explored this class of graphs and proved that if G is a connected $(P_5, K_5 - e)$ -free graph with no clique cut-set, then either $\omega(G) \leq 3 \times 6^7$ or G is $3K_1$ -free. Kierstead [108] (see also [111]) showed that every $(3K_1, K_5 - e)$ -free graph H satisfies $\chi(H) \leq \omega(H) + 1$. From these results, it follows that if G is a connected $(P_5, K_5 - e)$ -free graph with $\omega(G) > 3 \times 6^7$ and has no clique cut-set, then

$\chi(G) \leq \omega(G) + 1$. In 2024, Xu [173] claimed that if G is a connected $(P_5, K_5 - e)$ -free graph that contains a C_5 and has no clique cut-set, then G satisfies $\chi(G) \leq \max\{13, \omega(G) + 1\}$.

Here, we study the structure of a $(P_5, K_5 - e)$ -free graph G with $\omega(G) \geq 5$ in detail and prove that either G is the complement of a bipartite graph or G has a clique cut-set or $\chi(G) \leq 7$. Based on this structural result, we show that if G is a connected $(P_5, K_5 - e)$ -free graph with $\omega(G) \geq 7$, then either G is the complement of a bipartite graph or G has a clique cut-set. Furthermore, there is a connected $(P_5, K_5 - e)$ -free imperfect graph H with $\omega(H) = 6$ and has no clique cut-set. Using these results, we prove that if G is a $(P_5, K_5 - e)$ -free graph with $\omega(G) \geq 4$, then $\chi(G) \leq \max\{7, \omega(G)\}$, and that the bound is tight when $\omega(G) \notin \{4, 5, 6\}$.

Since k -COLORING for the class of P_5 -free graphs can be solved in polynomial time for every fixed positive integer $k \leq 6$ [86], it follows from our result and an observation of Ju and Huang [95] that CHROMATIC NUMBER for the class of $(P_5, K_5 - e)$ -free graphs can be solved in polynomial time.

Chapter 5: Coloring (P_5, flag) -free graphs

In this chapter, we are interested in the class of (P_5, flag) -free graphs which generalizes the class of (P_5, K_4) -free graphs and the class of (P_5, paw) -free graphs. Recall that every (P_5, K_4) -free graph G satisfies $\chi(G) \leq 5$ and that the bound is tight. Recently Dong et al. in [55] showed that every (P_5, flag) -free graph G satisfies $\chi(G) \leq 3\omega(G) + 11$, and later in [56], the same authors improved their bound, and proved that every (P_5, flag) -free graph G satisfies $\chi(G) \leq \max\{15, 2\omega(G)\}$. This implies that if G is a (P_5, flag, K_5) -free graph, then $\chi(G) \leq 15$. However, even the improved function $f(x) = \max\{15, 2x\}$ does not seem to be the smallest χ -binding function for such a class of graphs.

Here, we prove that every (P_5, flag, K_5) -free graph G that contains a K_4 satisfies $\chi(G) \leq 8$, every (P_5, flag, K_6) -free graph G satisfies $\chi(G) \leq 8$, and that every (P_5, flag, K_7) -free graph G satisfies $\chi(G) \leq 9$. We also gave examples to show that the given bounds are tight. Moreover we prove that every (P_5, flag) -free graph G with $\omega(G) \geq 4$ satisfies $\chi(G) \leq \max\{8, 2\omega(G) - 3\}$, and that the bound is tight for $\omega(G) \in \{4, 5, 6\}$.

Chapter 2

Coloring $(P_2 + P_3, \overline{P_2 + P_3})$ -free graphs

2.1 Introduction

In this chapter¹, we are interested in some self-complementary classes of graphs which are χ -bounded. Let \mathcal{C} be a hereditary class of graphs. A function $\phi : \mathbb{N} \rightarrow \mathbb{N}$ such that $\phi(1) = 1$ and $\phi(x) \geq x$, for all $x \in \mathbb{N}$ is called a θ -binding function for \mathcal{C} if $\theta(G) \leq \phi(\alpha(G))$, for each $G \in \mathcal{C}$. The class \mathcal{C} is called θ -bounded if there exists a θ -binding function for \mathcal{C} . The smallest/optimal θ -binding function ϕ^* for \mathcal{C} is defined as $\phi^*(x) := \max\{\theta(G) \mid G \in \mathcal{C} \text{ and } \alpha(G) = x\}$. Clearly, a self-complementary hereditary class of graphs \mathcal{C} is χ -bounded if and only if \mathcal{C} is θ -bounded. In particular, if \mathcal{C} is χ -bounded, then the smallest χ -binding function for \mathcal{C} is the same as the smallest θ -binding function for \mathcal{C} . For instance, by a result of Lovász [125], the class of perfect graphs is a self-complementary class of χ -bounded (θ -bounded) graphs where $\phi(x) = x$ is the smallest χ -binding function as well the smallest θ -binding function.

Among other conjectures and problems (some of them are stated in Chapter 1), Gyárfás [81] proposed the following.

Problem 2 ([81]) *For a fixed forest F , assuming that the class of (F, \overline{F}) -free graphs \mathcal{F} is χ -bounded, what is the smallest χ -binding function for \mathcal{F} ?*

Problem 2 is open and seems to be hard even when F is a simple type of forest such as a long path or a subdivided claw. Moreover, in general, for several known χ -bounded classes of graphs, it is often difficult to find smallest χ -binding functions; see [153, 155, 156] for instances. So it is interesting to look at Problem 2 for some special cases, in particular, when F is a forest on at most five vertices. (See Figure 7 for all five-vertex forests.)

Since each forest on at most five vertices is an induced subgraph of a P_9 or a 4-broom, and since the class of P_9 -free graphs and the class of 4-broom-free graphs are χ -bounded [81, 124, 157], clearly the class of (F, \overline{F}) -free graphs \mathcal{F} is χ -bounded when F is a forest on at most five vertices.

¹The results of this chapter are appearing in “A. Char and T. Karthick. *Optimal chromatic bound for $(P_2 + P_3, \overline{P_2 + P_3})$ -free graphs.* **Journal of Graph Theory** 105 (2024) 149–178. <https://doi.org/10.1002/jgt.23009>”

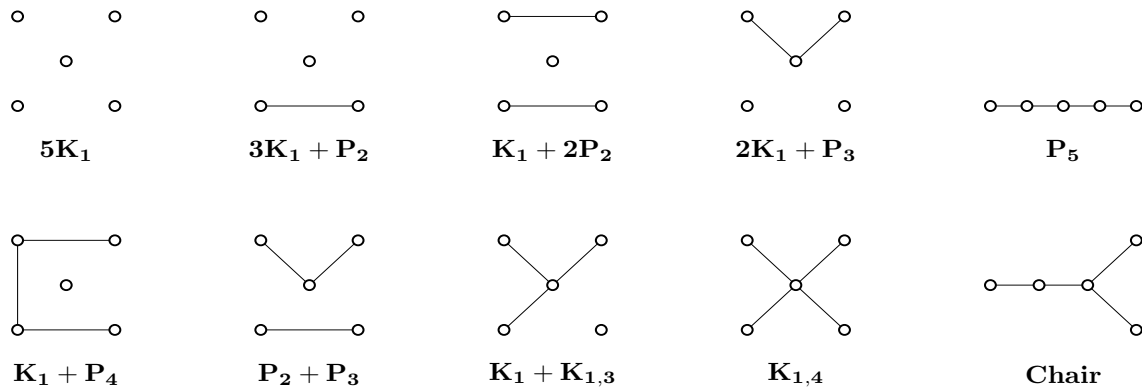

Figure 7: Forests on five vertices.

While smallest χ -binding functions for the class of (F, \overline{F}) -free graphs when F is a forest on at most four vertices are known, except when $F = \overline{K_4}$ [81], only three classes of graphs were studied for Problem 2 when F is a five-vertex forest. We give below some non-trivial known results for Problem 2 when F is a forest on four or five vertices. In this regard, we recall the following known results from Chapter 1.

- Every P_4 -free graph is perfect [159]. The function $f(x) = x + 1$ is the smallest χ -binding function for the class of $(2P_2, C_4)$ -free graphs [9, 81]. Gyárfás [81] showed that if $F \in \{2K_1 + P_2, K_1 + P_3\}$, then $f(x) = \max\{3, x\}$ is the smallest χ -binding function for the class of (F, \overline{F}) -free graphs. He also showed that $f(x) = \lfloor \frac{3x}{2} \rfloor$ is the smallest χ -binding function for the class of $(K_{1,3}, \overline{K_{1,3}})$ -free graphs.
- Every $(P_5, \overline{P_5})$ -free graph G satisfies $\chi(G) \leq (\omega(G)^2)^{+1}$, and there are $(P_5, \overline{P_5})$ -free graphs G with $\chi(G) \geq \omega(G)^k$, where $k = \log_2 5 - 1$ [67]. Karthick and Maffray [101] showed that every $(K_1 + P_4, \overline{K_1 + P_4})$ -free graph G satisfies $\chi(G) \leq \lceil \frac{5}{4}\omega(G) \rceil$, and that the bound is tight.

Recently, Chudnovsky, Cook and Seymour [36] showed that every (chair, Co-chair)-free graph G satisfies $\chi(G) \leq 2\omega(G)$, and that the bound is ‘asymptotically tight’. In 2023, Prashant and Raj [137] showed that every $(2K_1 + P_3, \overline{2K_1 + P_3})$ -free graph G with $\omega(G) \neq 3$ satisfies $\chi(G) \leq \omega(G) + 1$ and that the bound is tight. Furthermore, they showed that every $(2K_1 + P_3, \overline{2K_1 + P_3})$ -free graph G with $\omega(G) = 3$ is 7-colorable. Thus Problem 2 is open and not even attempted for the remaining six pairwise non-isomorphic forests on five vertices. In this chapter, we focus on Problem 2 when $F = P_2 + P_3$. Randerath, Schiermeyer and Tewes [145] studied the class of $(P_2 + P_3, \overline{P_2 + P_3})$ -free graphs which are triangle-free, and showed the following.

Theorem C ([145]) *Every $(P_2 + P_3, \overline{P_2 + P_3})$ -free graph G with $\omega(G) = 2$ satisfies $\chi(G) \leq 4$.*

The well-known Mycielski’s 4-chromatic triangle-free graph or Grötzsch Graph (see Obs. 6 of Table 1) shows that the bound given in Theorem C is tight. However, no smallest χ -binding function is known for the class of $(P_2 + P_3, \overline{P_2 + P_3})$ -free graphs in general.

In this chapter, we show that every $(P_2 + P_3, \overline{P_2 + P_3})$ -free graph G with $\omega(G) \geq 3$ satisfies $\chi(G) \leq \max\{\omega(G) + 3, \lfloor \frac{3}{2}\omega(G) \rfloor - 1\}$, and for any $k \in \mathbb{N}$ and $k \geq 3$, there is a $(P_2 + P_3, \overline{P_2 + P_3})$ -free graph G such that $\omega(G) = k$ and $\chi(G) = \max\{k + 3, \lfloor \frac{3k}{2} \rfloor - 1\}$. More precisely, we show that the function $g : \mathbb{N} \rightarrow \mathbb{N}$ defined by

$$g(1) = 1, g(2) = 4, \text{ and } g(x) = \max\left\{x + 3, \left\lfloor \frac{3x}{2} \right\rfloor - 1\right\}, \text{ for } x \geq 3,$$

is the smallest χ -binding (or θ -binding) function for the class of $(P_2 + P_3, \overline{P_2 + P_3})$ -free graphs.

A vertex v in a graph G is a *nice vertex* if $d_G(v) \leq \omega(G) + 2$. (We drop the subscript G when the relevant graph is unambiguous.) Recall that a graph G is nice if it has three pairwise disjoint stable sets, say S_1, S_2 and S_3 , such that $\omega(G - (S_1 \cup S_2 \cup S_3)) \leq \omega(G) - 2$.

We say that a graph G is *good*, if at least one of the following hold: (a) G has twins. (b) G has a universal vertex. (c) G has a nice vertex. (d) G is a nice graph. (e) $\chi(G) \leq \omega(G) + 3$.

Since $P_2 + P_3$ is an induced subgraph of a P_6 , we use the following result of Karthick and Maffray [102] which solves the case whenever a $(P_2 + P_3, \overline{P_2 + P_3})$ -free graph does not contain a C_4 :

Theorem D ([102]) *Every (P_6, C_4) -free graph G satisfies $\chi(G) \leq \lfloor \frac{5}{4}\omega(G) \rfloor$.*

So to prove our smallest χ -binding function for the class of $(P_2 + P_3, \overline{P_2 + P_3})$ -free graphs, it is enough to consider $(P_2 + P_3, \overline{P_2 + P_3})$ -free graphs that contain a C_4 . The proof of our result follows from our structural result for the class of $(P_2 + P_3, \overline{P_2 + P_3})$ -free graphs that contain a C_4 . Indeed, we show that whenever a $(P_2 + P_3, \overline{P_2 + P_3})$ -free graph contains a C_4 , then it is a good graph.

To prove our structural result, first we prove some structural properties of $(P_2 + P_3, \overline{P_2 + P_3})$ -free graphs that contain a C_4 .

2.2 Properties of $(P_2 + P_3, \overline{P_2 + P_3})$ -free graphs that contain a C_4

Let G be a $(P_2 + P_3, \overline{P_2 + P_3})$ -free graph. Suppose that G contains a C_4 , say with vertex-set $C := \{v_1, v_2, v_3, v_4\}$ and edge-set $\{v_1v_2, v_2v_3, v_3v_4, v_4v_1\}$. For $i \in \{1, 2, 3, 4\}$, $i \bmod 4$ and $j \in \{1, 2\}$, we let:

$$\begin{aligned} A_i &:= \{v \in V(G) \setminus C \mid N(v) \cap C = \{v_i\}\}, \\ B_i &:= \{v \in V(G) \setminus C \mid N(v) \cap C = \{v_i, v_{i+1}\}\}, \\ X_j &:= \{v \in V(G) \setminus C \mid N(v) \cap C = \{v_j, v_{j+2}\}\}, \\ D &:= \{v \in V(G) \setminus C \mid N(v) \cap C = C\}, \text{ and} \\ T &:= \{v \in V(G) \setminus C \mid N(v) \cap C = \emptyset\}. \end{aligned}$$

We let $A := A_1 \cup A_2 \cup A_3 \cup A_4$, $B := B_1 \cup B_2 \cup B_3 \cup B_4$, and $X := X_1 \cup X_2$. From now on and throughout this chapter, our indices of A , B , X and v are taken arithmetic modulo 4 (unless stated otherwise). Since G does not induce a $\overline{P_2 + P_3}$, no vertex in $V(G) \setminus C$ is adjacent to exactly three vertices in C , and hence $V(G) \setminus C = A \cup B \cup D \cup X \cup T$. Further, the graph G has more properties which give in Lemmas 2.1 to 2.6.

Lemma 2.1 *For $i \in \{1, 2, 3, 4\}$, the following hold:*

- (i) $A_i \cup T$ is a stable set.
- (ii) Any vertex in $A_i \cup B_i$ has at most one non-neighbor in $A_{i+2} \cup B_{i+1}$. Likewise, any vertex in $A_{i+1} \cup B_i$ has at most one non-neighbor in $B_{i-1} \cup A_{i-1}$.
- (iii) For any vertex $p \in A_i \cup B_i \cup T$, $N(p) \cap (D \cup B_{i+2})$ is a clique. Likewise, for any $p \in A_i$, $N(p) \cap B_{i+1}$ is a clique. Moreover, for any $p \in A_i$, $|N(p) \cap B_{i+2}| \leq 1$. Likewise, $|N(p) \cap B_{i+1}| \leq 1$.
- (iv) For $j \in \{1, 2\}$, if there are adjacent vertices, say $p \in A_i$ and $q \in A_{i+1}$, then any vertex in X_j is adjacent to exactly one of p and q .
- (v) Further assume that G is $K_{2,3}$ -free. Then any vertex in B_i has at most one neighbor in $A_{i-1} \cup B_{i+2}$. Likewise, any vertex in B_i has at most one neighbor in $A_{i+2} \cup B_{i+2}$.

Proof. (i): If there are adjacent vertices in $A_i \cup T$, say p and q , then $\{p, q, v_{i+1}, v_{i+2}, v_{i+3}\}$ induces a $P_2 + P_3$. So Lemma 2.1:(i) holds. ■

(ii): Let $p \in A_i \cup B_i$. If p has two non-neighbors in $A_{i+2} \cup B_{i+1}$, say q and r , then since $\{p, v_i, q, v_{i+2}, r\}$ does not induce a $P_2 + P_3$, we have $qr \in E(G)$, and then $\{q, r, p, v_i, v_{i+3}\}$ induces a $P_2 + P_3$. So Lemma 2.1:(ii) holds, since p is arbitrary. ■

(iii): If there are non-adjacent vertices in $N(p) \cap (D \cup B_{i+2})$, say d_1 and d_2 , then $\{p, d_1, v_{i+2}, d_2, v_{i+3}\}$ induces a $\overline{P_2 + P_3}$. So the first assertion of Lemma 2.1:(iii) holds. Next if there are vertices, say $b, b' \in N(p) \cap B_{i+2}$, then by the first assertion, $\{p, v_i, v_{i+3}, b, b'\}$ induces a $\overline{P_2 + P_3}$. So the second assertion Lemma 2.1:(iii) holds. ■

(iv): We prove for $j = 1$. For any $x \in X_1$, if $px, qx \in E(G)$, then $\{q, x, v_i, v_{i+1}, p\}$ induces a $\overline{P_2 + P_3}$, and if $px, qx \notin E(G)$, then $\{p, q, x, v_{i+2}, v_{i+3}\}$ induces a $P_2 + P_3$. So x is adjacent to exactly one of p and q . ■

(v): If there is a vertex, say $p \in B_i$, which has two neighbors in $A_{i-1} \cup B_{i+2}$, say q and r , then $\{p, v_i, v_{i-1}, q, r\}$ induces a $K_{2,3}$ or a $\overline{P_2 + P_3}$. So Lemma 2.1:(v) holds. □

Lemma 2.2 *For $j \in \{1, 2\}$, the following hold:*

- (i) If there are adjacent vertices, say $b \in B_j$ and $b' \in B_{j+2}$, then $N(b) \cap (B_{j+1} \cup B_{j-1} \cup D) = N(b') \cap (B_{j+1} \cup B_{j-1} \cup D)$.
- (ii) X_j is a stable set.
- (iii) Any vertex in $A_j \cup A_{j+2}$ has at most one neighbor in X_j .

Proof. (i): If there is a vertex, say $v \in N(b) \cap (B_{j+1} \cup B_{j-1} \cup D)$ such that $v \notin N(b') \cap (B_{j+1} \cup B_{j-1} \cup D)$, then we may suppose (up to symmetry) that $v \in B_{j+1} \cup D$, and then $\{b, v_{j+1}, v_{j+2}, b', v\}$ induces a $\overline{P_2 + P_3}$. So Lemma 2.2:(i) holds. ■

(ii): If there are adjacent vertices in X_j , say p and q , then $\{v_j, v_{j+1}, v_{j+2}, p, q\}$ induces a $\overline{P_2 + P_3}$. So Lemma 2.2:(ii) holds. ■

(iii): If there is a vertex, say $a \in A_j \cup A_{j+2}$, which has two neighbors in X_j , say x and x' , then $\{v_j, x, v_{j+2}, x', a\}$ induces a $\overline{P_2 + P_3}$ (by Lemma 2.2:(ii)). So Lemma 2.2:(iii) holds. □

Lemma 2.3 *The following hold:*

(i) B is anticomplete to X .

(ii) $G[D]$ is $(K_1 + K_2)$ -free, and hence perfect. Moreover, $\chi(G[D]) = \omega(G[D]) \leq \omega(G) - 2$.

(iii) X is complete to D .

Proof. (i): By symmetry, it is enough to show that $B_1 \cup B_2$ is anticomplete to X_1 . Now if there are adjacent vertices, say $b \in B_1 \cup B_2$ and $x \in X_1$, then $\{v_1, v_2, v_3, x, b\}$ induces a $\overline{P_2 + P_3}$. So $B_1 \cup B_2$ is anticomplete to X_1 . ■

(ii): If there are vertices, say p, q and r in D such that $\{p, q, r\}$ induces a $K_1 + K_2$, then $\{p, q, r, v_2, v_4\}$ induces a $\overline{P_2 + P_3}$; so $G[D]$ is $(K_1 + K_2)$ -free. Hence $G[D]$ is perfect. This proves the first assertion of Lemma 2.3:(ii). Since D is complete to $\{v_1, v_2\}$, clearly $\omega(G[D]) \leq \omega(G) - 2$, and hence from the first assertion, we have $\chi(G[D]) = \omega(G[D]) \leq \omega(G) - 2$. This proves the second assertion of Lemma 2.3:(ii). ■

(iii): If there are non-adjacent vertices, say $d \in D$ and $x \in X$, then we may suppose that $x \in X_1$, and then $\{v_1, v_2, v_3, x, d\}$ induces a $\overline{P_2 + P_3}$. So Lemma 2.3:(iii) holds. □

Lemma 2.4 *Let $j, k \in \{1, 2\}$ and $j \neq k$. Assume that there are adjacent vertices, say $p \in A_j$ and $q \in A_{j+2}$. Then:*

(i) *At most one vertex in A_{j+1} is anticomplete to $\{p, q\}$. Likewise, at most one vertex in A_{j-1} is anticomplete to $\{p, q\}$.*

(ii) *At most one vertex in X_k is complete to $\{p, q\}$.*

(iii) *Each vertex in $D \cup X_k$ is adjacent to at least one of p, q .*

Proof. We proof the lemma for $j = 1$ and $k = 2$.

(i): If there are vertices, say $r, s \in A_2$, such that $\{r, s\}$ is anticomplete to $\{p, q\}$, then $\{p, q, r, v_2, s\}$ induces a $P_2 + P_3$ (by Lemma 2.1:(i)). So at most one vertex in A_2 is anticomplete to $\{p, q\}$. Likewise, at most one vertex in A_4 is anticomplete to $\{p, q\}$. ■

(ii): If there are vertices, say $x, x' \in X_2$, such that $\{x, x'\}$ is complete to $\{p, q\}$, then $\{p, x, v_2, x', q\}$ induces a $\overline{P_2 + P_3}$ (by Lemma 2.2:(ii)). So Lemma 2.4:(ii) holds. ■

(iii): If there is a vertex, say $r \in D \cup X_2$, such that $pr, qr \notin E(G)$, then $\{p, q, v_2, r, v_4\}$ induces a $P_2 + P_3$. So Lemma 2.4:(iii) holds. □

Lemma 2.5 *Further if G is $(K_2 + K_3)$ -free, then for $i \in \{1, 2, 3, 4\}$, the following hold:*

- (i) *Any vertex in $A_i \cup B_i$ has at most one non-neighbor in $B_{i+1} \cup B_{i+2}$. Likewise, any vertex in $A_{i+1} \cup B_i$ has at most one non-neighbor in $B_{i-1} \cup B_{i+2}$.*
- (ii) *Any vertex in $A_i \cup B_i \cup T$ has at most one neighbor in $A_{i+1} \cup B_i$. Likewise, any vertex in $A_{i+1} \cup B_i$ has at most one neighbor in $A_i \cup B_i \cup T$.*

Proof. (i): If there is a vertex, say $p \in A_i \cup B_i$, which has two non-neighbors in $B_{i+1} \cup B_{i+2}$, say q and r , then $\{p, v_i, q, v_{i+2}, r\}$ induces a $K_2 + K_3$ or a $P_2 + P_3$. So Lemma 2.5:(i) holds. ■

(ii): If there is a vertex, say $p \in A_i \cup B_i \cup T$, which has two neighbors in $A_{i+1} \cup B_i$, say q and r , then $\{v_{i+2}, v_{i+3}, p, q, r\}$ induces a $K_2 + K_3$ or a $P_2 + P_3$. So Lemma 2.5:(ii) holds. □

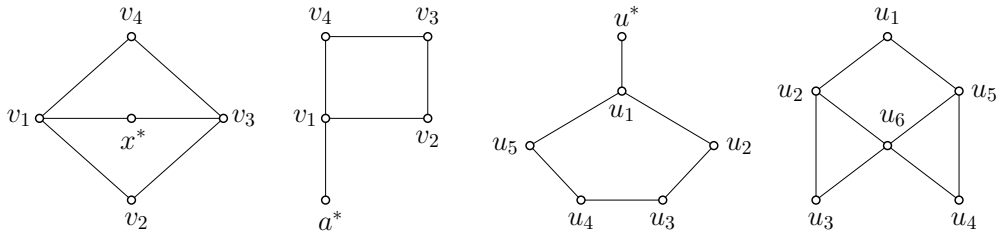

Figure 8: Labelled graphs I: A $K_{2,3}$, a banner, an H_2 and an H_3 (left to right).

Lemma 2.6 *Further if G is Co-banner-free (see Figure 2), then for $i \in \{1, 2, 3, 4\}$, the following hold:*

- (i) *$A_i \cup B_i$ and $A_{i+1} \cup B_i$ are stable sets.*
- (ii) *$A_i \cup B_i \cup A_{i+1}$ is complete to B_{i+2} . Moreover, if $A_i \cup B_i \cup A_{i+1} \neq \emptyset$, then $|B_{i+2}| \leq 1$.*

Proof. (i): If there are adjacent vertices in $A_i \cup B_i$, say p and q , then $\{p, q, v_i, v_{i+3}, v_{i+2}\}$ induces a Co-banner. So $A_i \cup B_i$ is a stable set. Likewise, $A_{i+1} \cup B_i$ is a stable set. So Lemma 2.6:(i) holds. ■

(ii): If there are non-adjacent vertices, say $p \in A_i \cup B_i \cup A_{i+1}$ and $q \in B_{i+2}$, then $\{q, v_{i+2}, v_{i+3}, v_i, p\}$ or $\{q, v_{i+2}, v_{i+3}, v_{i+1}, p\}$ induces a Co-banner; so $A_i \cup B_i \cup A_{i+1}$ is complete to B_{i+2} . This proves the first assertion of Lemma 2.6:(ii). Now since B_{i+2} is a clique (by Lemma 2.1:(iii)), $|B_{i+2}| \leq 1$ (by Lemma 2.6:(i)). So the second assertion of Lemma 2.6:(ii) holds. □

2.3 $(P_2 + P_3, \overline{P_2 + P_3})$ -free graphs that contain a $K_{2,3}$

In this section, we show that if our graph contains a $K_{2,3}$, then it is a good graph. In particular, we prove the following.

Theorem 2.7 *If G is a $(P_2 + P_3, \overline{P_2 + P_3})$ -free graph that contains a $K_{2,3}$, then $\chi(G) \leq \omega(G) + 3$.*

Proof. Let G be a $(P_2 + P_3, \overline{P_2 + P_3})$ -free graph that contains a $K_{2,3}$. We may consider a $K_{2,3}$ with vertices and edges as shown in Figure 8. Let $C := \{v_1, v_2, v_3, v_4\}$. We partition $V(G) \setminus C$ as

in Section 2.2, and we use the lemmas in Section 2.2. Note that by the definition of X_1 , $x^* \in X_1$; so $X_1 \neq \emptyset$. First suppose that $\omega(G) = 2$. Then since G is triangle-free, clearly we have $B \cup D = \emptyset$, A_1 is anticomplete to X_1 , and A_2 is anticomplete to X_2 . Now we let $S_1 := A_1 \cup X_1 \cup \{v_2, v_4\}$, $S_2 := A_2 \cup X_2 \cup \{v_1, v_3\}$, $S_3 := A_3 \cup T$ and $S_4 := A_4$. Then $V(G) = \bigcup_{i=1}^4 S_i$. Clearly S_1, S_2, S_3 and S_4 are stable sets (by Lemma 2.1:(i) and Lemma 2.2:(ii)). Thus $\chi(G) \leq 4 \leq \omega(G) + 3$, and we are done. So suppose that $\omega(G) \geq 3$. Now we have the following claims:

2.7.1 For $i \in \{1, 2, 3, 4\}$, B_i is a stable set.

Proof of 2.7.1. If there are adjacent vertices in B_i , say p and q , then $\{p, q, x^*, v_{i+2}, v_{i+3}\}$ induces a $P_2 + P_3$ (by Lemma 2.3:(i)). So 2.7.1 holds. ■

2.7.2 A_2 is anticomplete to $B_1 \cup B_2$, and A_4 is anticomplete to $B_3 \cup B_4$.

Proof of 2.7.2. Using symmetry, we prove that A_2 is anticomplete to B_1 in the first assertion. Suppose there are adjacent vertices, say $a \in A_2$ and $b \in B_1$. By Lemma 2.3:(i), $bx^* \notin E(G)$. Now since $\{a, b, x^*, v_3, v_4\}$ does not induce a $P_2 + P_3$, we have $ax^* \in E(G)$, and then $\{a, x^*, v_1, v_2, b\}$ induces a $\overline{P_2 + P_3}$. So A_2 is anticomplete to B_1 . ■

First suppose that $\omega(G[D]) \leq \omega(G) - 3$. Now we let $S_1 := A_1 \cup T \cup \{v_2, v_4\}$, $S_2 := B_1 \cup X_1$, $S_3 := A_2 \cup B_2$, $S_4 := A_3 \cup \{v_1\}$, $S_5 := B_3 \cup X_2$ and $S_6 := A_4 \cup B_4 \cup \{v_3\}$. Then $V(G) \setminus D = \bigcup_{i=1}^6 S_i$. Also from Lemma 2.1:(i), Lemma 2.2:(ii), Lemma 2.3:(i), and from 2.7.1 and 2.7.2, we conclude that S_1, S_2, \dots, S_6 are stable sets. Hence $\chi(G) \leq \chi(G[D]) + 6 \leq (\omega(G) - 3) + 6 = \omega(G) + 3$ (by Lemma 2.3:(ii)), and we are done. So assume that $\omega(G[D]) = \omega(G) - 2$ (by Lemma 2.3:(ii)). Then since $\omega(G) \geq 3$, $D \neq \emptyset$. Let $A'_1 := \{a \in A_1 \mid a \text{ has a neighbor in } X_1\}$, and we claim the following.

2.7.3 A'_1 is anticomplete to X_2 .

Proof of 2.7.3. Suppose to the contrary that there exist adjacent vertices, say $a \in A'_1$ and $x \in X_2$. By the definition of A'_1 , there is a vertex $x' \in X_1$ such that $ax' \in E(G)$. Recall that D is complete to X (by Lemma 2.3:(iii)) and $\omega(G[D]) = \omega(G) - 2$. Also for any $d \in D$, since $\{a, v_1, v_2, x, d\}$ does not induce a $\overline{P_2 + P_3}$, we observe that D is complete to $\{a\}$, and so D is a clique (by Lemma 2.1:(iii)). Then $D \cup \{a, v_1, x'\}$ is a clique of size $\omega(G) + 1$, a contradiction. So 2.7.3 holds. ■

2.7.4 B_1 is anticomplete to B_2 . Likewise B_3 is anticomplete to B_4 .

Proof of 2.7.4. Suppose to the contrary that there exist adjacent vertices, say $b_1 \in B_1$ and $b_2 \in B_2$. Note that for any $d \in D$, since $\{b_1, b_2, x^*, d, v_4\}$ does not induce a $P_2 + P_3$ (by Lemma 2.3:(i) and Lemma 2.3:(iii)), d is adjacent to one of b_1 and b_2 . We let $D_1 := \{d \in D \mid db_1 \in E(G), db_2 \notin E(G)\}$, $D_2 := \{d \in D \mid db_2 \in E(G), db_1 \notin E(G)\}$ and $D_3 := \{d \in D \mid db_1, db_2 \in E(G)\}$ so that $D = D_1 \cup D_2 \cup D_3$. Now if there are adjacent vertices, say $d_1 \in D_1$ and $d_2 \in D_2$, then $\{b_1, d_1, d_2, b_2, v_3\}$ induces a $\overline{P_2 + P_3}$; so D_1 is anticomplete to D_2 . Moreover, by Lemma 2.1:(iii), it follows that $D_1 \cup D_3 (= N(b_1) \cap D)$ and $D_2 \cup D_3 (= N(b_2) \cap D)$ are cliques. Thus we conclude that

any maximum clique in $G[D]$ is either $D_1 \cup D_3$ or $D_2 \cup D_3$; so $\max\{|D_1 \cup D_3|, |D_2 \cup D_3|\} = \omega(G) - 2$. Then since $D_1 \cup D_3 \cup \{b_1, v_1, v_2\}$ and $D_2 \cup D_3 \cup \{b_2, v_2, v_3\}$ are cliques, at least one of them is a clique of size $(\omega(G) - 2) + 3 = \omega(G) + 1$, a contradiction. This proves 2.7.4. ■

Now we let $S_1 := A_2 \cup B_1 \cup B_2 \cup \{v_4\}$, $S_2 := A_4 \cup B_3 \cup B_4 \cup \{v_2\}$, $S_3 := A'_1 \cup X_2 \cup \{v_3\}$, $S_4 := (A_1 \setminus A'_1) \cup X_1$ and $S_5 := A_3 \cup T \cup \{v_1\}$. Then $V(G) \setminus D = \bigcup_{i=1}^5 S_i$. Also, from 2.7.1, 2.7.2 and 2.7.3, and from Lemma 2.1:(i) and Lemma 2.2:(ii), we see that S_1, S_2, \dots, S_5 are stable sets. So $\chi(G) \leq \chi(G[D]) + \chi(G[V(G) \setminus D]) \leq (\omega(G) - 2) + 5 \leq \omega(G) + 3$ (by Lemma 2.3:(ii)). □

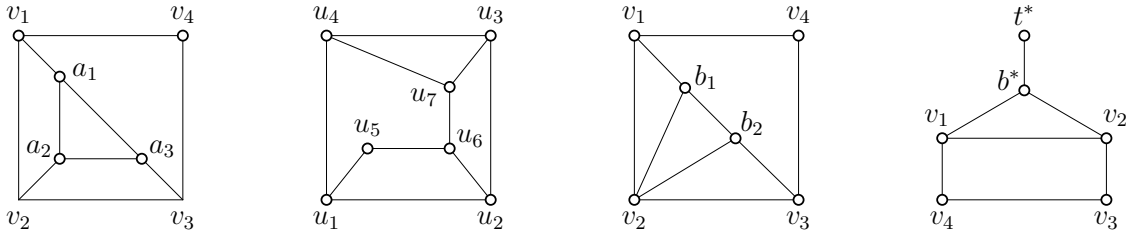

Figure 9: Labelled graphs II: An H_1 , $\overline{H_1}$, $\overline{H_2}$, and an $\overline{H_3}$ (left to right).

By Theorem 2.7, it is enough to show that given a graph G which is $(P_2 + P_3, \overline{P_2 + P_3}, K_{2,3})$ -free, G is a good graph. We will show that G is a good graph based on a sequence of partial results which depend on some special graphs; see Figures 8 and 9. More precisely, given a $(P_2 + P_3, \overline{P_2 + P_3}, K_{2,3})$ -free graph G , we will show that the following hold:

- (a) If G contains a banner, then G is a good graph (Theorem 2.13).
- (b) If G is banner-free and contains an H_2 , then G is a good graph (Theorem 2.14).
- (c) If G is (banner, H_2)-free and contains an H_3 , then G is a good graph (Theorem 2.26).
- (d) If G contains a C_4 , then G is a good graph (Theorem 2.30).

2.4 $(P_2 + P_3, \overline{P_2 + P_3}, K_{2,3})$ -free graphs that contain some special graphs

2.4.1 $(P_2 + P_3, \overline{P_2 + P_3}, K_{2,3})$ -free graphs that contain a banner

In this section, we prove that if G is a $(P_2 + P_3, \overline{P_2 + P_3}, K_{2,3})$ -free graph that contains a banner, then G is a good graph. As an intermediate step, we prove that if our graph contains an $\overline{H_1}$, then it is a good graph.

We start with the following. Let G be a $(P_2 + P_3, \overline{P_2 + P_3}, K_2 + K_3)$ -free graph that contains an H_1 . We may consider an H_1 with vertices and edges as shown in Figure 9. Let $C := \{v_1, v_2, v_3, v_4\}$. We partition $V(G) \setminus C$ as in Section 2.2, and we use the lemmas in Section 2.2. Clearly $a_1 \in A_1$, $a_2 \in A_2$ and $a_3 \in A_3$. To proceed further, we partition the vertex-set A_4 as follows:

$$\begin{aligned} L_1 &:= \{a \in A_4 \mid aa_2 \in E(G) \text{ and } N(a) \cap \{a_1, a_3\} \neq \emptyset\}, \\ L_2 &:= \{a \in A_4 \mid aa_2 \in E(G) \text{ and } N(a) \cap \{a_1, a_3\} = \emptyset\}, \text{ and} \\ L_3 &:= \{a \in A_4 \mid aa_2 \notin E(G)\}. \end{aligned}$$

Then clearly $A_4 = L_1 \cup L_2 \cup L_3$, $|L_2| \leq 1$ (by Lemma 2.4:(i)), and $|L_3| \leq 1$ (by Lemma 2.1:(ii)). So if $L_1 = \emptyset$, then $|A_4| \leq 2$. Moreover, the graph G has some more properties which we give in Lemmas 2.8 to 2.11 below.

Lemma 2.8 *The following hold:*

- (i) $A_1 \setminus \{a_1\}$ is complete to $\{a_3\}$. Likewise, $A_3 \setminus \{a_3\}$ is complete to $\{a_1\}$.
- (ii) $(A_1 \setminus \{a_1\}) \cup (A_3 \setminus \{a_3\})$ is anticomplete to $\{a_2\}$, and is complete to $(A_2 \setminus \{a_2\}) \cup L_2$.
- (iii) If $(A_2 \setminus \{a_2\}) \cup L_2 \neq \emptyset$, then $|A_1 \setminus \{a_1\}| \leq 1$ and $|A_3 \setminus \{a_3\}| \leq 1$.
- (iv) X_2 is an empty set. Likewise, if $L_1 \neq \emptyset$, then X_1 is an empty set.

Proof. (i): For any $a'_1 \in A_1 \setminus \{a_1\}$, by Lemma 2.5:(ii), $a_2a'_1 \notin E(G)$, and then since $\{a_2, a_3, a'_1, v_1, v_4\}$ does not induce a $P_2 + P_3$, we have $a'_1a_3 \in E(G)$; so $A_1 \setminus \{a_1\}$ is complete to $\{a_3\}$. So Lemma 2.8:(i) holds. ■

(ii): Clearly the first assertion of Lemma 2.8:(ii) follows from Lemma 2.5:(ii). If there are non-adjacent vertices, say $a'_1 \in A_1 \setminus \{a_1\}$ and $a'_2 \in A_2 \setminus \{a_2\}$, then $\{a'_2, v_2, a_1, a_3, a'_1\}$ induces a $P_2 + P_3$ (by Lemma 2.5:(ii) and Lemma 2.8:(i)); so $A_1 \setminus \{a_1\}$ is complete to $A_2 \setminus \{a_2\}$. Likewise, $A_3 \setminus \{a_3\}$ is complete to $A_2 \setminus \{a_2\}$. If there are non-adjacent vertices, say $a' \in A_1 \setminus \{a_1\}$ and $a \in L_2$, then $\{a, v_4, a_1, a_3, a'\}$ induces a $P_2 + P_3$ (by Lemma 2.8:(i)); so $A_1 \setminus \{a_1\}$ is complete to L_2 . Likewise, $A_3 \setminus \{a_3\}$ is complete to L_2 . So Lemma 2.8:(ii) holds. ■

(iii): The proof of Lemma 2.8:(iii) follows from Lemma 2.8:(ii) and Lemma 2.5:(ii). ■

(iv): Suppose to the contrary that there is a vertex, say $x \in X_2$. By Lemma 2.4:(iii), we may suppose that $a_1x \in E(G)$. Then $a_2x \notin E(G)$ and $a_3x \in E(G)$ (by Lemma 2.1:(iv)), and then $\{a_1, a_2, v_2, x, a_3\}$ induces a $\overline{P_2 + P_3}$, a contradiction; so $X_2 = \emptyset$. So Lemma 2.8:(iv) holds. □

Lemma 2.9 *The following hold:*

- (i) B_1 is anticomplete to $\{a_1, a_2\}$, and B_2 is anticomplete to $\{a_2, a_3\}$. Moreover, B_1 is complete to $\{a_3\}$, and B_2 is complete to $\{a_1\}$; so $|B_1| \leq 1$ and $|B_2| \leq 1$.
- (ii) $|B_3| \leq 2$ and $|B_4| \leq 2$. Further, if $|B_3| = 2$, then $|B_4| \leq 1$ and vice versa.
- (iii) D is complete to $\{a_1, a_2, a_3\}$, and D is a clique.

Proof. (i): The first statement follows from Lemma 2.5:(ii). Now for any $b \in B_1$, since $\{a_2, a_3, b, v_1, v_4\}$ does not induce a $P_2 + P_3$, B_1 is complete to $\{a_3\}$; so $|B_1| \leq 1$ (by Lemma 2.1:(iii)). Likewise, B_2 is complete to $\{a_1\}$, and $|B_2| \leq 1$. So Lemma 2.9:(i) holds. ■

(ii): Clearly a_2 has at most one non-neighbor in $B_3 \cup B_4$ (by Lemma 2.1:(ii)), and has at most one neighbor in B_3 (by Lemma 2.1:(iii)). Also a_2 has at most one neighbor in B_4 (by Lemma 2.1:(iii)). So $|B_3| \leq 2$ and $|B_4| \leq 2$, and if $|B_3| = 2$ then $|B_4| \leq 1$ and vice versa. This proves Lemma 2.9:(ii). ■

(iii): Let $d \in D$ be arbitrary. Then since $\{v_1, a_1, a_2, v_2, d\}$ does not induce a $\overline{P_2 + P_3}$, we have $da_1, da_2 \notin E(G)$ or $da_1, da_2 \in E(G)$. If $da_1, da_2 \notin E(G)$, then $\{a_1, a_2, d, v_3, v_4\}$ induces a $K_2 + K_3$. So we have $da_1, da_2 \in E(G)$. Since $\{a_2, a_3, v_3, v_2, d\}$ does not induce a $\overline{P_2 + P_3}$, we have $da_3 \in E(G)$. Hence D is complete to $\{a_1, a_2, a_3\}$, and so D is a clique (by Lemma 2.1:(iii)). This proves Lemma 2.9:(iii), since d is arbitrary. \square

Lemma 2.10 *The following hold:*

(i) $\theta(G[B \cup C]) \leq 3$.

(ii) $\theta(G[L_3 \cup B \cup C \cup D \cup \{a_1, a_2, a_3\}]) \leq 4$.

Proof. (i): We restrict ourselves to the graph $G[B \cup C]$, and we apply Lemma 2.9. From Lemma 2.9:(ii), we have $|B_4| \leq 1$. First assume that there are non-adjacent vertices, say $b_3 \in B_3$ and $b_2 \in B_2$. Then $\{b_2\}$ is complete to $(B_3 \setminus \{b_3\}) \cup B_4$ (by Lemma 2.5:(i)), and then B_4 is complete to $(B_3 \setminus \{b_3\})$ (by Lemma 2.2:(i)). So $\{b_2\} \cup (B_3 \setminus \{b_3\}) \cup B_4$, $\{b_3, v_3, v_4\}$ and $B_1 \cup \{v_1, v_2\}$ are cliques, and thus $\theta(G[B \cup C]) \leq 3$. Hence suppose that B_3 is complete to $B_2 \cup B_4$. Then clearly $\theta(G[B_2 \cup B_3 \cup B_4 \cup \{v_3, v_4\}]) \leq 2$, and since $B_1 \cup \{v_1, v_2\}$ is a clique, we have $\theta(G[B \cup C]) \leq 3$. \blacksquare

(ii): If $L_3 = \emptyset$, then since $D \cup \{a_1, a_2, a_3\}$ is a clique (by Lemma 2.9:(iii)), we see that $\theta(G[L_3 \cup B \cup C \cup D \cup \{a_1, a_2, a_3\}]) \leq \theta(G[B \cup C]) + 1 \leq 4$ (by Lemma 2.10:(i)), and we are done. So $L_3 \neq \emptyset$, and let $L_3 := \{a^*\}$. Then since $\{a_1, a_2, a^*, v_4, v_3\}$ does not induce a $P_2 + P_3$, $a_1 a^* \in E(G)$. Likewise, $a_3 a^* \in E(G)$. Since $a_3 a^* \in E(G)$, $\{a^*\}$ is anticomplete to B_3 (by Lemma 2.5:(ii)). Then since for any $b \in B_3$, $\{a_1, a^*, b, v_3, v_2\}$ does not induce a $P_2 + P_3$, $\{a_1\}$ is complete to B_3 . Likewise, $\{a^*\}$ is complete to B_1 . Also since $a_2 a^* \notin E(G)$, $\{a_2\}$ is complete to $B_3 \cup B_4$ (by Lemma 2.1:(ii)). So $|B_3| \leq 1$ and $|B_4| \leq 1$ (by Lemma 2.1:(iii)). Also if there are non-adjacent vertices, say $d \in D$ and $b \in B_3$, then $\{b, a_1, d, v_4, v_1\}$ induces a $\overline{P_2 + P_3}$ (by Lemma 2.9:(iii)); so D is complete to B_3 . Thus from Lemma 2.9, $\{a^*\} \cup B_1 \cup \{a_3\}$, $B_3 \cup D \cup \{a_1, a_2\}$, $B_2 \cup \{v_2, v_3\}$ and $B_4 \cup \{v_1, v_4\}$ are cliques, and hence $\theta(G[L_3 \cup B \cup C \cup D \cup \{a_1, a_2, a_3\}]) \leq 4$. \square

Lemma 2.11 *If $L_1 \neq \emptyset$, then $\theta(G) \leq \alpha(G) + 3$.*

Proof. Let $a_4 \in L_1$. We may suppose that $a_1 a_4 \in E(G)$. Then we have $X_1 \cup X_2 = \emptyset$ (by Lemma 2.8:(iv)). So, by Lemma 2.10:(i), it is enough to show that $\theta(G[A \cup D \cup T]) \leq \alpha(G)$. Recall that $D \cup \{a_1, a_2, a_3\}$ is a clique. Since for any $d \in D$, $\{a_1, a_4, v_4, v_1\}$ does not induce a $\overline{P_2 + P_3}$, D is complete to $\{a_4\}$. Also:

2.11.1 *We may assume that $(A_2 \setminus \{a_2\}) \cup (A_4 \setminus \{a_4\}) \neq \emptyset$.*

Proof of 2.11.1. If $(A_2 \setminus \{a_2\}) \cup (A_4 \setminus \{a_4\}) = \emptyset$, then since $A_1 \cup A_3 \cup T$ induces a bipartite graph (by Lemma 2.1:(i)), and is anticomplete to $\{v_2, v_4\}$, we have $\theta(G[A_1 \cup A_3 \cup T]) \leq \alpha(G) - 2$, and since $D \cup \{a_2, a_4\}$ is a clique, we conclude that $\theta(G[A \cup D \cup T]) \leq \alpha(G)$, and we are done. \blacksquare

Note that $A_1 \setminus \{a_1\}$ is anticomplete to $\{a_2, a_4\}$ (by Lemma 2.5:(ii)), and so $|A_1 \setminus \{a_1\}| \leq 1$ (by Lemma 2.4:(i)). Next we claim the following.

2.11.2 $|A_3| \leq 2$.

Proof of 2.11.2. If $|A_3| \geq 3$, then from 2.11.1 and Lemma 2.8:(iii), it follows that $A_4 \setminus \{a_4\} \neq \emptyset$, and so for any $a \in A_4 \setminus \{a_4\}$, by Lemma 2.5:(ii), there are vertices $p, q \in A_3$ such that $ap, aq \notin E(G)$, and hence again by Lemma 2.5:(ii) and Lemma 2.8:(i), $\{a, v_4, p, a_1, q\}$ induces a $P_2 + P_3$, a contradiction. So $|A_3| \leq 2$. ■

2.11.3 D is complete to $A_1 \setminus \{a_1\}$. Likewise, D is complete to $A_3 \setminus \{a_3\}$.

Proof of 2.11.3. If there exist non-adjacent vertices, say $a'_1 \in A_1 \setminus \{a_1\}$ and $d \in D$, then $\{v_1, a_1, a_3, a'_1, d\}$ induces a $\overline{P_2 + P_3}$ (by Lemma 2.8:(i) and Lemma 2.1:(i)). So D is complete to $A_1 \setminus \{a_1\}$. Likewise, D is complete to $A_3 \setminus \{a_3\}$. ■

Hence by 2.11.2, 2.11.3, Lemma 2.8:(i) and Lemma 2.9:(iii), $\theta(G[A_1 \cup A_3 \cup D]) \leq 2$. Also since $A_2 \cup A_4 \cup T$ induces a bipartite graph (by Lemma 2.1:(i)) which is anticomplete to $\{v_1, v_3\}$, $\theta(G[A_2 \cup A_4 \cup T]) \leq \alpha(G) - 2$. Thus $\theta(G[A \cup D \cup T]) \leq \alpha(G)$. This proves Lemma 2.11. □

Theorem 2.12 *If G^* is a $(P_2 + P_3, \overline{P_2 + P_3}, K_{2,3})$ -free graph that contains an $\overline{H_1}$, then $\chi(G^*) \leq \omega(G^*) + 3$.*

Proof. To prove the theorem, we start with the complement graph of G^* , say G , and show that $\theta(G) \leq \alpha(G) + 3$. Now G is a $(P_2 + P_3, \overline{P_2 + P_3}, K_2 + K_3)$ -free graph that contains an H_1 . We may consider an H_1 with vertices and edges as shown in Figure 9. Let $C := \{v_1, v_2, v_3, v_4\}$. We partition $V(G) \setminus C$ as in Section 2.2, and we use the lemmas in Section 2.2. We further partition the set A_4 as in the beginning of this section, and we use Lemmas 2.8 to 2.11. Recall that $X_2 = \emptyset$ (by Lemma 2.8:(iv)). From Lemma 2.4 and Lemma 2.5:(ii), we have $|A_2| \leq 2$. By Lemma 2.11, we may suppose that $L_1 = \emptyset$; so $|A_4| \leq 2$. Now we prove the theorem in two cases as follows:

Case 1 *The set $L_2 \cup (A_2 \setminus \{a_2\})$ is non-empty.*

First suppose that $(A_1 \setminus \{a_1\}) \cup (A_3 \setminus \{a_3\}) = \emptyset$. Let us define $X'_1 := \{x \in X_1 \mid a_1x \in E(G)\}$. Then it follows from Lemma 2.1:(iv) that X'_1 is complete to $\{a_3\}$; so $|X'_1| \leq 1$ (by Lemma 2.2:(iii)). Note that $T \cup (X \setminus X'_1)$ induces a bipartite graph (by Lemma 2.1:(i) and Lemma 2.2:(ii)), and is anticomplete to $\{a_1, v_2, v_4\}$; so $\theta(G[T \cup (X \setminus X'_1)]) \leq \alpha(G) - 3$. Since $|A_2| \leq 2$ and $|A_4| \leq 2$, we have $\theta(G[A_2 \cup A_4]) \leq 2$ (by Lemma 2.1:(ii)). Also $\theta(G[A_1 \cup A_3 \cup D \cup X'_1]) \leq 1$ (by Lemma 2.3:(iii) and Lemma 2.9:(iii)). Hence by Lemma 2.10:(i), $\theta(G) \leq \alpha(G) + 3$, and we are done.

Next suppose that $(A_1 \setminus \{a_1\}) \cup (A_3 \setminus \{a_3\}) \neq \emptyset$. Then $|A_1 \setminus \{a_1\}| \leq 1$ and $|A_3 \setminus \{a_3\}| \leq 1$ (by Lemma 2.8:(iii)). Thus $(A_2 \setminus \{a_2\}) \cup (A_3 \setminus \{a_3\})$ and $(A_1 \setminus \{a_1\}) \cup L_2$ are cliques (by Lemma 2.8:(ii)). So $\theta(G[A \cup B \cup C \cup D]) \leq 6$ (by Lemma 2.10:(ii)). Next we claim that:

2.12.1 X_1 is anticomplete to $\{a_1\}$.

Proof of 2.12.1. Suppose to the contrary that there is a vertex $x \in X_1$ such that $xa_1 \in E(G)$. By Lemma 2.1:(iv), $a_2x \notin E(G)$ and $a_3x \in E(G)$. Let $a' \in (A_1 \setminus \{a_1\}) \cup (A_3 \setminus \{a_3\})$. Then since $\{a_1, v_1, a', a_3, x\}$ or $\{a_1, a_3, v_3, a', x\}$ does not induce a $\overline{P_2 + P_3}$ (by Lemma 2.8:(i)), we have $a'x \in E(G)$. Then by Lemma 2.8:(ii) and by Lemma 2.1:(iv), $\{x\}$ is anticomplete to $(A_2 \setminus \{a_2\}) \cup L_2$. But then for any $a^* \in (A_2 \setminus \{a_2\}) \cup L_2$, one of $\{a^*, v_2, a_1, a_3, x\}$, $\{a^*, v_4, a_1, a_3, x\}$ induces a $K_2 + K_3$. So X_1 is anticomplete to $\{a_1\}$. ■

Since $T \cup X_1$ induces a bipartite graph (by Lemma 2.1:(i) and Lemma 2.2:(ii)), and is anticomplete to $\{a_1, v_2, v_4\}$ (by 2.12.1), clearly $\theta(G[T \cup X_1]) \leq \alpha(G) - 3$. Hence $\theta(G) \leq \theta(G[A \cup B \cup C \cup D]) + \theta(G[T \cup X_1]) \leq 6 + (\alpha(G) - 3) = \alpha(G) + 3$. This complete the proof in Case 1.

Case 2 *The set $L_2 \cup (A_2 \setminus \{a_2\})$ is empty.*

If $(A_1 \setminus \{a_1\}) \cup (A_3 \setminus \{a_3\})$ is a stable set, then since $A_1 \setminus \{a_1\} \cup (A_3 \setminus \{a_3\}) \cup T \cup X_1$ induces a bipartite graph (by Lemma 2.1:(i) and Lemma 2.2:(ii)), and is anticomplete to $\{v_2, v_4\}$, we see that $\theta(G) \leq \theta(G[A_1 \setminus \{a_1\} \cup (A_3 \setminus \{a_3\}) \cup X_1 \cup T]) \leq \alpha(G) - 2$, and the proof follows by using Lemma 2.10:(ii). So suppose that there are adjacent vertices, say $a'_1 \in A_1 \setminus \{a_1\}$ and $a'_3 \in A_3 \setminus \{a_3\}$ (by Lemma 2.1:(i)). Next we claim that:

2.12.2 X_1 is complete to $\{a_2\} \cup L_3$. Moreover, $|X_1| \leq 2$.

Proof of 2.12.2. Suppose that there is a vertex $x \in X_1$ such that $xa_2 \notin E(G)$. Then $a_1x, a_3x \in E(G)$ (by Lemma 2.1:(iv)). Then since $\{v_1, a_1, a_3, a'_1, x\}$ does not induce a $\overline{P_2 + P_3}$ (by Lemma 2.1:(i) and Lemma 2.8:(i)), $a'_1x \in E(G)$. But then $\{a_2, v_2, a'_1, x, a'_3\}$ induces a $K_2 + K_3$ or a $P_2 + P_3$ (by Lemma 2.8:(ii)); so X_1 is complete to $\{a_2\}$. Hence if there are non-adjacent vertices, say $x \in X_1$ and $a \in L_3$, then $\{a, v_4, x, a_2, v_2\}$ induces a $P_2 + P_3$; so X_1 is complete to L_3 . This proves the first assertion of 2.12.2. Next if $|X_1| \geq 3$, then there is a vertex $x \in X_1$ such that $xa'_1, xa'_3 \notin E(G)$ (by Lemma 2.2:(iii)), and then $\{a'_1, a'_3, x, a_2, v_2\}$ induces a $P_2 + P_3$ (by Lemma 2.8:(ii)); so $|X_1| \leq 2$. ■

By using 2.12.2, Lemma 2.3:(iii) and Lemma 2.9:(iii), we have $\theta(G[A_2 \cup L_3 \cup D \cup X_1]) \leq 2$. Also since $A_1 \cup A_3 \cup T$ induces a bipartite graph (by Lemma 2.1:(i)), and is anticomplete to $\{v_2, v_4\}$, clearly $\theta(G[A_1 \cup A_3 \cup T]) \leq \alpha(G) - 2$, and hence the theorem follows from Lemma 2.10:(i). □

Now we prove the main result of this section.

Theorem 2.13 *If G is a $(P_2 + P_3, \overline{P_2 + P_3}, K_{2,3})$ -free graph that contains a banner, then G is a good graph.*

Proof. Let G be a $(P_2 + P_3, \overline{P_2 + P_3}, K_{2,3})$ -free graph that contains a banner. We may consider a banner with vertices and edges as shown in Figure 8. Let $C := \{v_1, v_2, v_3, v_4\}$. We partition $V(G) \setminus C$ as in Section 2.2, and we use the lemmas in Section 2.2. Since G is $K_{2,3}$ -free, clearly $X = \emptyset$. Recall that, by the definition of A_1 , we have $a^* \in A_1$, and so $A \neq \emptyset$. We may assume that

G does not have twins. Moreover, by Theorem 2.12, we may suppose that G is $\overline{H_1}$ -free. Note that if $\chi(G[V(G) \setminus D]) \leq 5$, then $\chi(G) \leq \omega(G) + 3$ (by Lemma 2.3:(ii)). Now we have the following claim.

2.13.1 *If $A_4 \neq \emptyset$, then the set $A_1 \cup A_4 \cup B_1 \cup \{v_3\}$ can be partitioned into two stable sets. Likewise, if $A_4 \neq \emptyset$, then the set $A_3 \cup A_4 \cup B_2 \cup \{v_1\}$ can be partitioned into two stable sets.*

Proof of 2.13.1. If A_4 is anticomplete to B_1 , then from Lemma 2.1:(ii), $|A_4| = 1$ and $|B_1| \leq 1$, and so $A_1 \cup \{v_3\}$ and $A_4 \cup B_1$ are stable sets, and we are done. So there are adjacent vertices, say $a_4 \in A_4$ and $b_1 \in B_1$. Then from Lemma 2.1:(iii) and Lemma 2.1:(v), $\{a_4\}$ is anticomplete to $B_1 \setminus \{b_1\}$, and $A_4 \setminus \{a_4\}$ is anticomplete to $\{b_1\}$. So $(A_4 \setminus \{a_4\}) \cup \{b_1\}$ is a stable set, and from Lemma 2.1:(ii), $|B_1 \setminus \{b_1\}| \leq 1$. Now we show that $A_1 \cup (B_1 \setminus \{b_1\}) \cup \{a_4, v_3\}$ is a stable set. First if there is a vertex, say $a_1 \in A_1$, such that $a_1 a_4 \in E(G)$, then $\{a_1, a_4, v_4, v_1, b_1\}$ induces a $\overline{P_2 + P_3}$ or a $K_{2,3}$; so $A_1 \cup \{a_4\}$ is a stable set. Next if there are adjacent vertices, say $a \in A_1$ and $b \in B_1 \setminus \{b_1\}$, then $\{a_4, v_4, a, b, v_2\}$ induces a $P_2 + P_3$. Thus $A_1 \cup (B_1 \setminus \{b_1\}) \cup \{a_4, v_3\}$ is a stable set. ■

Now we split the proof into two cases based on the subsets of B .

Case 1 *Suppose that B_i and B_{i+2} are non-empty, for some $i \in \{1, 2, 3, 4\}$.*

We let $i = 1$, and we claim the following:

2.13.2 *B_1 is complete to B_3 , and B_2 is complete to B_4 .*

Proof of 2.13.2. Suppose there are non-adjacent vertices, say $b \in B_1$ and $b' \in B_3$. Then since $\{b', v_3, a^*, v_1, b\}$ does not induce a $P_2 + P_3$, either $ba^* \in E(G)$ or $b'a^* \in E(G)$. If $ba^* \in E(G)$, then since $\{b', v_4, a^*, b, v_2\}$ does not induce a $P_2 + P_3$, we have $b'a^* \in E(G)$, and then $\{a^*, b, b'\} \cup C$ induces an $\overline{H_1}$, a contradiction to our assumption that G is $\overline{H_1}$ -free; so $ba^* \notin E(G)$ and $b'a^* \in E(G)$. But then $\{b, v_2, a^*, b', v_4\}$ induces a $P_2 + P_3$. So B_1 is complete to B_3 . Likewise, B_2 is complete to B_4 . So 2.13.2 holds. ■

From Lemma 2.1:(v) and 2.13.2, we have $|B_1| = 1 = |B_3|$, A_1 is anticomplete to B_3 , and A_3 is anticomplete to B_1 . Thus $S_1 := A_1 \cup B_3 \cup \{v_2\}$, $S_2 := A_3 \cup B_1 \cup \{v_4\}$ and $S_3 := A_2 \cup T \cup \{v_1, v_3\}$ are stable sets (by Lemma 2.1:(i)). Now, if B_2 and B_4 are non-empty or if $B_2 \cup B_4 = \emptyset$, then as in the previous argument, B_4 and $A_4 \cup B_2$ are stable sets, and hence $\chi(G[V(G) \setminus D]) \leq 5$, we are done. So $B_2 \neq \emptyset$ and $B_4 = \emptyset$. If $A_4 \neq \emptyset$, then from 2.13.1, $A_4 \cup B_2$ can be partitioned into two stable sets, so $\chi(G[V(G) \setminus D]) \leq 5$, and again we are done. So $A_4 = \emptyset$. Now note that, since $A_4 \cup B_4 = \emptyset$, we have $V(G) \setminus (S_1 \cup S_2 \cup S_3) = B_2 \cup D$. Then since $\{v_2, v_3\}$ is complete to $B_2 \cup D$, we have $\omega(G[B_2 \cup D]) \leq \omega(G) - 2$, and hence G is a nice graph. This proves the theorem in Case 1.

Case 2 For each $i \in \{1, 2, 3, 4\}$, suppose that one of B_i, B_{i+2} is empty.

We may assume that $B_3 \cup B_4 = \emptyset$. Since $N(v_2) = A_2 \cup B_1 \cup B_2 \cup D \cup \{v_1, v_3\}$ and $N(v_4) = A_4 \cup D \cup \{v_1, v_3\}$, and since G does not have twins, we have $A_4 \neq \emptyset$, and let $a_4 \in A_4$. Now if $A_2 = \emptyset$, then since $T \cup \{v_2, v_4\}$ is a stable set (by Lemma 2.1:(i)), from 2.13.1, $\chi(G[V(G) \setminus D]) \leq 5$, and we are done. So $A_2 \neq \emptyset$. First suppose that either $\{a_4\}$ is anticomplete to A_2 or $\{a_4\}$ is anticomplete to B_1 .

2.13.3 We may assume that there are vertices $a_2 \in A_2$ and $b_1 \in B_1$ such that $a_2a_4, a_4b_1 \in E(G)$.

Proof of 2.13.3. If $\{a_4\}$ is anticomplete to A_2 , then from Lemma 2.1:(ii), $\{a_4\}$ is complete to B_1 , and so from Lemma 2.1:(v), $|B_1| \leq 1$. Also if $\{a_4\}$ is anticomplete to B_1 , then from Lemma 2.1:(ii), again we have $|B_1| \leq 1$. In both cases, $A_2 \cup B_1 \cup \{v_3\}$ induces a bipartite graph (by Lemma 2.1:(i)). Since $A_1 \cup T \cup \{v_2, v_4\}$ is a stable set (by Lemma 2.1:(i)), from 2.13.1, $\chi(G[V(G) \setminus D]) \leq 5$, and we are done. So there are vertices $a_2 \in A_2$ and $b_1 \in B_1$ such that $a_2a_4, a_4b_1 \in E(G)$. ■

Then, by 2.13.3, $B_1 \setminus \{b_1\}$ is a stable set (by Lemma 2.1:(ii)). Now, for any $d \in D$, since $\{a_4, b_1, v_1, v_4, d\}$ does not induce a $\overline{P_2 + P_3}$, $\{b_1\}$ is anticomplete to $D \setminus N(a_4)$, and $\{b_1\}$ is complete to $N(a_4) \cap D$. By Lemma 2.4:(iii), $D \setminus N(a_4)$ is complete to $\{a_2\}$, and hence by Lemma 2.1:(iii), $D \setminus N(a_4)$ and $N(a_4) \cap D$ are cliques. So since $N(a_4) \cap D$ is complete to $\{b_1, v_1, v_2\}$, $\chi(G[N(a_4) \cap D]) \leq \omega(G) - 3$. Also if there are vertices, say $d, d' \in D \setminus N(a_4)$, then $\{a_2, a_4, v_4, d, d'\}$ induces a $\overline{P_2 + P_3}$; so $|D \setminus N(a_4)| \leq 1$. Thus $(D \setminus N(a_4)) \cup \{b_1\}$ is a stable set. Since $A_1 \cup T \cup \{v_2, v_4\}$, $B_1 \setminus \{b_1\}$ and $A_2 \cup \{v_3\}$ are stable sets (by Lemma 2.1:(i)), from 2.13.1, $\chi(G[V(G) \setminus (N(a_4) \cap D)]) \leq 6$, and we conclude that $\chi(G) \leq 6 + (\omega(G) - 3) = \omega(G) + 3$. So G is a good graph. □

2.4.2 $(P_2 + P_3, \overline{P_2 + P_3}, K_{2,3}, \text{banner})$ -free graphs that contain an H_2

Theorem 2.14 If G is a $(P_2 + P_3, \overline{P_2 + P_3}, K_{2,3}, \text{banner})$ -free graph that contains an H_2 , then G is a good graph.

Proof. This follows from Theorem 2.15 given below. □

Theorem 2.15 If G is a $(P_2 + P_3, \overline{P_2 + P_3}, K_2 + K_3, \text{Co-banner})$ -free graph that contains an $\overline{H_2}$, then \overline{G} is a good graph.

Proof. Let G be a $(P_2 + P_3, \overline{P_2 + P_3}, K_2 + K_3, \text{Co-banner})$ -free graph that contains an $\overline{H_2}$. We may consider an $\overline{H_2}$ with vertices and edges as shown in Figure 9. Let $C := \{v_1, v_2, v_3, v_4\}$. We partition $V(G) \setminus C$ as in Section 2.2, and we use the lemmas in Section 2.2. Then clearly $b_1 \in B_1$ and $b_2 \in B_2$. So from Lemma 2.6:(ii), we have $|B_3| \leq 1$ and $|B_4| \leq 1$. Moreover, if there is a vertex, say $a_1 \in A_1$, then by Lemma 2.6:(i), $a_1b_1 \notin E(G)$, and by Lemma 2.6:(ii), $a_1b_2 \in E(G)$, and then $\{a_1, v_1, v_2, b_2, b_1\}$ induces a $\overline{P_2 + P_3}$; so $A_1 = \emptyset$. Likewise, $A_3 = \emptyset$. Hence $A = A_2 \cup A_4$. Next if there are vertices, say $x, x' \in X_2$, then $\{b_1, b_2, x, v_4, x'\}$ induces a $P_2 + P_3$ (by Lemma 2.2:(ii) and Lemma 2.3:(i)); so $|X_2| \leq 1$. Moreover, we have the following claim:

2.15.1 $\theta(G[C \cup A \cup X_1 \cup T]) \leq \alpha(G)$.

Proof of 2.15.1. If there are adjacent vertices, say $a \in A_2$ and $a' \in A_4$, then $\{a, a', b_1, v_2, b_2\}$ induces a $\overline{P_2 + P_3}$ (by Lemma 2.6:(i) and Lemma 2.6:(ii)); so A_2 is anticomplete to A_4 . Hence $A_2 \cup A_4 \cup T \cup \{v_1, v_3\}$ is a stable set (by Lemma 2.1:(i)). Moreover, $X_1 \cup \{v_2, v_4\}$ is also a stable set (by Lemma 2.2:(ii)). So $G[C \cup A \cup X_1 \cup T]$ is a bipartite graph, and hence $\theta(G[C \cup A \cup X_1 \cup T]) \leq \alpha(G)$. This proves 2.15.1. ■

We may suppose that \overline{G} does not have twins or a universal vertex. So, to prove the theorem, it is enough to show that either v_2 is a nice vertex in \overline{G} or $\theta(G[B \cup D \cup X_2]) \leq 3$ (by 2.15.1). Note that $|\overline{N}_G(v_2)| = |\{v_4\} \cup A_4 \cup T \cup X_1| + |B_3| + |B_4| \leq |\{v_4\} \cup A_4 \cup T \cup X_1| + 2$. If $|X_1| \leq 1$, then since $\{v_1, v_3\} \cup A_4 \cup T$ is a stable set (by Lemma 2.1:(i)), we see that $|\overline{N}_G(v_2)| \leq (\alpha(G) - 2) + 4 = \alpha(G) + 2$, and hence v_2 is a nice vertex in \overline{G} . So $|X_1| \geq 2$, and say $x_1, x'_1 \in X_1$. We consider two cases based on the set A_4 .

Case 1 *Suppose that the set A_4 is non-empty.*

Say $a_4 \in A_4$. Then by Lemma 2.6:(ii), $|B_1| = 1$ and $|B_2| = 1$, and so $B_1 = \{b_1\}$ and $B_2 = \{b_2\}$. Next we claim that:

2.15.2 D is a clique.

Proof of 2.15.2. Suppose to the contrary that there exist non-adjacent vertices in D , say d_1 and d_2 . Then by Lemma 2.1:(iii), we may suppose that $a_4 d_1 \notin E(G)$. If there is a vertex, say $x \in X_1$ such that $a_4 x \in E(G)$, then $\{a_4, v_4, v_1, x, d_1\}$ induces a $\overline{P_2 + P_3}$ (by Lemma 2.3:(iii)); so $\{a_4\}$ is anticomplete to X_1 . Then $\{a_4, b_1, x_1, v_3, x'_1\}$ induces a $P_2 + P_3$ (by Lemma 2.6:(ii) and Lemma 2.3:(i)), a contradiction. So 2.15.2 holds. ■

Now since $|X_2| \leq 1$, from Lemma 2.3:(iii) and 2.15.2, $D \cup X_2$ is a clique. Also since $|B_i| \leq 1$, for each i , by Lemma 2.6:(ii), $B_3 \cup \{b_1\}$ and $B_4 \cup \{b_2\}$ are cliques. So $\theta(G[B \cup D \cup X_2]) \leq 3$, and we are done.

Case 2 *Suppose that the set A_4 is empty.*

If T is empty, then by Lemma 2.2:(ii), we have $|\overline{N}_G(v_2)| \leq \alpha(G) + 2$, and hence v_2 is a nice vertex in \overline{G} . So suppose that T is non-empty, and say $t \in T$. Then:

2.15.3 $\{t\}$ is complete to B .

Proof of 2.15.3. Suppose to the contrary that there is a vertex, say $b \in B$ such that $bt \notin E(G)$. We may assume that $b \in B_1$. Recall that, by Lemma 2.3:(i), B is anticomplete to X . Now, for any $x' \in X_1$, since $\{b, v_1, v_2, t, x'\}$ does not induce a Co-banner, $\{t\}$ is anticomplete to X_1 . Likewise, $\{t\}$ is anticomplete to X_2 . Next if t has a neighbor in some B_i , say b' , then $\{b', t, v_{i+2}, v_{i+3}, x_1\}$ induces a $P_2 + P_3$; so $\{t\}$ is anticomplete to B . Since $\{t\}$ is anticomplete to $C \cup A \cup B \cup X$, and since \overline{G}

does not have a universal vertex, t must have a neighbor in D , say d . Then by Lemma 2.1:(iii), $N_G(t)$ is a clique. Thus $\overline{N}_G(d) \subseteq V(G) \setminus (N_G(t) \cup \{t\}) = \overline{N}_G(t)$; and so $N_{\overline{G}}(d) \subseteq N_{\overline{G}}(t)$. Hence, d and t are twins in \overline{G} which is a contradiction. This proves 2.15.3. ■

2.15.4 $B_1 = \{b_1\}$, $B_2 = \{b_2\}$, and B is complete to D .

Proof of 2.15.4. By 2.15.3 and Lemma 2.5:(ii), we have $B_1 = \{b_1\}$. Likewise, $B_2 = \{b_2\}$. Next if there are non-adjacent vertices, say $b \in B_i$ and $d \in D$, then by Lemma 2.1:(iii), $bd \notin E(G)$, and then $\{b, t, d, v_{i+2}, v_{i+3}\}$ induces a $K_2 + K_3$, by 2.15.3. So B is complete to D . This proves 2.15.4. ■

Now since $|B_3| \leq 1$, $|B_4| \leq 1$ and $|X_2| \leq 1$, from 2.15.4, Lemma 2.1:(iii) and Lemma 2.6:(ii), clearly $B_1 \cup B_3 \cup D$, $B_2 \cup B_4$ and X_2 are cliques. So $\theta(G[B \cup D \cup X_2]) \leq 3$. □

2.4.3 $(P_2 + P_3, \overline{P_2 + P_3}, K_{2,3}, \text{banner}, H_2)$ -free graphs that contain an H_3

We start with the following. Let G be a $(P_2 + P_3, \overline{P_2 + P_3}, K_2 + K_3, \text{Co-banner}, \overline{H_2})$ -free graph contains an $\overline{H_3}$ such that \overline{G} does not have twins or a universal vertex. Let us assume that G contains an $\overline{H_3}$ with vertices and edges as shown in Figure 9. Let $C := \{v_1, v_2, v_3, v_4\}$. We partition $V(G) \setminus C$ as in Section 2.2, and we use the lemmas in Section 2.2. Clearly $b^* \in B_1$ and $t^* \in T$. Also since $b^*t^* \in E(G)$, B is not anticomplete to T . Moreover, the graph G has some more properties, and they are given in Lemmas 2.16 to 2.24 below.

Lemma 2.16 *The following hold:*

- (i) For $i \in \{1, 2, 3, 4\}$, $B_i \cup B_{i+1}$ is a stable set.
- (ii) B is complete to T .
- (iii) For $i \in \{1, 2, 3, 4\}$, $|B_i| \leq 1$, and $|T| = 1$.
- (iv) B is complete to D . Moreover, D is a clique.
- (v) $\theta(G[B \cup D \cup T]) \leq 2$ and $\theta(G[B \cup C \cup D \cup T]) \leq 3$.

Proof. (i): By Lemma 2.6:(i), it is enough to show that B_i is anticomplete to B_{i+1} . Now if there are adjacent vertices, say $b \in B_i$ and $b' \in B_{i+1}$, then $C \cup \{b, b'\}$ induces an $\overline{H_2}$. So B_i is anticomplete to B_{i+1} . ■

(ii): Suppose to the contrary that there exist non-adjacent vertices, say $b \in B$ and $t \in T$. We may assume that $b \in B_1$. Now, if t has a neighbor in X , say x , then $\{t, x, v_1, v_2, b\}$ induces a Co-banner (by Lemma 2.3:(i)), and if t has a neighbor in $B_2 \cup B_4$, say $b' \in B_2$, then from Lemma 2.16:(i), $bb' \notin E(G)$, and then $\{b', t, b, v_1, v_4\}$ induces a $P_2 + P_3$. These contradictions together with Lemma 2.1:(i) show that $\{t\}$ is anticomplete to $C \cup A \cup B_2 \cup B_4 \cup X$. Since \overline{G} has no universal vertices, t must have a neighbor in $B_1 \cup B_3 \cup D$, say p . By Lemma 2.1:(iii) and Lemma 2.6:(ii), $N_G(t)$ is a clique. Thus $\overline{N}_G(p) \subseteq V(G) \setminus (N_G(t) \cup \{t\}) = \overline{N}_G(t)$, and so $N_{\overline{G}}(p) \subseteq N_{\overline{G}}(t)$. Hence, p and t are twins in \overline{G} which is a contradiction. So Lemma 2.16:(ii) holds. ■

(iii): By Lemma 2.5:(ii) and Lemma 2.16:(ii), clearly $|B_i| \leq 1$. Next if there are vertices, say $t, t' \in T$, then from Lemma 2.16:(ii) and Lemma 2.1:(i), $\{v_3, v_4, t, b^*, t'\}$ induces a $P_2 + P_3$; so $|T| \leq 1$. Since $T \neq \emptyset$, we have $|T| = 1$. This proves Lemma 2.16:(iii). ■

(iv): If there are non-adjacent vertices, say $b \in B_i$ and $d \in D$, then $\{b, t^*, d, v_{i+2}, v_{i+3}\}$ induces a $K_2 + K_3$ (by Lemma 2.1:(iii), Lemma 2.16:(ii) and Lemma 2.16:(iii)), a contradiction. So B is complete to D . This proves the first assertion of Lemma 2.16:(iv). Since $B \neq \emptyset$, the second assertion follows from the first assertion and from Lemma 2.1:(iii). So Lemma 2.16:(iv) holds. ■

(v): We use Lemma 2.6:(ii), Lemma 2.16:(iii), and Lemma 2.16:(iv). Since $B_1 \cup B_3 \cup T$ and $B_2 \cup B_4 \cup D$ are cliques, clearly $\theta(G[B \cup D \cup T]) \leq 2$. Also since $B_1 \cup B_3 \cup T$, $B_2 \cup D \cup \{v_2, v_3\}$ and $B_4 \cup \{v_1, v_4\}$ are cliques, we have $\theta(G[B \cup C \cup D \cup T]) \leq 3$. This proves Lemma 2.16:(v). □

Lemma 2.17 *The following hold:*

(i) X is complete to T .

(ii) Let $j, k \in \{1, 2\}$ and $j \neq k$. Then for any $a \in A_j \cup A_{j+2}$, we have $|X_k \setminus N_G(a)| \leq 1$, and for any $x \in X_k$, we have $|A_j \setminus N_G(x)| \leq 1$ and $|A_{j+2} \setminus N_G(x)| \leq 1$.

Proof. (i): If there are non-adjacent vertices, say $x \in X$ and $t \in T$, then for any $b \in B$, say $b \in B_i$, from Lemma 2.16:(ii) and Lemma 2.3:(i), $\{b, t, x, v_{i+2}, v_{i+3}\}$ induces a $P_2 + P_3$. So Lemma 2.17:(i) holds. ■

(ii): We prove for $j = 1$. By symmetry, we may suppose that $a \in A_1$. If there are vertices, say $x_2, x'_2 \in X_2 \setminus N_G(a)$, then from Lemma 2.1:(i), Lemma 2.2:(ii) and Lemma 2.17:(i), $\{a, v_1, x_2, t^*, x'_2\}$ induces a $P_2 + P_3$; so $|X_2 \setminus N_G(a)| \leq 1$. Next if there are vertices, say $a_1, a'_1 \in A_1 \setminus N(x)$, then again from Lemma 2.1:(i) and Lemma 2.17:(i), $\{t^*, x, a_1, v_1, a'_1\}$ induces a $P_2 + P_3$; so $|A_1 \setminus N_G(x)| \leq 1$. Likewise, $|A_3 \setminus N_G(x)| \leq 1$. This proves Lemma 2.17:(ii). □

Lemma 2.18 *If one of A_i, A_{i+2} is empty, for each $i \in \{1, 2, 3, 4\}$, then \overline{G} is a good graph.*

Proof. We may assume that $A_3 \cup A_4 = \emptyset$. Also:

2.18.1 *We may assume that $A_1 \cup X_1$ and $A_2 \cup X_2$ are not stable sets.*

Proof of 2.18.1. If $A_1 \cup X_1$ is a stable set, then since $A_1 \cup B_4 \cup X_1$ is a stable set (by Lemma 2.6:(i) and Lemma 2.3:(i)), from Lemma 2.16:(iii), $|\overline{N}_G(v_2)| = |A_1 \cup B_4 \cup X_1| + |B_3| + |T| + |\{v_4\}| \leq (\alpha(G) - 1) + 3 = \alpha(G) + 2$; so v_2 is a nice vertex in \overline{G} , and we are done. Hence we may assume that $A_1 \cup X_1$ is not a stable set. Likewise, we may assume that $A_2 \cup X_2$ is not a stable set. ■

2.18.2 *We may assume that $|A_1| \geq 2$ and $|A_2| \geq 2$.*

Proof of 2.18.2. If $|A_1| \leq 1$, then since $B_3 \cup B_4 \cup X_1$ is a stable set (by Lemma 2.3:(i), Lemma 2.16:(i)), from Lemma 2.16:(iii), $|\overline{N}_G(v_2)| = |B_3 \cup B_4 \cup X_1| + |A_1| + |T| + |\{v_4\}| \leq (\alpha(G) - 1) + 3 = \alpha(G) + 2$; so v_2 is a nice vertex in \overline{G} , and we are done. Hence we may assume that $|A_1| \geq 2$. Likewise, we may assume that $|A_2| \geq 2$. ■

2.18.3 We may assume that $|X_1| \geq 2$ and $|X_2| \geq 2$.

Proof of 2.18.3. If $|X_1| \leq 1$, then since $A_1 \cup T \cup \{v_4\}$ is a stable set (by Lemma 2.1:(i)), from Lemma 2.16:(iii), $|\overline{N}_G(v_2)| = |A_1 \cup T \cup \{v_4\}| + |B_3 \cup B_4| + |X_1| \leq (\alpha(G) - 1) + 3 = \alpha(G) + 2$; so again v_2 is a nice vertex in \overline{G} , and we are done. Hence we may assume that $|X_1| \geq 2$. Likewise, we may assume that $|X_2| \geq 2$. ■

By 2.18.1, there are adjacent vertices, say $a_1 \in A_1$ and $x_1 \in X_1$. Moreover, we claim the following:

2.18.4 $|A_1| \leq 3$, and $|A_2| \leq 3$.

Proof of 2.18.4. Suppose that $|A_1| \geq 4$. Then since $|X_2| \geq 2$, by Lemma 2.17:(ii), there is a vertex in X_2 , say x_2 , such that $a_1x_2 \in E(G)$. Again, by Lemma 2.17:(ii) and by the pigeonhole principle, there are vertices, say $a'_1, a''_1 \in A_1 \setminus \{a_1\}$, such that $a'_1x_2, a''_1x_2 \in E(G)$. Now, since $\{x_1, x_2, v_1, v_2, a_1\}$ does not induce a $\overline{P_2 + P_3}$, we have $x_1x_2 \notin E(G)$. Then since $\{a'_1, x_1, a_1, x_2, v_1\}$ does not induce a $\overline{P_2 + P_3}$, $a'_1x_1 \notin E(G)$. Likewise $a''_1x_1 \notin E(G)$. But now $\{v_3, x_1, a'_1, x_2, a''_1\}$ induces a $P_2 + P_3$. So $|A_1| \leq 3$. Likewise, $|A_2| \leq 3$. This proves 2.18.4. ■

2.18.5 $|X_1| \leq 3$, and $|X_2| \leq 3$.

Proof of 2.18.5. Suppose that $|X_2| \geq 4$. Then since $|A_1| \geq 2$ (by 2.18.2), let $a'_1 \in A_1 \setminus \{a_1\}$. Then by Lemma 2.17:(ii) and by the pigeonhole principle, there are vertices, say $x, x' \in X_2$ such that $\{a_1, a'_1\}$ is complete to $\{x, x'\}$. Also since $\{a_1, x, a'_1, x_1, v_1\}$ does not induce a $\overline{P_2 + P_3}$ (by Lemma 2.1:(i)), we have $a'_1x_1 \notin E(G)$. If $xx_1 \in E(G)$, then $\{a_1, v_1, v_2, x, x_1\}$ induces a $\overline{P_2 + P_3}$; so we have $xx_1 \notin E(G)$. Likewise, $x'x_1 \notin E(G)$. Then $\{v_3, x_1, x, a'_1, x'\}$ induces a $P_2 + P_3$. So $|X_2| \leq 3$. Likewise, $|X_1| \leq 3$. This proves 2.18.5. ■

2.18.6 $\theta(G[A_1 \cup X_2]) \leq 3$ and $\theta(G[A_2 \cup X_1]) \leq 3$.

Proof of 2.18.6. The proof follows from Lemma 2.1:(i), Lemma 2.2:(ii) and Lemma 2.17:(ii), and from 2.18.4 and 2.18.5. ■

Now from 2.18.6 and Lemma 2.16:(v), we conclude that $\theta(G) \leq 9$. Also from 2.18.2 and Lemma 2.1:(i), since $A_1 \cup T \cup \{v_2, v_4\}$ is a stable set, we have $\alpha(G) \geq 5$. If $\alpha(G) \geq 6$, then $\theta(G) \leq \alpha(G) + 3$, and we are done. So we may conclude that $\alpha(G) = 5$. Since $A_1 \cup T \cup \{v_2, v_4\}$ is a stable set (by Lemma 2.1:(i)), from 2.18.2, $|A_1| = 2$. Likewise, $|A_2| = 2$. Now, if $|X_1| = 2$, then by Lemma 2.17:(ii), $\theta(G[A_2 \cup X_1]) \leq 2$, and so by 2.18.6 and Lemma 2.16:(v), $\theta(G) \leq 8 = \alpha(G) + 3$. So we may suppose that $|X_1| = 3$ and $|X_2| = 3$. Since $X_1 \cup B_1 \cup B_2 \cup \{v_4\}$ is a stable set and since $B_1 \neq \emptyset$, clearly $B_2 = \emptyset$. Then as in 2.18.6, we have $\theta(G[A_2 \cup (X_1 \setminus \{x_1\})]) \leq 2$, and $\theta(G[A_1 \cup X_2 \cup \{v_2\}]) \leq 3$. Also $D \cup \{v_3, x_1\}$ is a clique (by Lemma 2.16:(iv) and Lemma 2.3:(iii)), $B_4 \cup \{v_1, v_4\}$ is a clique (by Lemma 2.16:(iii)), and $B_1 \cup B_3 \cup T$ is a clique (by Lemma 2.6:(ii), Lemma 2.16:(ii) and Lemma 2.16:(iii)). So we conclude that $\theta(G) \leq 8 = \alpha(G) + 3$. This proves Lemma 2.18. □

Lemma 2.19 *If A_i is anticomplete to A_{i+2} , for each $i \in \{1, 2, 3, 4\}$, then \overline{G} is a good graph.*

Proof. First we observe the following:

2.19.1 *If there are vertices, say $p \in A_i$, $q \in A_{i+1}$, and $r \in A_{i+2}$, then $pq, qr \in E(G)$ or $pq, qr \notin E(G)$.*

Proof of 2.19.1. If $pq \in E(G)$ and $qr \notin E(G)$ (say), then $\{r, v_{i+2}, v_i, p, q\}$ induces a $P_2 + P_3$. So 2.19.1 holds. ■

By Lemma 2.18, we may suppose that $A_1, A_3 \neq \emptyset$. Then by Lemma 2.1:(ii), we let $A_1 := \{a_1\}$ and $A_3 := \{a_3\}$. First suppose that $\{a_1\}$ is complete to $A_2 \cup A_4$. Then by Lemma 2.5:(ii), we have $|A_2| \leq 1$ and $|A_4| \leq 1$. Also $\{a_3\}$ is complete to A_4 (by 2.19.1). So by Lemma 2.6:(ii), Lemma 2.16:(ii) and Lemma 2.16:(iii), $A_2 \cup B_3 \cup \{a_1\}$, $A_4 \cup B_1 \cup \{a_3\}$, and $B_2 \cup B_4 \cup T$ are cliques. Also from Lemma 2.2:(ii), Lemma 2.3:(iii) and Lemma 2.16:(iv), it follows that $G[X_1 \cup X_2 \cup C \cup D]$ is a perfect graph, as it is the join of a bipartite graph and a complete graph. Thus $\theta(G) \leq \alpha(G) + 3$, and we are done. So we may conclude that $\{a_1\}$ is not complete to $A_2 \cup A_4$, and let $a_2 \in A_2$ be such that $a_1 a_2 \notin E(G)$. So $\{a_1, a_2, a_3\}$ is a stable set (by 2.19.1). We consider two cases based on the set A_4 .

Case 1 *The set A_4 is non-empty.*

By Lemma 2.1:(ii), $A_2 \setminus \{a_2\} = \emptyset$ and $|A_4| = 1$. Let $A_4 := \{a_4\}$. So $A = \{a_1, a_2, a_3, a_4\}$ is a stable set (by 2.19.1). Next we claim that:

2.19.2 $|X_1| \leq 3$ and $|X_2| \leq 3$. Hence $\theta(G[X_2 \cup \{a_1, a_3\}]) \leq 3$ and $\theta(G[X_1 \cup \{a_2, a_4\}]) \leq 3$.

Proof of 2.19.2. Suppose that $|X_1| \geq 4$. Then by Lemma 2.17:(ii), there are vertices $p, q, r \in X_1$ such that $\{a_2\}$ is complete to $\{p, q, r\}$. By Lemma 2.2:(iii), we may suppose that $pa_3, qa_3 \notin E(G)$. But then from Lemma 2.2:(ii), Lemma 2.3:(i), Lemma 2.6:(i) and Lemma 2.6:(ii), $\{b^*, a_3, a_2, p, q\}$ induces $P_2 + P_3$; so $|X_1| \leq 3$. Likewise, $|X_2| \leq 3$. This proves the first assertion of 2.19.2. The second assertion follows from the first assertion and from Lemma 2.17:(ii). ■

By Lemma 2.16:(v) and 2.19.2, we have $\theta(G) \leq 9$. If $\alpha(G) \geq 6$, then $\theta(G) \leq \alpha(G) + 3$. So we may suppose that $\alpha(G) \leq 5$. Since $T \cup \{a_1, a_3, v_2, v_4\}$ is a stable set of size 5 (by Lemma 2.1:(i)), $\alpha(G) = 5$. Then we claim that:

2.19.3 $\theta(G[X_1 \cup \{a_1, a_3, v_1, v_3\}]) \leq 3$. Likewise, $\theta(G[X_2 \cup \{a_2, a_4, v_2, v_4\}]) \leq 3$.

Proof of 2.19.3. Since $X_1 \cup \{v_2, v_4\}$ is a stable set (by Lemma 2.2:(ii)), and since $\alpha(G) = 5$, clearly $|X_1| \leq 3$. If $|X_1| \leq 1$, then since $\{a_1, v_1\}$, $\{a_3, v_3\}$ and X_1 are cliques, $\theta(G[X_1 \cup \{a_1, a_3, v_1, v_3\}]) \leq 3$; so we may suppose that $|X_1| \geq 2$. Say $x_1, x'_1 \in X_1$. Since $\{a_1, a_3, v_2, v_4, x_1, x'_1\}$ is a stable set of size 6, we may suppose that $a_1 x_1 \in E(G)$. Then since $\{a_1, v_1, x_1, v_3, a_3\}$ does not induce a Co-banner, $a_3 x_1 \in E(G)$. So by Lemma 2.2:(iii), $\{a_1, a_3\}$ is anticomplete to $X_1 \setminus \{x_1\}$. Since

$(X_1 \setminus \{x_1\}) \cup \{a_1, a_3, v_2, v_4\}$ is a stable set of size at most 5, $|X_1 \setminus \{x_1\}| = 1$, and so $X_1 \setminus \{x_1\} = \{x'_1\}$. Then since $\{a_1, v_1, x_1\}$, $\{a_3, v_3\}$ and $\{x'_1\}$ are cliques, $\theta(G[X_1 \cup \{a_1, a_3, v_1, v_3\}]) \leq 3$. This proves 2.19.3. ■

So by 2.19.3 and Lemma 2.16:(v), we have $\theta(G) \leq 8 = \alpha(G) + 3$.

Case 2 *The set A_4 is empty.*

Let $A'_2 := \{a \in A_2 \mid aa_1 \in E(G)\}$; so $a_2 \in A_2 \setminus A'_2$. By Lemma 2.5:(ii), $|A'_2| \leq 1$. Next we claim the following:

2.19.4 *We may assume that $|X_1| \geq 2$.*

Proof of 2.19.4. If $|X_1| \leq 1$, then since $T \cup \{a_1, a_3, v_4\}$ is a stable set (by Lemma 2.1:(i)), by Lemma 2.16:(iii), $|\overline{N}_G(v_2)| = |X_1| + |T \cup \{a_1, a_3, v_4\}| + |B_3 \cup B_4| \leq \alpha(G) + 2$; so v_2 is a nice vertex in \overline{G} , and we are done. Hence we may assume that $|X_1| \geq 2$. ■

2.19.5 $|X_1 \cup \{a_1, a_3, v_4\}| \leq \alpha(G)$.

Proof of 2.19.5. If $X_1 \cup \{a_1, a_3, v_4\}$ is a stable set, then we are done. So we may assume that, by Lemma 2.2:(ii), there is a vertex, say $x \in X_1$ such that $a_1x \in E(G)$. Then since $\{a_1, a_3, v_1, x, v_3\}$ does not induce a Co-banner, $a_3x \in E(G)$. Also by Lemma 2.2:(iii), $\{a_1, a_3\}$ is anticomplete to $X_1 \setminus \{x\}$. So by Lemma 2.2:(ii), $(X_1 \setminus \{x\}) \cup \{a_1, a_3, v_4\}$ is a stable set, and since $\{v_2\}$ is anticomplete to $(X_1 \setminus \{x\}) \cup \{a_1, a_3, v_4\}$, we have $|(X_1 \setminus \{x\}) \cup \{a_1, a_3, v_4\}| \leq \alpha(G) - 1$, and hence $|X_1 \cup \{a_1, a_3, v_4\}| \leq \alpha(G)$. This proves 2.19.5. ■

2.19.6 *We may assume that both B_3 and B_4 are non-empty.*

Proof of 2.19.6. If one of B_3 and B_4 is empty, then by Lemma 2.16:(iii), $|B_3 \cup B_4| \leq 1$, and then by 2.19.5 and Lemma 2.16:(iii), $|\overline{N}_G(v_2)| = |X_1 \cup \{a_1, a_3, v_4\}| + |B_3 \cup B_4| + |T| \leq \alpha(G) + 2$; so v_2 is a nice vertex in \overline{G} , and we are done. So we may conclude that both B_3 and B_4 are non-empty. ■

2.19.7 $\theta(G[(A_2 \setminus A'_2) \cup X_1]) \leq \alpha(G) - 3$.

Proof of 2.19.7. First, since X is anticomplete to B (by Lemma 2.3:(i)), from Lemma 2.16:(i) and Lemma 2.2:(ii), $X_1 \cup B_3 \cup B_4 \cup \{v_2\}$ is a stable set, and so by 2.19.6, $|X_1| \leq \alpha(G) - 3$. Now, if $A_2 \setminus A'_2 = \{a_2\}$, then from 2.19.4 and Lemma 2.17:(ii), $\{a_2\}$ is not anticomplete to X_1 , and hence $\theta(G[(A_2 \setminus A'_2) \cup X_1]) \leq |X_1| \leq \alpha(G) - 3$. So we may suppose that $|A_2 \setminus A'_2| \geq 2$. For integers $r \geq 2$ and $k \geq 2$, let $X_1 := \{p_1, p_2, \dots, p_r\}$ and $A_2 \setminus A'_2 := \{q_1, q_2, \dots, q_k\}$. If $r \geq k$, then by Lemma 2.17:(ii), we may suppose that $p_jq_j \in E(G)$, where $j \in \{1, 2, \dots, k\}$, and then $\theta(G[(A_2 \setminus A'_2) \cup X_1]) \leq |X_1| \leq \alpha(G) - 3$; so suppose that $r < k$. Then again by Lemma 2.17:(ii), we may suppose that $p_jq_j \in E(G)$, where $j \in \{1, 2, \dots, r\}$, and hence $\theta(G[(A_2 \setminus A'_2) \cup X_1]) \leq k = |A_2 \setminus A'_2|$. Now since $\{a_3\}$ is anticomplete to $A_2 \setminus A'_2$ (by 2.19.1), $(A_2 \setminus A'_2) \cup \{a_1, a_3, v_4\}$ is a stable set, and so $|A_2 \setminus A'_2| \leq \alpha(G) - 3$. Thus we conclude that $\theta(G[(A_2 \setminus A'_2) \cup X_1]) \leq \alpha(G) - 3$. This proves 2.19.7. ■

2.19.8 $\theta(G[A'_2 \cup X_2 \cup \{a_1, a_3\}]) \leq 3$.

Proof of 2.19.8. To prove the claim, we further partition X_2 as follows:

$$\begin{aligned} X'_2 &:= \{x \in X_2 \mid xa_2 \in E(G)\}, \\ X''_2 &:= \{x \in X_2 \mid xa_1 \in E(G), xa_2 \notin E(G)\}, \text{ and} \\ X'''_2 &:= \{x \in X_2 \mid xa_1, xa_2 \notin E(G)\}. \end{aligned}$$

By Lemma 2.2:(iii), $|X'_2| \leq 1$, and by Lemma 2.17:(ii), $|X'''_2| \leq 1$. By Lemma 2.1:(iv), $A'_2 \cup X'''_2$ is a clique. Since for any $x \in X'_2$, $\{x, a_2, v_2, v_3, a_3\}$ does not induce a Co-banner, $X'_2 \cup \{a_3\}$ is a clique. Also if there are vertices, say $x, x' \in X''_2$, then for any $b \in B_4$, by Lemma 2.2:(ii), Lemma 2.3:(i), Lemma 2.6:(i) and Lemma 2.6:(ii), $\{a_2, b, x, a_1, x'\}$ induces a $P_2 + P_3$; so $|X''_2| \leq 1$, and hence $X''_2 \cup \{a_1\}$ is a clique. So we conclude that $\theta(G[A'_2 \cup X_2 \cup \{a_1, a_3\}]) \leq 3$. This proves 2.19.8. ■

Now, by 2.19.7 and 2.19.8, we have $\theta(G[A \cup X]) \leq \alpha(G)$, and so from Lemma 2.16:(v), we conclude that $\theta(G) \leq \alpha(G) + 3$. This proves Lemma 2.19. □

Lemma 2.20 *If $A_i \cup A_{i+2}$ induces a $K_{2,2}$, for some $i \in \{1, 2, 3, 4\}$, then \overline{G} is a good graph.*

Proof. We may assume that $i = 1$. By Lemma 2.1:(i), we may suppose that there are vertices, say $p_1, p_2 \in A_1$ and $q_1, q_2 \in A_3$ such that $\{p_1, p_2\}$ is complete to $\{q_1, q_2\}$. Then we claim the following.

2.20.1 $A_2 \cup A_4$ is an empty set.

Proof of 2.20.1. Suppose, up to symmetry, there is a vertex, say $a \in A_2$. By Lemma 2.5:(ii), we may suppose that $ap_1, aq_1 \notin E(G)$. Then since $\{a, v_2, p_1, q_1, p_2\}$ does not induce a $P_2 + P_3$, $ap_2 \in E(G)$. Likewise, $aq_2 \in E(G)$. But then $\{a, p_2, q_2, v_3, v_4\}$ induces a Co-banner. So $A_2 = \emptyset$. This proves 2.20.1. ■

2.20.2 X_2 is an empty set.

Proof of 2.20.2. Suppose there is a vertex, say $x \in X_2$. By Lemma 2.17:(ii), we may suppose that $xp_1, xq_1 \in E(G)$. Also by Lemma 2.4:(iii), we may suppose that $xp_2 \in E(G)$. Then $\{p_1, v_1, p_2, q_1, x\}$ induces a $\overline{P_2 + P_3}$. So $X_2 = \emptyset$. This proves 2.20.2. ■

Now, by 2.20.1 and 2.20.2, $|\overline{N}_G(v_1)| = |A_3 \cup T \cup B_2 \cup B_3 \cup \{v_3\}|$. Since $A_3 \cup T \cup \{v_2, v_4\}$ is a stable set (by Lemma 2.1:(i)), $|A_3 \cup T| \leq \alpha(G) - 2$. So by Lemma 2.16:(iii), $|\overline{N}_G(v_1)| = |A_3 \cup T| + |B_2 \cup B_3| + |\{v_3\}| \leq (\alpha(G) - 2) + 3 < \alpha(G) + 2$. This implies that v_1 is a nice vertex in \overline{G} , and hence \overline{G} is a good graph. This proves Lemma 2.20. □

Lemma 2.21 *If $A_i \cup A_{i+2}$ induces a $K_{1,3}$, for some $i \in \{1, 2, 3, 4\}$, then \overline{G} is a good graph.*

Proof. We may assume that $i = 1$. By Lemma 2.1:(i), we may suppose that there are vertices, say $p_1 \in A_1$ and $q_1, q_2, q_3 \in A_3$ such that $\{p_1\}$ is complete to $\{q_1, q_2, q_3\}$. By Lemma 2.20, we may suppose that $G[A_1 \cup A_3]$ is $K_{2,2}$ -free. Then we claim the following.

2.21.1 $A_1 \setminus \{p_1\}$ is an empty set.

Proof of 2.21.1. If there is a vertex, say $p_2 \in A_1 \setminus \{p_1\}$, then by Lemma 2.1:(ii), we may suppose that $p_2q_1, p_2q_2 \in E(G)$, and then $\{p_1, p_2, q_1, q_2\}$ induces a $K_{2,2}$ in $G[A_1 \cup A_3]$, a contradiction. So 2.21.1 holds. ■

2.21.2 $\{p_1\}$ is complete to A_2 . Likewise, $\{p_1\}$ is complete to A_4 .

Proof of 2.21.2. If there is a vertex, say $a \in A_2$ such that $ap_1 \notin E(G)$, then by Lemma 2.5:(ii), we may suppose that $aq_1, aq_2 \notin E(G)$, and then $\{a, v_2, q_1, p_1, q_2\}$ induces a $P_2 + P_3$. So 2.21.2 holds. ■

2.21.3 $|X_2| \leq 1$.

Proof of 2.21.3. If there are vertices, say $x_2, x'_2 \in X_2$, then by Lemma 2.17:(ii), we may suppose that $p_1x_2 \in E(G)$ and $q_1x_2, q_2x_2 \in E(G)$, and then $\{p_1, q_1, v_3, q_2, x_2\}$ induces a $\overline{P_2 + P_3}$. So 2.21.3 holds. ■

From 2.21.2 and Lemma 2.5:(ii), $|A_2| \leq 1$ and $|A_4| \leq 1$. So from 2.21.1, 2.21.2, Lemma 2.6:(ii) and Lemma 2.16:(iii), $A_1 \cup A_2 \cup B_3$ and $A_4 \cup B_1$ are cliques. Also from Lemma 2.16:(iii) and Lemma 2.16:(iv), $B_2 \cup D \cup \{v_2, v_3\}$ and $B_4 \cup \{v_1, v_4\}$ are cliques. So we conclude that $\theta(G - (A_3 \cup T \cup X_1)) \leq 5$, by 2.21.3. Moreover, by Lemma 2.1:(i) and Lemma 2.2:(ii), $A_3 \cup T \cup X_1$ induces a bipartite graph, and is anticomplete to $\{v_2, v_4\}$; so $\theta(G[A_3 \cup T \cup X_1]) \leq \alpha(G) - 2$. Hence $\theta(G) \leq \theta(G[A_3 \cup T \cup X_1]) + 5 \leq \alpha(G) + 3$. This proves Lemma 2.21. □

Lemma 2.22 For $i, j \in \{1, 2\}$ and $i \neq j$, if A_i is not anticomplete to A_{i+2} and $G[A_i \cup A_{i+2}]$ is $K_{1,3}$ -free, then $\theta(G[A_i \cup A_{i+2} \cup X_j]) \leq 3$.

Proof. We will show for $i = 1$. Suppose there are adjacent vertices, say $a_1 \in A_1$ and $a_3 \in A_3$. Now we partition $A_1 \setminus \{a_1\}$ and $A_3 \setminus \{a_3\}$ as follows:

$$\begin{aligned} A'_1 &:= \{a \in A_1 \setminus \{a_1\} \mid aa_3 \in E(G)\}, \\ A''_1 &:= \{a \in A_1 \setminus \{a_1\} \mid aa_3 \notin E(G)\}, \\ A'_3 &:= \{a \in A_3 \setminus \{a_3\} \mid aa_1 \in E(G)\}, \text{ and} \\ A''_3 &:= \{a \in A_3 \setminus \{a_3\} \mid aa_1 \notin E(G)\}. \end{aligned}$$

Since $G[A_i \cup A_{i+2}]$ is $K_{1,3}$ -free, $|A'_1| \leq 1$ and $|A'_3| \leq 1$. By Lemma 2.1:(ii), $|A''_1| \leq 1$ and $|A''_3| \leq 1$. By Lemma 2.1:(ii), $|A''_1| \leq 1$ and $|A''_3| \leq 1$. By Lemma 2.4:(iii), we partition X_2 as follows:

$$\begin{aligned} X'_2 &:= \{x \in X_2 \mid a_1x, a_3x \in E(G)\}, \\ X''_2 &:= \{x \in X_2 \mid a_1x \in E(G), a_3x \notin E(G)\}, \text{ and} \\ X'''_2 &:= \{x \in X_2 \mid a_3x \in E(G), a_1x \notin E(G)\}. \end{aligned}$$

Now if there are vertices, say $x, x' \in X'_2$, then $\{a_1, x, v_2, x', a_3\}$ induces a $\overline{P_2 + P_3}$ (by Lemma 2.2:(ii)); so $|X'_2| \leq 1$, and hence $X'_2 \cup \{a_1, a_3\}$ is a clique. Also by Lemma 2.17:(ii), $|X''_2| \leq 1$ and $|X'''_2| \leq 1$.

Moreover, for any $x \in X_2''$ and $a \in A_3''$, since $\{a, v_3, x, a_1, v_1\}$ does not induce a $P_2 + P_3$, A_3'' is complete to X_2'' . So by Lemma 2.1:(ii) and Lemma 2.4:(iii), $A_1' \cup A_3'' \cup X_2''$ is a clique. Likewise, $A_1'' \cup A_3' \cup X_2'''$ is also a clique. Hence $\theta(G[A_1 \cup A_3 \cup X_2]) \leq 3$. This proves Lemma 2.22. \square

Lemma 2.23 *If $\alpha(G) \leq 5$ and for each $i \in \{1, 2, 3, 4\}$, $G[A_i \cup A_{i+2}]$ is $K_{2,2}$ -free, then $\theta(G) \leq 8$.*

Proof. For each $i \in \{1, 2\}$, since $X_i \cup \{v_{i+1}, v_{i-1}\}$ is a stable set (by Lemma 2.2:(ii)), we have $|X_i| \leq 3$. Also for each $i \in \{1, 2, 3, 4\}$, since $A_i \cup \{v_{i+1}, v_{i-1}, t^*\}$ is a stable set (by Lemma 2.1:(i)) we have $|A_i| \leq 2$. Now for each $j \in \{1, 2\}$, if $\theta(G[A_j \cup A_{j+2} \cup X_j \cup \{v_j, v_{j+2}\}]) \leq 3$, then by Lemma 2.16:(v), we have $\theta(G) \leq 8$. So we assume that $\theta(G[A_1 \cup A_3 \cup X_1 \cup \{v_1, v_3\}]) \geq 4$. Also:

2.23.1 *We may assume that X_1 and X_2 are non-empty.*

Proof of 2.23.1. Since $|A_2| \leq 2$ and $|A_4| \leq 2$, we have $\theta(G[A_2 \cup A_4]) \leq 2$ (by Lemma 2.1:(ii)). Then by Lemma 2.16:(v) and Lemma 2.22, $\theta(G) \leq \theta(G[A_2 \cup A_4]) + \theta(G[A_1 \cup A_3 \cup X_2]) + \theta(G[B \cup C \cup X_2]) \leq 2 + 3 + 3 = 8$. Hence we may assume that $X_1 \neq \emptyset$. Likewise, we may assume $X_2 \neq \emptyset$. \blacksquare

By 2.23.1, let $x_1 \in X_1$ and $x_2 \in X_2$. Now we will show that $\theta(G[A_2 \cup A_4 \cup X_1]) \leq 2$ using a sequence of claims given below.

2.23.2 *A_1 and A_3 are non-empty.*

Proof of 2.23.2. Suppose not. Since $|X_1| \leq 3$, we may suppose $A_1 \neq \emptyset$ and $A_3 = \emptyset$. Let $a \in A_1$. Since $\theta(G[A_1 \cup A_3 \cup X_1 \cup \{v_1, v_3\}]) \geq 4$, we have $|X_1| \geq 2$. Let $x \in X_1 \setminus \{x_1\}$. First suppose that $|X_1| = 3$. Let $x' \in X_1 \setminus \{x_1, x\}$. Then since $X_1 \cup (A_1 \setminus \{a\}) \cup \{a, v_2, v_4\}$ is not a stable set of size 6 (by Lemma 2.1:(i) and Lemma 2.2:(ii)), we may suppose that $ax_1 \in E(G)$ and $A_1 \setminus \{a\}$ is complete to $\{x\}$ (by Lemma 2.2:(iii)). Hence $\theta(G[A_1 \cup X_1 \cup \{v_1, v_3\}]) \leq \theta(G[\{a, x_1, v_1\}]) + \theta(G[\{x, v_3\}]) + \theta(G[(A_1 \setminus \{a\}) \cup \{x\}]) = 3$, a contradiction to our assumption that $\theta(G[A_1 \cup A_3 \cup X_1 \cup \{v_1, v_3\}]) \geq 4$. So we assume that $|X_1| = 2$ and thus $|A_1| = 2$. Let $a' \in A_1 \setminus \{a\}$. Now since $\{a', a, x_1, x, v_2, v_4\}$ is not a stable set of size 6, we may suppose $ax_1 \in E(G)$. Since $\theta(G[(A_1 \setminus \{a\}) \cup (X_1 \setminus \{x\}) \cup \{v_1, v_3\}]) \leq 2$, we have $\theta(G[A_1 \cup X_1 \cup \{v_1, v_3\}]) \leq 3$, a contradiction to our assumption that $\theta(G[A_1 \cup A_3 \cup X_1 \cup \{v_1, v_3\}]) \geq 4$. So A_1 and A_3 are non-empty. This proves 2.23.2. \blacksquare

2.23.3 *Let $a \in A_1$ and $a' \in A_3$ be non-adjacent vertices. Then $N_G(a) \cap X_1 = N_G(a') \cap X_1$ and $|X_1| \leq 2$. Moreover, if $|X_2| = 2$, there is a vertex in X_1 which is complete to $\{a, a'\}$.*

Proof of 2.23.3. Since for any $x \in N_G(a) \cap X_1$, $\{a, v_1, x, v_3, a'\}$ does not induce a Co-banner, we have $x \in N_G(a') \cap X_1$; so $N_G(a) \cap X_1 \subseteq N_G(a') \cap X_1$. Also since for any $x' \in N_G(a') \cap X_1$, $\{a', v_3, x', v_1, a\}$ does not induce a Co-banner, we have $x' \in N_G(a) \cap X_1$; so $N_G(a') \cap X_1 \subseteq N_G(a) \cap X_1$. Hence $N_G(a) \cap X_1 = N_G(a') \cap X_1$. Now if $|X_1| = 3$, then $G[X_1 \cup \{a, a', v_2, v_3\}]$ has a stable set of size 6 (by Lemma 2.1:(i), Lemma 2.2:(ii) and Lemma 2.2:(iii)), a contradiction. So $|X_1| \leq 2$. This proves the first assertion of 2.23.3. Since $X_1 \cup \{a, a', v_2, v_3\}$ is not a stable set of size 6, there is a vertex in X_1 which is complete to $\{a, a'\}$. This proves 2.23.3. \blacksquare

2.23.4 $G[A_1 \cup A_3]$ is P_3 -free.

Proof of 2.23.4. Suppose not. Let $p, q, r \in A_1 \cup A_3$ be such that $pq, qr \in E(G)$ and $pr \notin E(G)$. By Lemma 2.1:(i), we may suppose that $p, r \in A_1$ and $q \in A_3$. Since for any $x \in X_1$, $\{p, q, r, x, t^*\}$ does not induce a $P_2 + P_3$, every vertex of X_1 has a neighbor in $\{p, q, r\}$. Thus by Lemma 2.2:(iii), $\theta(G[X_1 \cup \{p, q, r, v_1, v_3\}]) \leq 3$. So we assume that $A_3 \setminus \{q\} \neq \emptyset$. Let $s \in A_3 \setminus \{q\}$. So $A_3 = \{q, s\}$. Since $G[A_1 \cup A_3]$ is $K_{2,2}$ -free, we may suppose that $rs \in E(G)$ and $ps \notin E(G)$ (by Lemma 2.1:(ii)). So $|X_1| \leq 2$ (by 2.23.3). Suppose p has a neighbor in X_1 , say x' . Then by 2.23.3, $sx' \in E(G)$. Also $X_1 \setminus \{x'\}$ is either complete to $\{q\}$ or $\{r\}$ (by Lemma 2.2:(iii)). If $X_1 \setminus \{x'\}$ is complete to $\{q\}$, then $\{p, x', v_1\}$, $(X_1 \setminus \{x'\}) \cup \{q, v_3\}$ and $\{r, s\}$ are three cliques, otherwise $\{s, x', v_3\}$, $(X_1 \setminus \{x'\}) \cup \{r, v_1\}$ and $\{p, q\}$ are three cliques; so $\theta(G[A_1 \cup A_3 \cup X_1 \cup \{v_1, v_3\}]) \leq 3$, a contradiction to our assumption that $\theta(G[A_1 \cup A_3 \cup X_1 \cup \{v_1, v_3\}]) \geq 4$. So we assume that $\{p\}$ is anticomplete to X_1 . So by 2.23.3, $X_1 = \{x_1\}$ and $\{s\}$ is anticomplete to X_1 . Now if $qx_1 \in E(G)$, then $\{p, v_1\}$, $\{q, v_3, x_1\}$ and $\{r, s\}$ are three cliques, otherwise $\{p, q\}$, $\{r, v_1, x_1\}$ and $\{s, v_3\}$ are three cliques, a contradiction to our assumption that $\theta(G[A_1 \cup A_3 \cup X_1 \cup \{v_1, v_3\}]) \geq 4$. So $G[A_1 \cup A_3]$ is P_3 -free. This proves 2.23.4. ■

2.23.5 $G[A_1 \cup A_3]$ induces a $2P_2$.

Proof of 2.23.5. Suppose not. Then by 2.23.2 and 2.23.4, Lemma 2.1:(i) and Lemma 2.1:(ii), we may suppose that $G[A_1 \cup A_3]$ is isomorphic to one of $2K_1$, P_2 and $K_1 + K_2$. Suppose that A_1 is not complete to A_3 . Let $p \in A_1$ and $q \in A_3$ be non-adjacent vertices. We may assume that $A_1 \setminus \{p\} = \emptyset$. Since $A_3 \setminus \{q\}$ is complete to $\{p\}$ (by Lemma 2.1:(ii)), we may suppose that $|X_1| = 2$ (by 2.23.3). Let $x' \in X_1 \setminus \{x_1\}$. By 2.23.3, we may suppose that $px', qx' \in E(G)$. Now $\{q, x', v_3\}$, $\{x_1, v_1\}$ and $(A_3 \setminus \{q\}) \cup \{p\}$ are three cliques, a contradiction to our assumption that $\theta(G[A_1 \cup A_3 \cup X_1 \cup \{v_1, v_3\}]) \geq 4$. So we assume that A_1 is complete to A_3 . Hence $G[A_1 \cup A_3]$ is isomorphic to P_2 . So $|X_1| = 3$. Since $\theta(G[A_1 \cup A_3 \cup X_1 \cup \{v_2, v_4\}]) \geq 4$, either A_1 is anticomplete to X_1 or A_3 is anticomplete to X_1 . We may assume A_1 is anticomplete to X_1 . Then $A_1 \cup X_1 \cup \{v_2, v_4\}$ is a stable set of size 6 (by Lemma 2.1:(i) and Lemma 2.2:(ii)), a contradiction. This proves 2.23.5. ■

So by 2.23.5, we may suppose that there are vertices, say $p_1, p_2 \in A_1$ and $q_1, q_2 \in A_3$ such that $p_1q_1, p_2q_2 \in E(G)$ and $p_1q_2, p_2q_1 \notin E(G)$. Next we claim the following:

2.23.6 $|X_1| = 1$. Moreover, X_1 is anticomplete to $A_1 \cup A_3$.

Proof of 2.23.6. First we will show that $|X_1| = 1$. Suppose not, by 2.23.3, we may suppose that $\{x\} = X_1 \setminus \{x_1\}$. Then by 2.23.3, we may suppose that $p_1x_1 \in E(G)$. Since $\{b^*, v_2, p_1, x_1, p_2\}$ does not induce a $P_2 + P_3$ (by Lemma 2.1:(i), Lemma 2.3:(i) and Lemma 2.6:(i)), we have $p_2x_1 \notin E(G)$. Then by 2.23.3, we have $p_2x, q_1x \in E(G)$. Then $A_1 \cup A_3 \cup X_1 \cup \{v_1, v_3\}$ can be partitioned into three cliques, namely $\{p_1, x_1, v_1\}$, $\{q_1, x, v_3\}$ and $\{p_2, q_2\}$, a contradiction to our assumption that $\theta(G[A_1 \cup A_3 \cup X_1 \cup \{v_1, v_3\}]) \geq 4$. So $|X_1| = 1$. This proves the first assertion of 2.23.6. Now if

X_1 is not anticomplete to $A_1 \cup A_3$, then we may suppose that $p_1x_1 \in E(G)$ and as in the first assertion we partition $A_1 \cup A_3 \cup X_1 \cup \{v_1, v_3\}$ into three cliques, a contradiction to our assumption that $\theta(G[A_1 \cup A_3 \cup X_1 \cup \{v_1, v_3\}]) \geq 4$. This proves 2.23.6. ■

Now if $A_2 \cup A_4$ is complete to X_1 , then $\theta(G[A_2 \cup A_4 \cup X_1]) \leq 2$ (by Lemma 2.1:(ii) and 2.23.6). So we assume that there is a vertex in A_2 , say a_2 such that $a_2x_1 \notin E(G)$. Then $a_2p_1, a_2p_2, a_2q_1, a_2q_2 \notin E(G)$ (by Lemma 2.1:(iv) and 2.23.6). Next we claim the following:

2.23.7 $A_2 \setminus \{a_2\}$ is an empty set. Moreover, $\{a_2\}$ is complete to A_4 .

Proof of 2.23.7. First we will show that $A_2 \setminus \{a_2\} = \emptyset$. Suppose to the contrary there is a vertex in $A_2 \setminus \{a_2\}$, say a . By Lemma 2.5:(ii), we may suppose that $ap_1 \notin E(G)$. Since $\{a, p_1, q_2, v_3, v_4\}$ does not induce a $P_2 + P_3$, we have $aq_2 \notin E(G)$. Then $\{a, a_2, p_1, q_2, v_4, t^*\}$ is a stable set of size 6 (by Lemma 2.1:(i)), a contradiction. So we have $A_2 \setminus \{a_2\} = \emptyset$. This proves the first assertion of 2.23.7. Now suppose to the contrary that a_2 has a non-neighbor in A_4 , say a_4 . Since $\{a_2, v_2, p_1, a_4, v_4\}$ does not induce a $P_2 + P_3$, we have $a_4p_1 \notin E(G)$. Similarly, $a_4p_2 \notin E(G)$. Then $\{a_2, a_4, p_1, p_2, v_3, t^*\}$ is a stable set of size 6 (by Lemma 2.1:(i)), a contradiction. So $\{a_2\}$ is complete to A_4 . This proves 2.23.7. ■

So by 2.23.7 and Lemma 2.4:(iii), we have A_4 is complete to X_1 . Thus $\theta(G[A_2 \cup A_4 \cup X_1]) \leq 2$. Now $\theta(G) \leq \theta(G[A_1 \cup A_3 \cup X_2]) + \theta(G[A_2 \cup A_4 \cup X_1]) + \theta(G[B \cup C \cup D \cup T]) \leq 2 + 3 + 3 = 8$ (by Lemma 2.22 and Lemma 2.16:(v)). This proves Lemma 2.23. □

Lemma 2.24 If A_i is not anticomplete to A_{i+2} , for some $i \in \{1, 2, 3, 4\}$, then \overline{G} is a good graph.

Proof. We may assume that $i = 1$, and there are adjacent vertices, say $a_1 \in A_1$ and $a_3 \in A_3$. By Lemma 2.21, $|A'_1| \leq 1$ and $|A'_3| \leq 1$. By Lemma 2.1:(ii), $|A''_1| \leq 1$ and $|A''_3| \leq 1$. Also by Lemma 2.20 and Lemma 2.21, we may suppose that for each $j \in \{1, 2\}$, $G[A_j \cup A_{j+2}]$ is $(K_{1,3}, K_{2,2})$ -free. So by Lemma 2.23, if $\alpha(G) = 5$, then $\theta(G) \leq 8 = \alpha(G) + 3$; hence \overline{G} is a good graph. So we assume that either $\alpha(G) \geq 6$ or $\alpha(G) \leq 4$. Now we claim the following:

2.24.1 $\theta(G[A_2 \cup A_4 \cup X_1]) \leq 3$.

Proof of 2.24.1. We may assume that A_2 is anticomplete to A_4 (by Lemma 2.22). We partition X_1 as follows:

$$\begin{aligned} X'_1 &:= \{x \in X_1 \mid a_1x \in E(G)\}, \\ X''_1 &:= \{x \in X_1 \mid a_1x \notin E(G), a_3x \in E(G)\}, \text{ and} \\ X'''_1 &:= \{x \in X_1 \mid a_1x, a_3x \notin E(G)\}. \end{aligned}$$

By Lemma 2.2:(iii), $|X'_1| \leq 1$ and $|X''_1| \leq 1$. If there are vertices, say $x, x' \in X'''_1$, then $\{a_1, a_3, x, t^*, x'\}$ induces a $P_2 + P_3$ (by Lemma 2.2:(ii) and Lemma 2.17:(i)); so $|X'''_1| \leq 1$. Hence $|X_1| \leq 3$. If $A_2, A_4 \neq \emptyset$, then by Lemma 2.1:(ii), we have $|A_2| \leq 1$ and $|A_4| \leq 1$, and so by Lemma 2.17:(ii), $\theta(G[A_2 \cup A_4 \cup X_1]) \leq 3$, and we are done. If $A_4 = \emptyset$ (up to symmetry), then from

Lemma 2.4:(i) and Lemma 2.5:(ii), $|A_2| \leq 3$, and again by Lemma 2.17:(ii), $\theta(G[A_2 \cup A_4 \cup X_1]) \leq 3$. This proves 2.24.1. ■

Now from Lemma 2.16:(v), Lemma 2.22 and 2.24.1, $\theta(G) \leq 9$. If $\alpha(G) \geq 6$, then $\theta(G) \leq \alpha(G) + 3$. So it is enough to prove the lemma for $\alpha(G) \leq 4$. Since $T \cup \{a_1, v_2, v_4\}$ is a stable set of size 4 (by Lemma 2.1:(i) and since $T \neq \emptyset$), $\alpha(G) \geq 4$. Recall that $X_1 \cup \{v_2, v_4\}$ and $X_2 \cup \{v_1, v_3\}$ are stable sets (by Lemma 2.2:(ii)), and $A_i \cup T \cup \{v_{i+1}, v_{i-1}\}$ is a stable set, for each i (by Lemma 2.1:(i)). So we may assume that $\alpha(G) = 4$. Since $\alpha(G) = 4$, clearly $|X_1| \leq 2$, $|X_2| \leq 2$, and $|A_i| \leq 1$ for each i . For $j \in \{1, 2\}$, if there are non-adjacent vertices $a \in A_j$ and $a' \in A_{j+2}$, then since $T \cup \{a, a', v_{j+1}, v_{j-1}\}$ is a stable set of size of at least 5 (by Lemma 2.1:(i)), A_j is complete to A_{j+2} . Then from Lemma 2.4:(iii), $\theta(G[A_1 \cup A_3 \cup X_2]) \leq 2$ and $\theta(G[A_2 \cup A_4 \cup X_1]) \leq 2$. So by Lemma 2.16:(v), we conclude that $\theta(G) \leq 7 = \alpha(G) + 3$. Hence \overline{G} is a good graph. This proves Lemma 2.24. □

Lemma 2.25 *If G is a $(P_2 + P_3, \overline{P_2 + P_3}, K_2 + K_3, \text{Co-banner}, \overline{H_2})$ -free graph that contains an $\overline{H_3}$, then \overline{G} is a good graph.*

Proof. Let G be a $(P_2 + P_3, \overline{P_2 + P_3}, K_2 + K_3, \text{Co-banner}, \overline{H_2})$ -free graph that contains an $\overline{H_3}$. We may assume that \overline{G} does not have twins or a universal vertex. Suppose that G contains an $\overline{H_3}$ with vertices and edges as shown in Figure 9. Let $C := \{v_1, v_2, v_3, v_4\}$ and we partition $V(G) \setminus C$ as in Section 2.2. We split the proof into two cases depending on edges between A_i and A_{i+2} , where $i \in \{1, 2, 3, 4\}$, and the lemma follows from Lemma 2.19 and Lemma 2.24. □

Theorem 2.26 *If G is a $(P_2 + P_3, \overline{P_2 + P_3}, K_{2,3}, \text{banner}, H_2)$ -free graph that contains an H_3 , then G is a good graph.*

Proof. The proof follows from Lemma 2.25. □

2.5 $(P_2 + P_3, \overline{P_2 + P_3}, K_{2,3})$ -free graphs that contain a C_4

We start with the following. Let G be a $(P_2 + P_3, \overline{P_2 + P_3}, K_{2,3}, \text{banner}, H_2, H_3)$ -free graph which does not have twins or a universal vertex. Suppose that G contains a C_4 , say with vertex-set $C := \{v_1, v_2, v_3, v_4\}$ and edge-set $\{v_1v_2, v_2v_3, v_3v_4, v_4v_1\}$. We partition $V(G) \setminus C$ as in Section 2.2, and we use the lemmas in Section 2.2. Clearly since G is $K_{2,3}$ -free, $X = \emptyset$, and since G is banner-free, $A = \emptyset$. Moreover, the graph G has some more properties which we give in Lemmas 2.27 to 2.29 below.

Lemma 2.27 *For $i \in \{1, 2, 3, 4\}$, the following hold:*

- (i) B_i is complete to $B_{i+1} \cup B_{i-1}$.
- (ii) If $B_{i+1} \neq \emptyset$, then B_i is a clique.

Proof. (i): If there are non-adjacent vertices, say $b \in B_i$ and $b' \in B_{i+1} \cup B_{i-1}$, then $C \cup \{b, b'\}$ induces an H_3 . So Lemma 2.27:(i) holds. ■

(ii): If there are non-adjacent vertices in B_i , say b and b' , then for any $b'' \in B_{i+1}$, by Lemma 2.27:(i), $\{b, v_i, b', b'', v_{i-1}\}$ induces a banner. So Lemma 2.27:(ii) holds. \square

Lemma 2.28 *If B_i and B_{i+2} are empty, for some $i \in \{1, 2, 3, 4\}$, then G is a good graph.*

Proof. We may assume that $B_2 \cup B_4 = \emptyset$. If B_1 is anticomplete to B_3 , then we define $S_1 := \{v_1, v_3\}$, $S_2 := \{v_2\}$ and $S_3 := T \cup \{v_4\}$. Then by Lemma 2.1:(i), clearly S_1, S_2 and S_3 are stable sets such that $\omega(G - (S_1 \cup S_2 \cup S_3)) \leq \omega(G) - 2$, and G is a nice graph. So we may suppose that, there are adjacent vertices, say $b_1 \in B_1$ and $b_3 \in B_3$. Now we claim the following:

2.28.1 *B_1 is a clique. Likewise, B_3 is a clique.*

Proof of 2.28.1. Suppose to the contrary that there are non-adjacent vertices, say $b, b' \in B_1$. If $b, b' \neq b_1$, then by Lemma 2.1:(v), $\{b_3, v_4, b, v_2, b'\}$ induces a $P_2 + P_3$, and if $b = b_1$, then $\{b_1, b_3, v_4, v_1, b'\}$ induces a banner or a $K_{2,3}$; so we conclude that B_1 is a clique. Likewise, B_3 is a clique. This proves 2.28.1. \blacksquare

Now if $D = \emptyset$, then by Lemma 2.1:(v), $G[B_1 \cup B_3 \cup C]$ is the complement of a bipartite graph, and then by Lemma 2.1:(i), we have $\chi(G) \leq \omega(G) + 3$ and we are done; so $D \neq \emptyset$. If there is a vertex, say $d \in D$ such that $\{d\}$ is complete to either B_1 or B_3 , then we let $S_1 := \{d\}$, otherwise let S_1 be a maximum stable set in $G[B_1 \cup B_3 \cup D]$ such that $D \cap S_1 \neq \emptyset$ and $(B_1 \cup B_3) \cap S_1 \neq \emptyset$. Let $S_2 := T \cup \{v_1, v_3\}$ and $S_3 := \{v_2, v_4\}$. Then S_1, S_2 and S_3 are stable sets. Next we claim the following:

2.28.2 *For any maximum clique Q in $G - (S_1 \cup S_2 \cup S_3)$, we have $|Q| \leq \omega(G) - 2$.*

Proof of 2.28.2. Suppose not, and let K be a maximum clique in $G - (S_1 \cup S_2 \cup S_3)$ such that $|K| \geq \omega(G) - 1$. Since $\{v_1, v_2\}$ is complete to $B_1 \cup D$, and $\{v_3, v_4\}$ is complete to $B_3 \cup D$, we may assume that, $K \cap B_1, K \cap B_3 \neq \emptyset$. By Lemma 2.1:(v), we let $K \cap B_1 := \{b'_1\}$ and $K \cap B_3 := \{b'_3\}$. If $D \cap S_1$ is not anticomplete to K , then for any $d' \in (D \cap S_1) \cap N(b'_1)$, clearly $(K \setminus \{b'_3\}) \cup \{d', v_1, v_2\}$ is a clique of size at least $\omega(G) + 1$ (by Lemma 2.2:(i)), a contradiction; so $D \cap S_1$ is anticomplete to K . Moreover, if $B_1 \cap S_1 = \emptyset$, then by Lemma 2.1:(v), $S_1 \cup \{b'_1\}$ is a stable set which contradicts the choice of S_1 ; so $B_1 \cap S_1 \neq \emptyset$. Likewise, $B_3 \cap S_1 \neq \emptyset$. Then for any $p \in B_1 \cap S_1$, $q \in B_3 \cap S_1$ and $r \in D \cap S_1$, $\{q, b'_3, p, v_1, r\}$ induces a $P_2 + P_3$ (by Lemma 2.1:(v)), a contradiction. This proves 2.28.2. \blacksquare

So by 2.28.2, $\omega(G - (S_1 \cup S_2 \cup S_3)) \leq \omega(G) - 2$, and G is a nice graph. This proves Lemma 2.28. \square

Lemma 2.29 *If B_i is complete to B_{i+2} , for each $i \in \{1, 2, 3, 4\}$, then G is a good graph.*

Proof. Since $N(v_i) = B_i \cup B_{i-1} \cup D \cup \{v_{i+1}, v_{i-1}\}$, and since v_i and v_{i+2} are not twins, we may suppose that B_1 and B_3 are non-empty. Then by Lemma 2.1:(v), $|B_1| = 1$ and $|B_3| = 1$. By Lemma 2.28, we may suppose that $B_2 \neq \emptyset$. So by Lemma 2.27:(ii), we may suppose that B_i is a

clique, for each i . First suppose that $B_4 \neq \emptyset$. So again by Lemma 2.1:(v), $|B_i| = 1$, for each i . For $i \in \{1, 2, 3, 4\}$, we define $W_i := B_i \cup \{v_{i+2}\}$ and $W_5 := T$. Then clearly W_i 's are stable sets, and hence $\chi(G) \leq \omega(G) + 3$ (by Lemma 2.3:(ii)), and we are done. So we may conclude that $B_4 = \emptyset$, and we define $S_1 := B_1 \cup \{v_3\}$, $S_2 := B_3 \cup \{v_1\}$ and $S_3 := T \cup \{v_2, v_4\}$. Then S_1, S_2 and S_3 are three stable sets. Now if there is a clique, say $Q \in G - (S_1 \cup S_2 \cup S_3)$ such that $|Q| > \omega(G) - 2$, then $Q \cap (B_2 \cup D) \neq \emptyset$, and then $Q \cup \{v_2, v_3\}$ is a clique of size $\omega(G) + 1$, a contradiction. So $\omega(G - (S_1 \cup S_2 \cup S_3)) \leq \omega(G) - 2$, and hence G is a nice graph. This proves Lemma 2.29. \square

Now we prove the main result of this section, and is given below.

Theorem 2.30 *If G is a $(P_2 + P_3, \overline{P_2 + P_3}, K_{2,3})$ -free graph that contains a C_4 , then G is a good graph.*

Proof. Let G be a $(P_2 + P_3, \overline{P_2 + P_3}, K_{2,3})$ -free graph. Suppose that G contains a C_4 , say with vertex-set $C := \{v_1, v_2, v_3, v_4\}$ and edge-set $\{v_1v_2, v_2v_3, v_3v_4, v_4v_1\}$. We partition $V(G) \setminus C$ as in Section 2.2, and we use the lemmas in Section 2.2. By Theorem 2.13, Theorem 2.14 and Theorem 2.26, we may suppose that G is (banner, H_2, H_3)-free. As earlier, since G is $K_{2,3}$ -free, $X = \emptyset$, and since G is banner-free, $A = \emptyset$. Also T is a stable set (by Lemma 2.1:(i)). We may assume that G does not have twins or a universal vertex, and we use Lemmas 2.27 to 2.29. Recall that, by Lemma 2.27:(i), for each $i \in \{1, 2, 3, 4\}$, B_i is complete to B_{i+1} . By Lemmas 2.28 and 2.29, we may suppose that there are vertices $b_1 \in B_1, b_2 \in B_2$ and $b_3 \in B_3$ such that $b_1b_2, b_2b_3 \in E(G)$ and $b_1b_3 \notin E(G)$. Then by Lemma 2.27:(ii), for each $i \in \{1, 2, 3, 4\}$, B_i is a clique. If $D = \emptyset$, then since $B_1 \cup B_2 \cup \{v_2\}$ and $B_3 \cup B_4 \cup \{v_4\}$ are cliques, $B \cup \{v_2, v_4\}$ induces the complement of a bipartite graph, and hence $\chi(G) \leq \chi(G[B \cup \{v_2, v_4\}]) + \chi(G[T \cup \{v_1, v_3\}]) \leq \omega(G) + 1$. So we may suppose that $D \neq \emptyset$, and we claim the following:

2.30.1 *Any vertex in D which is complete to $\{b_1, b_3\}$, is complete to $B_2 \cup B_4$. Also any vertex in D which is anticomplete to $\{b_1, b_3\}$, is anticomplete to $B_2 \cup B_4$.*

Proof of 2.30.1. Let $d \in D$. If $db_1, db_3 \in E(G)$, and there is a vertex $b \in B_2$ (up to symmetry) such that $db \notin E(G)$, then $\{b_1, b, v_3, d, b_3\}$ induces a $\overline{P_2 + P_3}$. If $db_1, db_3 \notin E(G)$, and there is a vertex $b' \in B_2$ (up to symmetry) such that $db' \in E(G)$, then $\{b_1, b', d, v_1, b_3\}$ induces a banner. This proves 2.30.1. \blacksquare

Let $B' := \{b_1, b_2, b_3\}$. To proceed further, we let:

$$\begin{aligned} D_1 &:= \{d \in D \mid N(d) \cap B' = \{b_1\}\}, & D'_1 &:= \{d \in D \mid N(d) \cap B' = \{b_3\}\}, \\ D_2 &:= \{d \in D \mid N(d) \cap B' = \{b_1, b_2\}\}, & D'_2 &:= \{d \in D \mid N(d) \cap B' = \{b_2, b_3\}\}, \\ D_3 &:= \{d \in D \mid N(d) \cap B' = B'\}, & \text{and} & \quad D'_3 := \{d \in D \mid N(d) \cap B' = \emptyset\}. \end{aligned}$$

Then by 2.30.1, $D = \bigcup_{j=1}^3 D_j \cup D'_j$ and by Lemma 2.1:(iii), D_1, D'_1, D_2, D'_2 and D_3 are cliques. Moreover:

2.30.2 *$D_1 \cup D'_2$ is a stable set. Likewise, $D_2 \cup D'_1$ is a stable set.*

Proof of 2.30.2. If there are vertices, say $d, d' \in D_1$, then $\{b_1, b_2, v_3, d, d'\}$ induces a $\overline{P_2 + P_3}$; so $|D_1| \leq 1$. By using a similar argument, we conclude that $|D'_2| \leq 1$. If there are adjacent vertices, say $d \in D_1$ and $d' \in D'_2$, then $\{b_1, d, d', b_2, v_1\}$ induces a $\overline{P_2 + P_3}$. So $D_1 \cup D'_2$ is a stable set. Likewise, $D_2 \cup D'_1$ is also a stable set. This proves 2.30.2. ■

2.30.3 $|D'_3| \leq 1$.

Proof of 2.30.3. If there are vertices, say $d, d' \in D'_3$, then since $\{d, d', b_1, b_2, b_3\}$ does not induce a $P_2 + P_3$, we have $d_1 d_2 \notin E(G)$, and then $\{b_1, b_2, d, v_4, d'\}$ induces a $P_2 + P_3$; so $|D'_3| \leq 1$. This proves 2.30.3. ■

Now we prove the theorem in three cases as follows:

Case 1 Suppose that the set $D_1 \cup D'_1$ is non-empty.

We may assume, up to symmetry, that there is a vertex, say $d \in D_1$. Then:

2.30.4 $|B_2| \leq 2$ and $|B_4| \leq 2$. Moreover, $\chi(G[B_2 \cup B_4]) \leq 2$.

Proof of 2.30.4. If there are vertices, say $b, b' \in B_2 \setminus \{b_2\}$, then since $\{b, b_3, v_4, d, b'\}$ does not induce a $\overline{P_2 + P_3}$, we may suppose that $bd \notin E(G)$, and then $\{b_1, b_2, v_3, d, b\}$ induces a $\overline{P_2 + P_3}$; so $|B_2| \leq 2$. If there are vertices, say $p, q, r \in B_4$, then since $\{b_3, v_3, d, p, q\}$ does not induce a $\overline{P_2 + P_3}$, we may suppose that $pd \notin E(G)$, and then we get a similar contradiction as in the proof for $|B_2| \leq 2$. So $|B_4| \leq 2$. This proves the first assertion. The second assertion follows from the first assertion and from Lemma 2.1:(v). This proves 2.30.4. ■

Case 1.1 Suppose that the set $B_1 \setminus \{b_1\}$ is non-empty.

Then we have the following claim:

2.30.5 $\chi(G[B_1 \cup B_3 \cup D_3 \cup D'_3]) \leq \omega(G) - |B_2| - 1$. Likewise, $\chi(G[B_1 \cup B_3 \cup D_3 \cup D'_3]) \leq \omega(G) - |B_4| - 1$.

Proof of 2.30.5. For any $b \in (B_1 \setminus \{b_1\}) \cup (B_3 \setminus N(b_1))$, since $\{b_1, b_2, v_3, d, b\}$ does not induce a $\overline{P_2 + P_3}$, $\{d\}$ is anticomplete to $(B_1 \setminus \{b_1\}) \cup (B_3 \setminus N(b_1))$. Now if there are non-adjacent vertices, say $b' \in B_1 \setminus \{b_1\}$ and $b'' \in B_3 \setminus N(b_1)$, then $\{b_1, b_2, v_3, d, b', b''\}$ induces an H_3 ; so $B_1 \setminus \{b_1\}$ is complete to $B_3 \setminus N(b_1)$. Then since $b_3 \in B_3 \setminus N(b_1)$, by Lemma 2.1:(v), $|B_1 \setminus \{b_1\}| = 1$ (so $|B_1| = 2$), and $B_3 \setminus N(b_1) = \{b_3\}$. Hence D_3 is complete to $B_1 \setminus \{b_1\}$ (by Lemma 2.2:(i)), and so $D_3 \cup B_1 \cup B_2 \cup \{v_2\}$ is a clique (by 2.30.1). By 2.30.3, $D'_3 \cup \{b_1, b_3\}$ is a stable set. By Lemma 2.1:(v), $(B_1 \setminus \{b_1\}) \cup (B_3 \setminus \{b_3\})$ is a stable set. These conclusions imply that $\chi(G[B_1 \cup B_3 \cup D_3 \cup D'_3]) \leq \omega(G[D_3]) + \chi(G[D'_3 \cup \{b_1, b_3\}]) + \chi(G[(B_1 \setminus \{b_1\}) \cup (B_3 \setminus \{b_3\})]) = (\omega(G[D_3 \cup B_1 \cup B_2 \cup \{v_2\}]) - |B_1| - |B_2| - 1) + 2 \leq \omega(G) - 2 - |B_2| + 1 = \omega(G) - |B_2| - 1$. Likewise, $\chi(G[B_1 \cup B_3 \cup D_3]) \leq \omega(G) - |B_4| - 1$. This proves 2.30.5. ■

By 2.30.2, $\chi(G[D_1 \cup D'_1 \cup D_2 \cup D'_2]) \leq 2$. So by 2.30.5, $\chi(G[B_1 \cup B_3 \cup D]) \leq \omega(G) - |B_2| + 1$ and $\chi(G[B_1 \cup B_3 \cup D]) \leq \omega(G) - |B_4| + 1$. Now if $|B_2| = 1$ and $|B_4| \leq 1$, then since $B_2 \cup \{v_1\}$,

$B_4 \cup \{v_3\}$ and $T \cup \{v_2, v_4\}$ are stable sets, we conclude that $\chi(G) \leq \omega(G) + 3$. So by 2.30.4, we may suppose that either $|B_2| = 2$ or $|B_4| = 2$. In any case, $\chi(G[B_1 \cup B_3 \cup D]) \leq \omega(G) - 1$. Then since $T \cup \{v_2, v_4\}$ and $\{v_1, v_3\}$ are stable sets, and $\chi(G[B_2 \cup B_4]) \leq 2$ (by 2.30.4), we see that $\chi(G) \leq \omega(G) + 3$.

Case 1.2 Suppose that the set $B_1 \setminus \{b_1\}$ is empty.

If $B_3 \setminus \{b_3\} = \emptyset$, then since $\{b_1, v_3\}$, $\{b_3, v_1\}$ and $T \cup \{v_2, v_4\}$ are stable sets, and since $\chi(G[B_2 \cup B_4]) \leq 2$ (by 2.30.4), clearly $\chi(G) \leq \chi(G - D) + \chi(G[D]) \leq 5 + (\omega(G) - 2) = \omega(G) + 3$ (by Lemma 2.3:(ii)). So we may suppose that $B_3 \setminus \{b_3\} \neq \emptyset$. Now if there is a vertex, say $d_1 \in D'_1$, then $b_3d_1 \in E(G)$, $b_1d_1, b_2d_1 \notin E(G)$ and $B_3 \setminus \{b_3\} \neq \emptyset$, and thus this case (up to relabeling) is similar to Case 1.1, and we proceed in Case 1.1 to complete the proof. So we may assume that $D'_1 = \emptyset$. Also:

2.30.6 We may assume that $|B_4| \leq 1$.

Proof of 2.30.6. If there are vertices, say $b_4, b'_4 \in B_4$, then by Lemma 2.1:(v), we may suppose that $b_2b_4 \notin E(G)$, and then since $\{b_1, b_2, b_3, b_4, d\}$ does not induce a banner, $b_4d \in E(G)$. Now since $b_3d, b_2d, b_2b_4 \notin E(G)$ and $B_4 \setminus \{b_4\} \neq \emptyset$, this case (up to relabeling) is similar to Case 1.1, and we proceed in Case 1.1 to complete the proof. So we may conclude that $|B_4| \leq 1$. ■

By 2.30.6 and Lemma 2.1:(i), $\{b_1, v_4\}$, $B_4 \cup \{v_2\}$ and $T \cup \{v_1, v_3\}$ are stable sets. By 2.30.2, $D_1 \cup \{b_2\}$ is a stable set. By 2.30.1, 2.30.3 and 2.30.4, $(B_2 \setminus \{b_2\}) \cup D'_3$ is a stable set. Hence $\chi(G[B_1 \cup B_2 \cup B_4 \cup D_1 \cup D'_3]) \leq 5$. Since $D \setminus (D_1 \cup D'_3)$ is complete to $\{b_2\}$, $D \setminus (D_1 \cup D'_3)$ is a clique (by Lemma 2.1:(iii)). Thus $G[B_3 \cup (D \setminus (D_1 \cup D'_3))]$ is the complement of a bipartite graph, and hence a perfect graph. Since $\{v_3, v_4\}$ is complete to $B_3 \cup (D \setminus (D_1 \cup D'_3))$, $\chi(G[B_3 \cup (D \setminus (D_1 \cup D'_3))]) \leq \omega(G) - 2$. Hence $\chi(G) \leq \omega(G) + 3$ and so G is a good graph. This proves the theorem in Case 1.

Case 2 Suppose that the set $D_1 \cup D'_1$ is empty and the set $D_2 \cup D'_2$ is non-empty.

We may assume, up to symmetry, that there is a vertex, say $d \in D_2$. Then $b_1d, b_2d \in E(G)$, and $b_3d \notin E(G)$. Also:

2.30.7 We may assume that $B_2 = \{b_2\}$.

Proof of 2.30.7. If there is a vertex, say $b'_2 \in B_2 \setminus \{b_2\}$, then since $\{b_2, b_3, v_4, d, b'_2\}$ does not induce a $\overline{P_2 + P_3}$, $b'_2d \notin E(G)$. Now, we see that there is a vertex $d \in D$ such that $b_1d \in E(G)$ and $b'_2d, b_3d \notin E(G)$, and this case (up to relabeling) is similar to Case 1, and we proceed as in Case 1 to complete the proof. So we may conclude that $B_2 = \{b_2\}$. ■

2.30.8 We may assume B_4 is complete to $\{b_2\}$.

Proof of 2.30.8. Suppose there is a vertex, say $b_4 \in B_4$ such that $b_2b_4 \notin E(G)$. Then since $\{b_1, b_2, b_3, b_4, d\}$ does not induce a $\overline{P_2 + P_3}$, $b_4d \notin E(G)$. Now, we see that there is a vertex $d \in D$

such that $b_2d \in E(G)$ and $b_3d, b_4d \notin E(G)$, and this case (up to relabeling) is similar to Case 1, and we proceed as in Case 1 to complete the proof. So we may assume B_4 is complete to $\{b_2\}$. ■

2.30.9 *We may assume that $B_1 \cup B_3$ is anticomplete to D'_3 .*

Proof of 2.30.9. Suppose there are adjacent vertices, say $b \in B_1$ and $d' \in D'_3$. Then by Lemma 2.2:(i), $bb_3 \notin E(G)$. Now, we see that there is a vertex $d' \in D$ such that $bd' \in E(G)$ and $b_2d', b_3d' \notin E(G)$, and this case (up to relabeling) is similar to Case 1, and we proceed as in Case 1 to complete the proof. So we may conclude that B_1 is anticomplete to D'_3 . Likewise, we may assume that B_3 is anticomplete to D'_3 . So we may assume that $B_1 \cup B_3$ is anticomplete to D'_3 . ■

2.30.10 *$\{d\}$ is complete to $(B_1 \setminus N(b_3)) \cup (B_3 \setminus \{b_3\}) \cup (D \setminus \{d\})$.*

Proof of 2.30.10. Suppose there is a vertex, say $p \in (B_1 \setminus N(b_3)) \cup (B_3 \setminus \{b_3\}) \cup (D \setminus \{d\})$ such that $pd \notin E(G)$. If $p \in B_1 \setminus N(b_3)$, then $\{p, b_2, d, v_1, b_3\}$ induces a banner. If $p \in B_3 \setminus \{b_3\}$, then $\{b_2, b_3, v_4, d, p\}$ induces a $\overline{P_2 + P_3}$. Since $\{b_2\}$ is complete to $D \setminus D'_3$, by Lemma 2.1:(iii), $D \setminus D'_3$ is a clique; so $\{d\}$ is complete to $D \setminus D'_3$. So we conclude that $p \in D'_3$. But then $\{d, v_1, p, v_3, b_3\}$ induces a banner. So 2.30.10 holds. ■

2.30.11 *We may assume that B_4 is empty.*

Proof of 2.30.11. By Lemma 2.1:(v) and 2.30.8, $|B_4| = 1$. By Lemma 2.2:(i) and 2.30.8, B_4 is complete to $D \setminus D'_3$. Now we define three stable sets, say $W_1 := \{b_2, v_4\}$, $W_2 := B_4 \cup \{v_2\}$ and $W_3 := T \cup \{v_1, v_3\}$. We claim that for any maximum clique Q in $G - (W_1 \cup W_2 \cup W_3)$, $|Q| \leq \omega(G) - 2$. Suppose not, and let K be a maximum clique in $G - (W_1 \cup W_2 \cup W_3)$ such that $|K| \geq \omega(G) - 1$. Since for $j \in \{1, 3\}$, $\{v_j, v_{j+1}\}$ is complete to $B_j \cup D$, we may suppose that $K \cap B_1 \neq \emptyset$ and $K \cap B_3 \neq \emptyset$. Then by 2.30.9, $K \cap D'_3 = \emptyset$. Since $B_4 \cup \{b_2\}$ is complete to $B_1 \cup B_3 \cup (D \setminus D'_3)$, we see that $K \cup B_4 \cup \{b_2\}$ is a clique of size $\omega(G) + 1$, a contradiction. So $\omega(G - (W_1 \cup W_2 \cup W_3)) \leq \omega(G) - 2$, and hence G is a nice graph. So we may assume that $B_4 = \emptyset$. ■

Now we define three stable sets, say $S_1 := \{b_3, d\}$, $S_2 := \{b_2, v_1\}$, and $S_3 := T \cup \{v_2, v_4\}$, and we claim the following:

2.30.12 *For any maximum clique Q in $G - (S_1 \cup S_2 \cup S_3)$, we have $|Q| \leq \omega(G) - 2$.*

Proof of 2.30.12. Suppose not, and let K be a maximum clique in $G - (S_1 \cup S_2 \cup S_3)$ such that $|K| \geq \omega(G) - 1$. If $K \cap B_1 = \emptyset$, then by 2.30.10, $K \cup \{v_4, d\}$ is a clique of size at least $\omega(G) + 1$, a contradiction; so $K \cap B_1 \neq \emptyset$. If $K \cap B_3 \neq \emptyset$, then $K \cap B_3$ is complete to $\{d\}$ (by 2.30.10), $K \cap B_1$ is complete to $\{d\}$ (by Lemma 2.2:(i)), and then $K \cup \{b_2, d\}$ is a clique of size at least $\omega(G) + 1$, a contradiction; so $K \cap B_3 = \emptyset$. Then $|K \cup \{v_1, v_2\}| \geq \omega(G) + 1$, a contradiction. This proves 2.30.12. ■

Hence by 2.30.12, G is a good graph.

Case 3 Suppose that the set $D_1 \cup D'_1 \cup D_2 \cup D'_2$ is empty.

Suppose that there are non-adjacent vertices, say $b \in B_1$ and $d \in D_3$, then by Lemma 2.1:(v), $bb_3 \notin E(G)$. Now, we see that there is a vertex $d \in D$ such that $b_2d, b_3d \in E(G)$ and $bd \notin E(G)$, and this case (up to relabeling) is similar to Case 2, so we proceed as in Case 2 to complete the proof. So we may assume that B_1 is complete to D_3 . Likewise, we may assume that B_3 is complete to D_3 . Since $B_1 \cup B_2$ and $B_3 \cup B_4$ are cliques, $G[B]$ induces the complement of a bipartite graph. Also by 2.30.1, D_3 is complete to B . So $G[B \cup D_3]$ induces a perfect graph. By 2.30.3, since $D'_3, \{v_2, v_4\}$ and $T \cup \{v_1, v_3\}$ are stable sets, we conclude that $\chi(G) \leq \omega(G) + 3$. So G is a good graph. \square

2.6 $(P_2 + P_3, \overline{P_2 + P_3})$ -free graphs that contain a C_4

Theorem 2.31 *If G is a $(P_2 + P_3, \overline{P_2 + P_3})$ -free graph that contains a C_4 , then G is a good graph.*

Proof. If G contains a $K_{2,3}$ then the theorem follows from Theorem 2.7. So we assume that G is $K_{2,3}$ -free, and then the theorem follows from Theorem 2.30. \square

2.7 Chromatic bound for $(P_2 + P_3, \overline{P_2 + P_3})$ -free graphs

In this section, we prove the smallest χ -binding function for the class of $(P_2 + P_3, \overline{P_2 + P_3})$ -free graphs. We first prove few lemmas.

Lemma 2.32 *If G is a nice graph with $\omega(G) \geq 3$, then $\chi(G) \leq \lfloor \frac{3}{2}\omega(G) \rfloor - 1$.*

Proof. Let G be a nice graph. Then G has three pairwise disjoint stable sets, say S_1, S_2 and S_3 , such that $\omega(G - (S_1 \cup S_2 \cup S_3)) \leq \omega(G) - 2$. Let $S := S_1 \cup S_2 \cup S_3$. We prove the lemma by induction on $|V(G)|$. Since $\chi(G) \leq \chi(G - S) + \chi(G[S])$, by induction hypothesis, $\chi(G) \leq (\lfloor \frac{3}{2}\omega(G - S) \rfloor - 1) + 3 \leq (\lfloor \frac{3}{2}(\omega(G) - 2) \rfloor - 1) + 3 \leq \lfloor \frac{3}{2}\omega(G) \rfloor - 1$. This proves Lemma 2.32. \square

Lemma 2.33 *If a graph G has a nice vertex with $\omega(G) \geq 3$, then $\chi(G) \leq \omega(G) + 3$.*

Proof. Suppose that the graph G has a nice vertex, say u . We prove the lemma by induction on $|V(G)|$. Now since $d_G(u) \leq \omega(G) + 2$, we can take any $\chi(G)$ -coloring of $G - u$ and extend it to a $\chi(G)$ -coloring of G , using for u a color (possibly new) that does not appear in $N_G(u)$. So $\chi(G) \leq \omega(G) + 3$. This proves Lemma 2.33. \square

Lemma 2.34 *If G is a good graph with $\omega(G) \geq 3$, then $\chi(G) \leq \max\{\omega(G) + 3, \lfloor \frac{3}{2}\omega(G) \rfloor - 1\}$.*

Proof. Let G be a good graph. If $\chi(G) \leq \omega(G) + 3$ or if G is a nice graph or if G has a nice vertex, then the lemma follows from Lemmas 2.32 and 2.33. So we may suppose that either G has twins or a universal vertex. Now we prove the lemma by induction on $|V(G)|$. If G has a universal vertex, say u , then $\omega(G - u) = \omega(G) - 1$, and then $\chi(G) = \chi(G - u) + 1 \leq$

$\max\{\omega(G - u) + 3, \lfloor \frac{3}{2}\omega(G - u) \rfloor - 1\} + 1 \leq \max\{\omega(G) + 3, \lfloor \frac{3}{2}\omega(G) \rfloor - 1\}$, we are done. Finally, suppose that G has twins, say u and v . Then we may suppose that $N_G(u) \subseteq N_G(v)$, and so $\chi(G) = \chi(G - u)$ and $\omega(G) = \omega(G - u)$. Now we can take any $\chi(G)$ -coloring of $G - u$ and extend it to a $\chi(G)$ -coloring of G , using for u the color of v . This proves Lemma 2.34. \square

Theorem 2.35 *Every $(P_2 + P_3, \overline{P_2 + P_3})$ -free graph G with $\omega(G) \geq 3$ satisfies $\chi(G) \leq \max\{\omega(G) + 3, \lfloor \frac{3}{2}\omega(G) \rfloor - 1\}$.*

Proof. Let G be a $(P_2 + P_3, \overline{P_2 + P_3})$ -free graph. By Theorem D, if G is C_4 -free, then $\chi(G) \leq \lceil \frac{5}{4}\omega(G) \rceil \leq \max\{\omega(G) + 3, \lfloor \frac{3}{2}\omega(G) \rfloor - 1\}$. So we may suppose that G contains a C_4 . Then G is a good graph (by Theorem 2.31), and then the proof follows from Lemma 2.34. \square

To prove that the bound given in Theorem 2.35 is tight, we first consider the following $(P_2 + P_3, \overline{P_2 + P_3})$ -free graphs, where $t \in \mathbb{N}$:

(A) Let L be the 16-regular *Schläfli graph* on 27 vertices (see Figure 5). Then:

- $\chi(L) = 9$ and $\omega(L) = 6$.
- $\chi(\overline{L}) = 6$ and $\omega(\overline{L}) = 3$ (see Figure 6).
- $\chi(L \vee K_t) = t + 9$ and $\omega(L \vee K_t) = t + 6$.
- $\chi(\overline{L} \vee K_t) = t + 6$ and $\omega(\overline{L} \vee K_t) = t + 3$.

(B) Let H be the complement of the *Clebsch graph* on 16 vertices (see Figure 4). Then:

- $\chi(H) = 8$ and $\omega(H) = 5$ (see Figure 4).
- If $H^* = H - v$, for any $v \in V(H)$, then $\chi(H^*) = 8$ and $\omega(H^*) = 5$ (see Figure 4).
- $\chi(H \vee K_t) = t + 8$ and $\omega(H \vee K_t) = t + 5$.
- $\chi(H^* \vee K_t) = t + 8$ and $\omega(H^* \vee K_t) = t + 5$.

We refer to Chudnovsky and Seymour [45] for a precise definition of the Schläfli graph and its properties. It is interesting to note that the set of neighbors of any vertex in the 16-regular Schläfli graph on 27 vertices induces the complement of the Clebsch graph on 16 vertices. The following theorem shows that the bound given in Theorem 2.35 is tight.

Theorem 2.36 *For every $\ell \in \mathbb{N}$ and $\ell \geq 3$, there is a $(P_2 + P_3, \overline{P_2 + P_3})$ -free graph G with $\omega(G) = \ell$ and $\chi(G) = \max\{\ell + 3, \lfloor \frac{3}{2}\ell \rfloor - 1\}$.*

Proof. Let L be the 16-regular *Schläfli graph* on 27 vertices, H be the complement of the *Clebsch graph* on 16 vertices, and H^* be the complement of the *Clebsch graph* on 16 vertices after deleting a vertex. For $\ell \in \{3, 4, \dots, 9\}$, consider the graphs G given in Table 2. Clearly each G is $(P_2 + P_3, \overline{P_2 + P_3})$ -free with $\omega(G) = \ell$ and $\chi(G) = \ell + 3$.

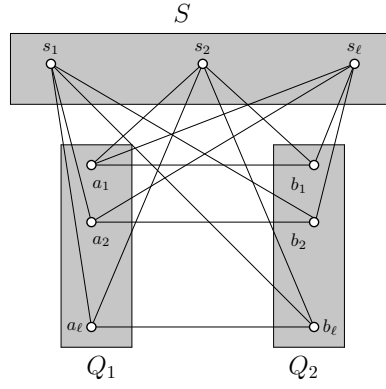
 Figure 10: Schematic representation of the graph \mathbb{G}_ℓ . (The vertices in a box form a clique.)

$\omega(G) = \ell$	G	$\chi(G)$
3	\overline{L}	6
4	$\overline{L} \vee K_1$	7
5	$\overline{L} \vee P_2$ or H or H^*	8
6	L or $\overline{L} \vee K_3$ or $H \vee K_1$ or $H^* \vee K_1$	9
$\ell \in \{7, 8, 9\}$	$L \vee K_{\ell-6}$ or $\overline{L} \vee K_{\ell-3}$ or $H \vee K_{\ell-5}$ or $H^* \vee K_{\ell-5}$	$\ell + 3$

 Table 2: Extremal $(P_2 + P_3, \overline{P_2 + P_3})$ -free graphs G for $\omega(G) \in \{3, 4, \dots, 9\}$.

So we may suppose that $\ell \geq 10$. Consider the graph \mathbb{G}_ℓ [92] defined as follows (see Figure 10):

- $V(\mathbb{G}_\ell) := Q_1 \cup Q_2 \cup S$, where $Q_1 := \{a_1, a_2, \dots, a_{\ell-1}\}$, $Q_2 := \{b_1, b_2, \dots, b_{\ell-1}\}$, and $S := \{s_1, s_2, \dots, s_{\ell-1}\}$ are cliques.
- For each $i \in \{1, 2, \dots, \ell-1\}$, a_i is adjacent to b_i , and $\{a_i\}$ is anticomplete to $Q_2 \setminus \{b_i\}$.
- For each $i \in \{1, 2, \dots, \ell-1\}$, $\{s_i\}$ is anticomplete to $\{a_i, b_i\}$, and complete to $(Q_1 \cup Q_2) \setminus \{a_i, b_i\}$.
- No other edges in \mathbb{G}_ℓ .

It is easy to verify that the graph \mathbb{G}_ℓ is $(P_2 + P_3, \overline{P_2 + P_3})$ -free, $|V(\mathbb{G}_\ell)| = 3\ell - 3$, $\omega(\mathbb{G}_\ell) = \ell$, and $\alpha(\mathbb{G}_\ell) = 2$; see also [92]. Also by Lemma 4 of [92], we have $\chi(\mathbb{G}_\ell) \leq \lceil \frac{3}{2}(\ell - 1) \rceil$. Moreover, since $\chi(\mathbb{G}_\ell) \geq \frac{|V(\mathbb{G}_\ell)|}{\alpha(\mathbb{G}_\ell)}$ and $\chi(\mathbb{G}_\ell) \leq \lceil \frac{3}{2}(\ell - 1) \rceil$, we conclude that $\chi(\mathbb{G}_\ell) = \lfloor \frac{3}{2}\ell \rfloor - 1$. Since for $\ell \geq 10$, $\max\{\ell + 3, \lfloor \frac{3}{2}\ell \rfloor - 1\} = \lfloor \frac{3}{2}\ell \rfloor - 1$, the graph \mathbb{G}_ℓ is our desired graph G . \square

Theorem 2.37 *The function $g : \mathbb{N} \rightarrow \mathbb{N}$ defined by $g(1) = 1$, $g(2) = 4$, and $g(x) = \max\{x + 3, \lfloor \frac{3}{2}x \rfloor - 1\}$, for $x \geq 3$, is the smallest χ -binding (or θ -binding) function for the class of $(P_2 + P_3, \overline{P_2 + P_3})$ -free graphs.*

Proof. The proof follows from Theorem C, Theorem 2.35 and Theorem 2.36. \square

2.8 Conclusion

In this chapter, we have obtained the smallest χ -binding function for the class of $(P_2 + P_3, \overline{P_2 + P_3})$ -free graphs via structure theorems by using some intermediate results which rely on certain special graphs. This partially answers a long-standing open problem of Gyárfás, namely Problem 2 when $F = P_2 + P_3$. Also, we note that our result generalizes/improves several previously mentioned known results in literature which are given in Table 3.

Graph Class \mathcal{G}	χ -bound for $G \in \mathcal{G}$	References
$(2P_2, C_4)$ -free graphs	$\omega(G) + 1$	[9, 81, 129]
$(2P_2, \text{paw})$ -free graphs	$\max\{3, \omega(G)\}$	[63, 136]
$(2P_2, K_4 - e)$ -free graphs	$\max\{3, \omega(G)\}$	[74]
$(2P_2, \overline{P_2 + P_3})$ -free graphs	$\omega(G) + 1$	[104]
$(3K_1, C_4)$ -free graphs	$\lceil \frac{5}{4}\omega(G) \rceil$	[34]
$(3K_1, \text{paw})$ -free graphs	$\max\{3, \omega(G)\}$	[63, 136]
$(3K_1, K_4 - e)$ -free graphs	$\max\{3, \omega(G)\}$	[74]
$(3K_1, \overline{P_2 + P_3})$ -free graphs	$2\omega(G)$	[33]
$(P_2 + P_3, C_4)$ -free graphs	$\lceil \frac{5}{4}\omega(G) \rceil$	[31]
$(P_2 + P_3, \text{paw})$ -free graphs	$\max\{4, \omega(G)\}$	[136, 145]
$(P_2 + P_3, K_4 - e)$ -free graphs	$\max\{6, \omega(G)\}$	[76, 105]

Table 3: Known chromatic bounds for some subclasses of $(P_2 + P_3, \overline{P_2 + P_3})$ -free graphs.

Chapter 3

Coloring $(P_5, 4\text{-wheel})$ -free graphs

3.1 Introduction

In this chapter¹, we are interested in finding the tight chromatic bound for the class of $(P_5, 4\text{-wheel})$ -free graphs. The class of $(P_5, 4\text{-wheel})$ -free graphs generalizes the class of: $(2P_2, 4\text{-wheel})$ -free graphs, $(3K_1, 4\text{-wheel})$ -free graphs, (P_5, C_4) -free graphs, and $(P_5, K_4 - e)$ -free graphs. Recall that every (P_5, C_4) -free graph [32] H satisfies $\chi(H) \leq \lceil \frac{5}{4}\omega(H) \rceil$. Choudum, Karthick and Shalu [32] studied the class of $(P_5, 4\text{-wheel})$ -free graphs, and showed a decomposition theorem for such a class of graphs. As a corollary of that result they proved a linear χ -binding function for the class of $(P_5, 4\text{-wheel})$ -free graphs. Indeed, they showed the following:

Theorem E ([32]) *Let G be a connected $(P_5, 4\text{-wheel})$ -free graph. Then the vertex-set of G can be partitioned into two sets, say V_1 and V_2 , such that*

(i) $G[V_1]$ contains a dominating- C_4 .

(ii) $G[V_2]$ is (P_5, C_4) -free.

Corollary F ([32]) *If G is a $(P_5, 4\text{-wheel})$ -free graph, then $\chi(G) \leq 5 \lceil \frac{5}{4}\omega(G) \rceil$.*

The bound given in Corollary F is clearly not tight. Recall that a graph G is nice if it has three pairwise disjoint stable sets, say S_1, S_2 and S_3 , such that $\omega(G - (S_1 \cup S_2 \cup S_3)) \leq \omega(G) - 2$. Here, we explore the structure of $(P_5, 4\text{-wheel})$ -free graphs in detail and prove that if G is a connected $(P_5, 4\text{-wheel})$ -free graph which has no clique cut-set, then either G is a perfect graph, or G is a quasi-line graph, or G is a nice graph. As a consequence of this result, we prove that every $(P_5, 4\text{-wheel})$ -free graph G satisfies $\chi(G) \leq \frac{3}{2}\omega(G)$. We also provide infinitely many $(P_5, 4\text{-wheel})$ -free graphs H with $\chi(H) \geq \frac{10}{7}\omega(H)$.

The remainder of this chapter is organized as follows. In Section 3.2, we give some preliminaries. In Section 3.3, we present some useful structural properties of $(P_5, 4\text{-wheel})$ -free graphs that contain a C_5 , and in Section 3.4, we prove our main structural decomposition theorem. Finally, in Section 3.5 we prove our chromatic bound for the class of $(P_5, 4\text{-wheel})$ -free graphs.

¹The results of this chapter are appearing in “A. Char and T. Karthick. *Coloring of $(P_5, 4\text{-wheel})$ -free graphs*. **Discrete Mathematics** (345) 2022. Article no.: 112795. <https://doi.org/10.1016/j.disc.2022.112795>”

3.2 Some preliminaries

We say an index $i \in [k]$, if $i \in \{1, 2, \dots, k\}$, i modulo k .

For a vertex subset U of G , let R_U denote a maximum stable set of U , if $U \neq \emptyset$, otherwise let $R_U := \emptyset$.

Let G be any graph. Suppose X is a subset of $V(G)$ that induces a P_3 -free graph in G . Then:

- Each component of $G[X]$ is a complete subgraph of G , and so the set X can be written as a disjoint union of (non-empty) cliques; each such clique is a maximal clique of $G[X]$ and we refer to ‘ X -clique’.
- We say that a set $S \subseteq V(G) \setminus X$ is *complete to exactly one X -clique*, if there is an X -clique, say K , such that S is complete to K , and S is anticomplete to $X \setminus K$.
- Let $v \in V(G) \setminus X$ be any vertex. We say that the vertex v is *good with respect to X* if it satisfy the following two conditions: (a) If v has a neighbor in an X -clique, say K , then $\{v\}$ is complete to K , and (b) $\{v\}$ is complete to at least one X -clique.

We use the following simple observations often.

Observation 1 *Let G be any P_5 -free graph. Let A , B_1 and B_2 be three non-empty, pairwise disjoint and mutually anticomplete subsets of $V(G)$. Let x and y be two non-adjacent vertices in $V(G) \setminus (A \cup B_1 \cup B_2)$ such that x and y have a common neighbor in A , x has a neighbor in B_1 , and y has a neighbor in B_2 . Then x and y must have a common neighbor either in B_1 or in B_2 .*

Observation 2 *Let G be any 4-wheel-free graph, and let S be a subset of $V(G)$. If there are non-adjacent vertices, say u and v in $V(G) \setminus S$ such that $\{u, v\}$ is complete to S , then S induces a P_3 -free graph.*

Observation 3 *Let G be any graph. Let D_1 , D_2 and D_3 be three disjoint non-empty subsets of $V(G)$ such that each induces a P_3 -free graph. Suppose that each D_i -clique is either complete or anticomplete to a D_j -clique, where $i, j \in \{1, 2, 3\}$ and $i \neq j$. If M is a maximal clique in G containing vertices from both D_1 and D_2 , then $R_{D_1} \cup R_{D_2}$ meets M twice.*

Proof. If $M \cap D_3 = \emptyset$, then clearly the assertion holds. So we may assume that $M \cap D_3 \neq \emptyset$. Then by our assumption, M is of the form $\bigcup_{i=1}^3 D_i^*$, where D_i^* is a D_i -clique. Since R_{D_1} contains a vertex from D_1^* , and R_{D_2} contains a vertex from D_2^* , we conclude that $R_{D_1} \cup R_{D_2}$ meets M twice. This proves Observation 3. □

Next we prove a structure theorem for a subclass of $(P_5, 4\text{-wheel})$ -free graphs, namely the class of $(3K_1, 4\text{-wheel})$ -free graphs, and use it later.

Lemma 3.1 *If G is a $(3K_1, 4\text{-wheel})$ -free graph, then G is either a quasi-line graph or a nice graph.*

Proof. Let G be a $(3K_1, 4\text{-wheel})$ -free graph, and let $v \in V(G)$ be arbitrary. First suppose that $G[N(v)]$ is chordal. Since the complement graph of a $3K_1$ -free chordal graph is a $(K_3, 2P_2, C_5)$ -free graph (which is a bipartite graph), we see that $N(v)$ can be expressed as a union of two cliques. Hence G is a quasi-line graph, since v is arbitrary. So we may assume that $G[N(v)]$ is not chordal. Then since G does not contain a 4-wheel, $G[N(v)]$ contains a C_k for some $k \geq 5$. Since, for $k \geq 6$, C_k contains a $3K_1$, $G[N(v)]$ contains a C_5 , say C . Hence G contains a 5-wheel, induced by the vertices $V(C) \cup \{v\}$. Then it is shown in [33] that G is a clique expansion of a 5-wheel. More precisely, $V(G)$ can be partitioned into six non-empty cliques, say A_1, A_2, \dots, A_5 and B such that for each $i \in \{1, 2, \dots, 5\}$, $i \bmod 5$, A_i is complete to $A_{i+1} \cup A_{i-1} \cup B$ and is anticomplete to $A_{i+2} \cup A_{i-2}$. Now we define $S_1 := R_{A_1} \cup R_{A_3}$, $S_2 := R_{A_2} \cup R_{A_4}$ and $S_3 := R_{A_5}$. Then clearly S_1, S_2 and S_3 are three stable sets in G such that $\omega(G - (S_1 \cup S_2 \cup S_3)) \leq \omega(G) - 2$, and so G is nice. This proves Lemma 3.1. \square

We will also use the following lemma proved by Karthick and Maffray [102].

Lemma 3.2 ([102]) *Let G be any graph. Let A and B be two disjoint cliques such that $G[A \cup B]$ is C_4 -free. If every vertex in A has a neighbor in B , then some vertex in B is complete to A .*

Recall that a graph G is a quasi-line graph if for any vertex v , $N(v)$ can be expressed as a union of two cliques. Chudnovsky and Seymour [45] proved a structure theorem for the class of quasi-line graphs. Using this structural result, Chudnovsky and Ovetsky [40] showed the following.

Theorem G ([40]) *Every quasi-line graph G satisfies $\chi(G) \leq \frac{3}{2}\omega(G)$.*

While proving our structural decomposition theorem, we have several intermediate graphs; we give sketches of them (in most cases) for reader's convenience, and we use the following representations: The shapes (circles or ovals) represent a collection of sets into which the vertex-set of the graph is partitioned. The sets inside an oval form a partition of that set. Each shaded shape represents a non-empty clique, and other shapes induce a P_3 -free subgraph. A solid line between any two shapes represents that the respective sets are complete to each other. A dashed line between any two shapes represents that the adjacency between these sets are arbitrary, but are restricted with some conditions. The absence of a line between any two shapes represents that the respective sets are anticomplete to each other.

3.3 Structural properties of $(P_5, 4\text{-wheel})$ -free atoms that contain a C_5

In this section, we present some important and useful structural properties of $(P_5, 4\text{-wheel})$ -free atoms which contain a C_5 , and use them in Section 3.4. Let G be a connected $(P_5, 4\text{-wheel})$ -free atom. Suppose that G contains a C_5 with vertex-set $\{v_1, v_2, v_3, v_4, v_5\}$ and the edge-set

$\{v_1v_2, v_2v_3, v_3v_4, v_4v_5, v_5v_1\}$. Then we may assume that there are five non-empty and pairwise disjoint sets A_1, A_2, \dots, A_5 such that for each i modulo 5 the set A_i is complete to $A_{i-1} \cup A_{i+1}$ and anticomplete to $A_{i-2} \cup A_{i+2}$ and let $v_i \in A_i$. Let $A := A_1 \cup \dots \cup A_5$. We choose these sets such that A is maximal. From now on, in Section 3.3, every subscript is understood modulo 5. For $i \in [5]$ we let:

$$\begin{aligned} X_i &:= \{x \in V(G) \setminus A \mid \forall j \in \{i, i+2, i-2\}, N(x) \cap A_j \neq \emptyset \text{ and } N(x) \cap (A_{i-1} \cup A_{i+1}) = \emptyset\}, \\ Y_i &:= \{x \in V(G) \setminus A \mid \forall j \in [5] \text{ and } j \neq i, N(x) \cap A_j \neq \emptyset \text{ and } N(x) \cap A_i = \emptyset\}, \\ Z &:= \{x \in V(G) \setminus A \mid \forall j \in [5], N(x) \cap A_j \neq \emptyset\}, \text{ and} \\ T &:= \{x \in V(G) \setminus A \mid N(x) \cap A = \emptyset\}. \end{aligned}$$

Let $X := X_1 \cup \dots \cup X_5$ and $Y := Y_1 \cup \dots \cup Y_5$. Then we immediately have the following:

Lemma 3.3 $V(G) = A \cup X \cup Y \cup Z \cup T$.

Proof. Suppose to the contrary that there is a vertex, say $p \in V(G) \setminus (A \cup X \cup Y \cup Z \cup T)$. Since $p \notin T$, p has a neighbor in A . Then since $p \notin X \cup Y \cup Z$, up to symmetry, we have two cases.

- (1) Suppose p has a neighbor $a_i \in A_i$, and anticomplete to $A_{i-1} \cup A_{i-2} \cup A_{i+2}$. Then $\{p, a_i, v_{i-1}, v_{i-2}, v_{i+2}\}$ induces a P_5 , a contradiction.
- (2) Suppose p has neighbors $a_{i-1} \in A_{i-1}$ and $a_{i+1} \in A_{i+1}$, and anticomplete to $A_{i-2} \cup A_{i+2}$. Then $\{p\}$ is complete to A_{i-1} for otherwise for any non-neighbor of p in A_{i-1} , say b_{i-1} , $\{b_{i-1}, v_{i-2}, v_{i+2}, a_{i+1}, p\}$ induces a P_5 , a contradiction. Likewise, $\{p\}$ is complete to A_{i+1} . But then p can be added to A_i contradicting the maximality of A .

The above contradictions show that Lemma 3.3 holds. \square

Moreover, we observe that our graph G has several interesting properties which we give in Lemmas 3.4 to 3.11 below:

Lemma 3.4 *The following hold, for each i :*

- (i) $G[A_i]$ is P_3 -free. So $G[A]$ is a P_3 -free expansion of a C_5 .
- (ii) X_i is complete to A_i .
- (iii) If K is an A_{i+2} -clique (or an A_{i-2} -clique), then any $x \in X_i$ which has a neighbor in K is complete to K . In particular, if A_{i+2} is a clique, then X_i is complete to A_{i+2} . Likewise, if A_{i-2} is a clique, then X_i is complete to A_{i-2} .
- (iv) Each vertex in X_i is good with respect to A_{i+2} , and A_{i-2} .
- (v) Each vertex in X_i is complete to either A_{i+2} or A_{i-2} .

Proof. (i): If $G[A_i]$ contains a P_3 with the vertex-set, say $\{u_1, u_2, u_3\}$, then $\{u_1, v_{i+1}, u_3, v_{i-1}, u_2\}$ induces a 4-wheel, a contradiction. So Lemma 3.4:(i) holds. \blacksquare

(ii): If there are non-adjacent vertices, say $x \in X_i$ and $p \in A_i$, then for any neighbor of x in A_{i+2} , say a_{i+2} , we see that $\{v_{i-1}, p, v_{i+1}, a_{i+2}, x\}$ induces a P_5 So Lemma 3.4:(ii) holds. \blacksquare

(iii): By symmetry, it is enough to prove the assertion for A_{i+2} . If there is a vertex in X_i , say x such that $\{x\}$ is not complete to K , then by our assumption, there are vertices, say a, b in K such that $ab, ax \in E(G)$ and $bx \notin E(G)$. But then by Lemma 3.4:(ii), $\{b, a, x, v_i, v_{i-1}\}$ induces a P_5 , a contradiction. So $\{x\}$ is complete to K . This proves Lemma 3.4:(iii). ■

(iv): The proof of Lemma 3.4:(iv) follows from the definition of X_i , Lemma 3.4:(i) and Lemma 3.4:(iii). ■

(v): Let $x \in X_i$, and suppose that the assertion is not true. Then there are vertices, say $p \in A_{i+2}$ and $q \in A_{i-2}$ such that $\{x\}$ is anticomplete to $\{p, q\}$. By the definition of X_i , x has a neighbor in A_{i+2} , say r . Then by Lemma 3.4:(i) and Lemma 3.4:(iii), $pr \notin E(G)$. But then by Lemma 3.4:(ii), $\{p, q, r, x, v_i\}$ induces a P_5 , a contradiction. So Lemma 3.4:(v) holds. □

Lemma 3.5 *The following hold, for each i :*

(i) *Any two non-adjacent vertices in X_i have a common neighbor in both A_{i+2} and A_{i-2} .*

(ii) *If X_i has two non-adjacent vertices which are complete to $A_{i+2} \cup A_{i-2}$, then $A_{i+2} \cup A_{i-2}$ is a clique.*

(iii) *If some $x \in X_i$ has a neighbor in T , then $\{x\}$ is complete to $A_{i-2} \cup A_{i+2}$.*

(iv) *$G[X_i]$ is P_3 -free.*

(v) *X_i is complete to $X_{i+1} \cup X_{i-1}$.*

Proof. (i): The proof of Lemma 3.5:(i) follows from the definition of X_i , Lemma 3.4:(i) to Lemma 3.4:(iii), and by Observation 1. ■

(ii): Suppose there are non-adjacent vertices in A_{i+2} , say a and a' . Let x and x' be two non-adjacent vertices in X_i which are complete to $A_{i+2} \cup A_{i-2}$. Then for any $a'' \in A_{i-2}$, $\{x, a, x', a', a''\}$ induces a 4-wheel, a contradiction. So A_{i+2} is a clique. Likewise, A_{i-2} is a clique. This proves Lemma 3.5:(ii). ■

(iii): Let $t \in T$ be a neighbor of x . By Lemma 3.4:(ii) and Lemma 3.4:(v), we may assume that $\{x\}$ is complete to $A_i \cup A_{i-2}$. If x has a non-neighbor in A_{i+2} , say p , then $\{p, v_{i+1}, v_i, x, t\}$ induces a P_5 , a contradiction. So $\{x\}$ is complete to A_{i+2} . This proves Lemma 3.5:(iii). ■

(iv): Suppose to the contrary that $G[X_i]$ induces a P_3 with vertex-set, say $\{a_1, a_2, a_3\}$. Then by Lemma 3.4:(v) and by the pigeonhole principle, we may assume that $\{a_1, a_2\}$ is complete to A_{i-2} . Also by the definition of X_i , a_3 has a neighbor in A_{i-2} , say p . Then by Lemma 3.4:(ii), $\{v_i, a_1, a_2, a_3, p\}$ induces a 4-wheel, a contradiction. This proves Lemma 3.5:(iv). ■

(v): Let $x \in X_i$ and $x' \in X_{i+1}$, and suppose that x and x' are non-adjacent. Using the definition of X_i , pick a neighbor of x' in A_{i-1} , say p , and a neighbor of x in A_{i+2} , say q . Then by Lemma 3.4:(ii), $\{p, x', v_{i+1}, q, x\}$ induces a P_5 , a contradiction. So X_i is complete to X_{i+1} . Likewise, X_i is complete to X_{i-1} . This proves Lemma 3.5:(v). □

Lemma 3.6 *Let K be an X_i -clique.*

(i) *Suppose that there is a vertex, say $x \in X_{i+2}$ which is anticomplete to K , and Q is an A_{i-2} -clique such that $N(K) \cap Q \neq \emptyset$. Then K is complete to Q .*

(ii) Suppose that there is a vertex, say $x \in X_{i-2}$ which is anticomplete to K , and Q' is an A_{i+2} -clique such that $N(K) \cap Q' \neq \emptyset$. Then K is complete to Q' .

Proof. We prove Lemma 3.6:(i), and the proof of Lemma 3.6:(ii) is similar. Suppose that the assertion is not true. Then there are vertices, say $p \in K$ and $r \in Q$ such that $pr \notin E(G)$. By assumption, there is a vertex, say $q \in K$ such that q has a neighbor in Q , and hence by Lemma 3.4:(iii), $qr \in E(G)$. Then for any neighbor of x in A_{i-1} , say a , we see that $\{p, q, r, a, x\}$ induces a P_5 , a contradiction. So Lemma 3.6:(i) holds. \square

Lemma 3.7 *Suppose K is an X_i -clique and K' is an X_{i+2} -clique such that K is complete to K' . Then the following hold:*

- (i) K is anticomplete to $X_{i+2} \setminus K'$ (likewise, K' is anticomplete to $X_i \setminus K$), and $X_i \setminus K$ is anticomplete to $X_{i+2} \setminus K'$.
- (ii) K is complete to exactly one A_{i+2} -clique. Likewise, K' is complete to exactly one A_i -clique.
- (iii) K is anticomplete to X_{i-2} . Likewise, K' is anticomplete to X_{i-1} .

Proof. (i): Suppose to the contrary that K is not anticomplete to $X_{i+2} \setminus K'$. Then there are vertices, say $u \in K$, $v \in K'$ and $w \in X_{i+2} \setminus K'$ such that $uv, uw \in E(G)$ and $vw \notin E(G)$. Then by Lemma 3.5:(i), v and w have a common neighbor in A_i , say p . But then for any neighbor of u in A_{i+2} , say q , by Lemma 3.4:(ii), $\{p, v, q, w, u\}$ induces a 4-wheel, a contradiction. So K is anticomplete to $X_{i+2} \setminus K'$. Likewise, K' is anticomplete to $X_i \setminus K$. This proves the first assertion of Lemma 3.7:(i).

To prove the second assertion of Lemma 3.7:(i), suppose there are adjacent vertices, say $u' \in X_i \setminus K$ and $v' \in X_{i+2} \setminus K'$. Then for any $v \in K'$, since $vv' \notin E(G)$, by Lemma 3.5:(i), v and v' have a common neighbor in A_{i-1} , say p . But then for any $u \in K$, by using the first assertion of Lemma 3.7:(i), we see that $\{u, v, p, v', u'\}$ induces a P_5 , a contradiction. This proves the second assertion of Lemma 3.7:(i). \blacksquare

(ii): First we show that each vertex in K is complete to exactly one A_{i+2} -clique. Suppose not. Then by Lemma 3.4:(iv), there are vertices, say $p \in K$ and $a, a' \in A_{i+2}$ such that $pa, pa' \in E(G)$ and $aa' \notin E(G)$. But then for any $q \in K'$, and for any neighbor of p in A_{i-2} , say r , by Lemma 3.4:(ii), $\{r, a, q, a', p\}$ induces a 4-wheel, a contradiction. So each vertex in K is complete to exactly one A_{i+2} -clique. Now we show that K is complete to exactly one A_{i+2} -clique. Suppose not. Then by Lemma 3.4:(iii) and by the earlier argument, there are vertices, say $u, v \in K$ and $p \in A_{i+2}$ such that $up \in E(G)$ and $vp \notin E(G)$. Then by Lemma 3.4:(v), $\{v\}$ is complete to A_{i-2} . But then for any neighbor of u in A_{i-2} , say a , and for any $q \in K'$, by Lemma 3.4:(ii), $\{a, v, q, p, u\}$ induces a 4-wheel, contradiction. So Lemma 3.7:(ii) holds. \blacksquare

(iii): Let $u \in K$ and $v \in X_{i-2}$, and suppose u and v are adjacent. Let $r \in K'$. By Lemma 3.5:(v), v and r are adjacent. Now pick any neighbor of u in A_{i+2} , say p , and in A_{i-2} , say q . Then by Lemma 3.4:(ii), $\{p, q, v, r, u\}$ induces a 4-wheel, a contradiction. So Lemma 3.7:(iii) holds. \square

Lemma 3.8 *Let K be an X_i -clique and K' be an X_{i-1} -clique. If Q is an A_{i+2} -clique such that $N(K) \cap Q \neq \emptyset$ and $N(K') \cap Q \neq \emptyset$, then $K \cup K'$ is complete to Q .*

Proof. We prove the assertion for $i = 1$. Suppose that K is not complete to Q . Then there are vertices $p \in K$ and $r \in Q$ such that $pr \notin E(G)$. By assumption, there is a vertex, say $q \in K$ such that q has a neighbor in Q , and so by Lemma 3.4:(iii), $qr \in E(G)$. Also by our assumption, there is a vertex, say $w \in K'$ such that w has a neighbor in Q , and again by Lemma 3.4:(iii), $wr \in E(G)$. Since $\{p\}$ is not complete to A_3 , $\{p\}$ is complete to A_4 , and so p and q share a common neighbor in A_4 , say x . Then since X_1 is complete to X_5 (by Lemma 3.5:(v)), we see that $\{w, r, x, p, q\}$ induces a 4-wheel, a contradiction. So K is complete to Q . Likewise, K' is complete to Q . This proves Lemma 3.8. \square

For each $i \in [5]$, if $X_i \neq \emptyset$, let \mathbb{W}_i be the set $\{X^* \cup A^* \mid X^* \text{ is an } X_i\text{-clique and } A^* \text{ is an } A_i\text{-clique such that } |X^* \cup A^*| = \omega(G)\}$, otherwise let $\mathbb{W}_i := \emptyset$. Next we have the following:

Lemma 3.9 *Let K be an X_i -clique and K' be an X_{i+1} -clique, and let A_i^* be an A_i -clique and A_{i+1}^* be an A_{i+1} -clique. Suppose that $K \cup A_i^* \in \mathbb{W}_i$ and $K' \cup A_{i+1}^* \in \mathbb{W}_{i+1}$. Then for any A_{i+2} -clique D_{i-2} , $K \cup K' \cup D_{i-2}$ is not a clique.*

Proof. By Lemma 3.5:(v), $K \cup K'$ is a clique. Suppose there is an A_{i-2} -clique, say D , such that $K \cup K' \cup D$ is a clique. Let $q := \omega(G)$. Then $|K \cup K'| < q$ (since $D \neq \emptyset$). Then since $|K \cup A_i^*| + |K' \cup A_{i+1}^*| = 2q$, we have $2q = |A_i^* \cup A_{i+1}^*| + |K \cup K'| < |A_i^* \cup A_{i+1}^*| + q$, and hence $|A_i^* \cup A_{i+1}^*| > q$, which is a contradiction to the fact that $A_i^* \cup A_{i+1}^*$ is a clique. This proves Lemma 3.9. \square

Lemma 3.10 *The following hold, for each i :*

- (i) *Let Q be the vertex-set of a component of $G[T]$. Then each vertex in X_i is either complete or anticomplete to Q .*
- (ii) *For $j \in \{i-1, i+1\}$, if A_j is not a clique, then Y_i is complete to A_j .*
- (iii) *Each vertex in Y_i is complete to either A_{i-1} or A_{i+1} .*
- (iv) *Let Q be the vertex-set of a component of $G[T]$. Then each vertex in Y_i is either complete or anticomplete to Q .*
- (v) *If $Z = \emptyset$, then $G[T]$ is P_3 -free.*

Proof. (i): Otherwise, there are adjacent vertices, say q, q' in Q , and a vertex $x \in X_i$ such that $xq \in E(G)$ and $xq' \notin E(G)$; but then by Lemma 3.4:(ii), $\{q', q, x, v_i, v_{i-1}\}$ induces a P_5 , a contradiction. So Lemma 3.10:(i) holds. \blacksquare

(ii): We may assume, up to symmetry, that $j = i + 1$. Let $y \in Y_i$. Then by the definition of Y_i , y has a neighbor in A_{i+1} , say p . Let K be the A_{i+1} -clique containing p . Since A_{i+1} is not a clique, $A_{i+1} \setminus K \neq \emptyset$. Now if y is non-adjacent to some $q \in A_{i+1} \setminus K$ (say), then for any neighbor of y in A_{i-2} , say r , we see that $\{q, v_i, p, y, r\}$ induces a P_5 , a contradiction; so $\{y\}$ is complete to

$A_{i+1} \setminus K$. By the same argument, since $A_{i+1} \setminus K$ is non-empty, $\{y\}$ is complete to K . This proves Lemma 3.10:(ii), since y is arbitrary. ■

(iii): Let $y \in Y_i$. Suppose y has a non-neighbor in each A_{i-1} and A_{i+1} , say a and a' respectively. So by Lemma 3.10:(ii), A_{i-1} and A_{i+1} are cliques. Now by the definition of Y_i , pick any neighbor of y in each A_{i-1} and A_{i+1} , say b and b' respectively. Then $\{a, b, y, b', a'\}$ induces a P_5 , a contradiction. So Lemma 3.10:(iii) holds. ■

(iv): Otherwise, there are adjacent vertices, say q and q' in Q , and a vertex, say $y \in Y_i$ such that $yq \in E(G)$ and $yyq' \notin E(G)$; but then for any neighbor of y in A_{i+1} , say a , we see that $\{q', q, y, a, v_i\}$ induces a P_5 , a contradiction. So Lemma 3.10:(iv) holds. ■

(v): Suppose that there is a component of $G[T]$ which has an induced P_3 with the vertex-set, say $\{t_1, t_2, t_3\}$, and let Q be the vertex-set of that component. Since G is connected and since $N(Q) \cap (X \cup Y)$ is not a clique cut-set, there are non-adjacent vertices in $N(Q) \cap (X \cup Y)$, say u and v . Then by Lemma 3.10:(i) and Lemma 3.10:(iv), $\{u, v\}$ is complete to Q ; but then $\{u, t_1, v, t_3, t_2\}$ induces a 4-wheel, a contradiction. So Lemma 3.10:(v) holds. □

So if $Z = \emptyset$, then, by Lemma 3.10:(i), Lemma 3.10:(iv) and Lemma 3.10:(v), each vertex in $X \cup Y$ is either anticomplete to T or good with respect to T .

Lemma 3.11 *Suppose there are vertices, say $t \in T$, $u \in X_i$ and $v \in X_{i-2} \cup X_{i+2} \cup Y_i \cup Y_{i+1} \cup Y_{i-1} \cup Z$ such that $ut \in E(G)$ and $uv \notin E(G)$. Let K be the X_i -clique containing u . Then the following hold:*

(i) t is adjacent to v .

(ii) If $\{v\}$ is anticomplete to K , then $\{t\}$ is complete to K . Moreover, if T^* is the component of T containing t , then T^* is complete to K .

Proof. First note that v has a neighbor in one of A_{i-1} , A_{i+1} . We may assume, up to symmetry, that v has a neighbor in A_{i-1} , say p . So $v \notin X_{i-2} \cup Y_{i-1}$.

(i): Suppose t is non-adjacent to v . If v is non-adjacent to some vertex in A_i , say q , then, by Lemma 3.4:(ii), $\{v, p, q, u, t\}$ induces a P_5 , a contradiction; so $\{v\}$ is complete to A_i . Thus $v \notin Y_i$, and so $v \in X_{i+2} \cup Y_{i+1} \cup Z$. Then since $ut \in E(G)$, by Lemma 3.5:(iii), $\{u\}$ is complete to A_{i+2} , and so u and v have a common neighbor in A_{i+2} , say r . But then $\{t, u, r, v, p\}$ induces a P_5 , a contradiction. So Lemma 3.11:(i) holds. ■

(ii): If there is a vertex, say $u' \in K$ such that $u't \notin E(G)$, then by Lemma 3.11:(i), $\{u', u, t, v, p\}$ induces a P_5 , a contradiction. So the first assertion of Lemma 3.11:(ii) holds. The second assertion of Lemma 3.11:(i) follows from Lemma 3.10:(i). □

3.4 Structure of $(P_5, 4\text{-wheel})$ -free atoms

While proving our structure decomposition theorem, in most cases we show that our graph G is nice, and to do the same it is enough to find three stable sets S_1, S_2 , and S_3 such that $S_1 \cup S_2 \cup S_3$ meets each maximum clique of G at least twice, and meet other maximal cliques of G at least once.

3.4.1 Structure of $(P_5, 4\text{-wheel})$ -free atoms that contain a 5-wheel

Let G be a connected $(P_5, 4\text{-wheel})$ -free atom which contains a 5-wheel, say with the 5-cycle with vertex-set $\{v_1, v_2, v_3, v_4, v_5\}$ and the edge-set $\{v_1v_2, v_2v_3, v_3v_4, v_4v_5, v_5v_1\}$ plus a vertex z^* that is adjacent to v_i , for all $i \in [5]$. Then we define the sets A, X, Y, Z and T as in Section 3.3 with $v_i \in A_i$ for each $i \in [5]$, and we use the lemmas in Section 3.3. Note that $z^* \in Z$. Moreover, the graph G has some more structural properties, and are given in Lemmas 3.12 to 3.14 below.

Lemma 3.12 *The following hold, for each i :*

- (i) *Let K be an A_i -clique. If a vertex in Z has a neighbor in K , then it is complete to K and anticomplete to $A_i \setminus K$. More precisely, each vertex in Z is complete to exactly one A_i -clique.*
- (ii) *There is an index $j \in [5]$ such that A_j, A_{j-2} and A_{j+2} are cliques.*
- (iii) *Z is a clique.*
- (iv) *There is an A_i -clique, say A_i^* , such that Z is complete to A_i^* and anticomplete to $A_i \setminus A_i^*$.*
- (v) *$R_{A_{i+2}} \cup R_{A_{i-2}}$ meets each maximal clique of G in $G[Z \cup A_{i+2} \cup A_{i-2}]$ twice.*

Proof. (i): Let $z \in Z$, and suppose z has a neighbor in K , say p . Pick a neighbor of z in each A_{i+1} and A_{i-1} , say a and a' respectively. If there is a vertex, say $q \in K$ which is non-adjacent to z , then since K is a clique, $pq \in E(G)$, and then $\{a, z, a', q, p\}$ induces a 4-wheel, a contradiction; so $\{z\}$ is complete to K . Next if there is a vertex, say $r \in A_i \setminus K$ which is adjacent to z , then clearly $pr \notin E(G)$, and then $\{p, a, r, a', z\}$ induces a 4-wheel, a contradiction; so $\{z\}$ is anticomplete to $A_i \setminus K$. This proves Lemma 3.12:(i). ■

(ii): We first show that, for $i \in [5]$, each vertex in Z is complete to either A_i or A_{i+1} . Suppose not. Then there are vertices, say $b \in A_i$ and $b' \in A_{i+1}$ such that $zb, zb' \notin E(G)$. Now pick a neighbor of z in each A_i and A_{i-2} , say a and a' , respectively. Then by Lemma 3.12:(i), $ab \notin E(G)$; but then $\{b, b', a, z, a'\}$ induces a P_5 , a contradiction. So each vertex in Z is complete to either A_i or A_{i+1} . Then for $i \in [5]$, since $z^* \in Z$ is complete to exactly one A_i -clique (by Lemma 3.12:(i)), we see that either A_i or A_{i+1} is a clique, and so Lemma 3.12:(ii) holds. ■

(iii): Suppose there are non-adjacent vertices, say z_1 and z_2 in Z . Then by Lemma 3.12:(ii), we may assume that A_1 and A_3 are cliques. So by Lemma 3.12:(i), $\{z_1, z_2\}$ is complete to $A_1 \cup A_3$. Also, by the definition of Z , Observation 1 and by Lemma 3.12:(i), it follows that z_1 and z_2 have a common neighbor in A_2 , say p . Then $\{v_1, z_1, v_3, z_2, p\}$ induces a 4-wheel, a contradiction. So Lemma 3.12:(iii) holds. ■

(iv): By Lemma 3.12:(ii), we may assume that A_1, A_3 and A_4 are cliques. So by Lemma 3.12:(i), for $j \in \{1, 3, 4\}$, A_j is our required A_j^* . This implies that Z is complete to A_j , for $j \in \{1, 3, 4\}$. Next we prove that A_2^* and A_5^* exist. Suppose, up to symmetry, A_2^* does not exist. Then by Lemma 3.12:(i), there are vertices, say $z_1, z_2 \in Z$, and a vertex, say $p \in A_2$ such that $z_1p \in E(G)$ and $z_2p \notin E(G)$. By Lemma 3.12:(iii), $z_1z_2 \in E(G)$. Then $\{v_1, p, v_3, z_2, z_1\}$ induces a 4-wheel, a contradiction. So A_2^* exists. So Lemma 3.12:(iv) holds. ■

(v): The proof follows from Lemma 3.4:(i), Lemma 3.12:(iii) and Lemma 3.12:(iv). □

Throughout this subsection, for $i \in [5]$, A_i^* is an A_i -clique as in Lemma 3.12:(iv). Note that by Lemma 3.12:(iv), since $z^* \in Z$ and $v_i \in A_i^*$, we see that Z is complete to $\{v_1, v_2, \dots, v_5\}$, and if A_i is a clique, then $A_i = A_i^*$ and Z is complete to A_i .

Lemma 3.13 *The following hold, for each i :*

(i) X_i is anticomplete to Z .

(ii) For $j \in \{i-2, i+2\}$, X_i is complete to A_j^* , and anticomplete to $A_j \setminus A_j^*$.

(iii) $R_{A_{i+2}} \cup R_{A_{i-2}}$ meets each maximum clique of G in $G[X_i \cup A_{i+2} \cup A_{i-2}]$ twice.

(iv) X_i is anticomplete to $X_{i+2} \cup X_{i-2}$.

(v) Y is empty.

(vi) If a vertex in X_i has a neighbor in T , then A_{i-2} and A_{i+2} are cliques.

Proof. (i): Let $x \in X_i$ and $z \in Z$, and suppose x and z are adjacent. By Lemma 3.4:(ii) and Lemma 3.4:(v), we may assume that $\{x\}$ is complete to $A_i \cup A_{i+2}$. Then $\{v_i, v_{i+1}, v_{i+2}, x, z\}$ induces a 4-wheel, a contradiction. So Lemma 3.13:(i) holds. ■

(ii): By Lemma 3.12:(ii), we may assume that A_{i-2} is a clique; so $A_{i-2} = A_{i-2}^*$. Then by Lemma 3.4:(iii), X_i is complete to A_{i-2} . Next we prove for $j = i+2$. Pick any $x \in X_i$. Then by Lemma 3.13:(i), $z^*x \notin E(G)$. Also by Lemma 3.4:(ii), x and z^* have a common neighbor in A_i . Then by our definitions of X_i and Z , Lemma 3.12:(iv), and by Observation 1, x and z^* must have a common neighbor in A_{i+2}^* , say p . So by Lemma 3.4:(iii), $\{x\}$ is complete to A_{i+2}^* . Next, if x is adjacent to some vertex in $A_{i+2} \setminus A_{i+2}^*$, say q , then $\{q, x, p, z^*, v_{i-1}\}$ induces a P_5 , a contradiction. So $\{x\}$ is anticomplete to $A_{i+2} \setminus A_{i+2}^*$. This proves Lemma 3.13:(ii), since $x \in X_i$ is arbitrary. ■

(iii): Since $R_{A_{i+2}}$ contains a vertex of A_{i+2}^* , and $R_{A_{i-2}}$ contains a vertex of A_{i-2}^* , the proof follows from Lemma 3.4:(i), Lemma 3.5:(iv), and from Lemma 3.13:(ii). ■

(iv): Let $x \in X_i$ and $x' \in X_{i+2}$, and suppose x and x' are adjacent. By Lemma 3.13:(i), z^* is non-adjacent to both x and x' , and by Lemma 3.12:(iv) and Lemma 3.13:(ii), $\{v_{i-2}\}$ is complete to $\{x, z^*\}$. But now $\{v_{i+1}, z^*, v_{i-2}, x, x'\}$ induces a P_5 , a contradiction. This proves Lemma 3.13:(iv). ■

(v): Suppose not, and let $y \in Y_i$. Then by Lemma 3.10:(ii) and Lemma 3.12:(iv), y and z^* have a common neighbor in both A_{i+1} and A_{i-1} , say p and q , respectively. If $z^*y \in E(G)$, then $\{y, q, v_i, p, z^*\}$ induces a 4-wheel, a contradiction; so we may assume that $z^*y \notin E(G)$. Then by

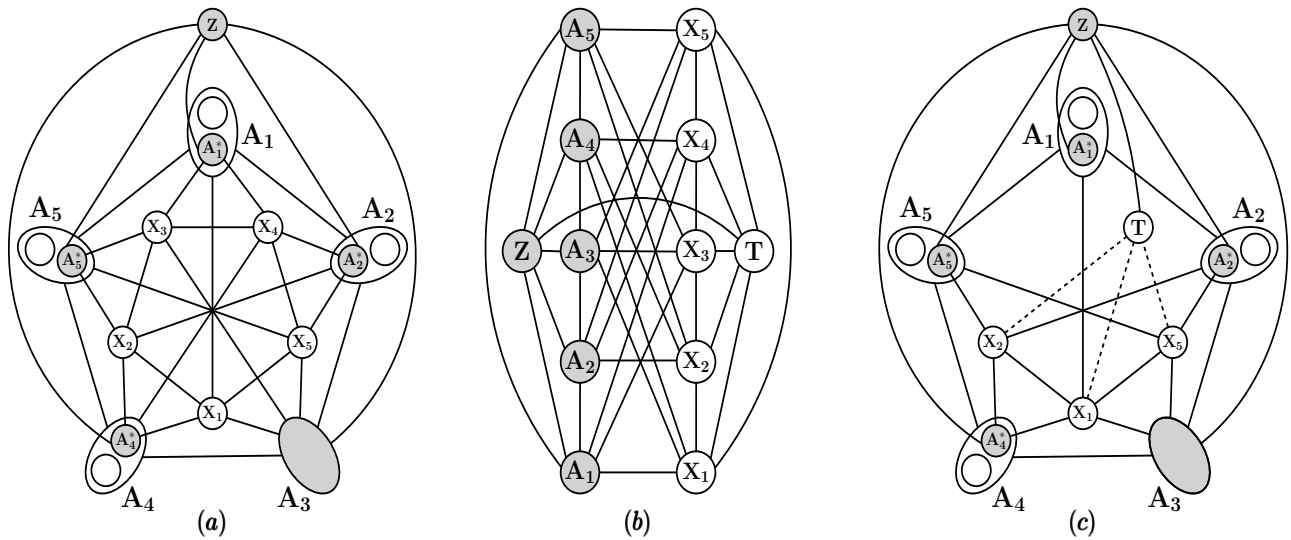

Figure 11: Sketch of the graph G in Theorem 3.15: (a) When $T = \emptyset$. (b) Case 1. (c) Case 2.

our definitions of Y_i and Z , Lemma 3.10:(ii), Lemma 3.12:(iv) and by Observation 1, z^* and y must have a common neighbor in A_{i+2}^* , say b , and in A_{i-2} , say a . Then $\{p, y, a, z^*, b\}$ induces a 4-wheel, a contradiction. So Lemma 3.13:(v) holds. ■

(vi): Let $x \in X_i$ be a vertex such that x has a neighbor in T . Then by Lemma 3.5:(iii), $\{x\}$ is complete to $A_{i-2} \cup A_{i+2}$. Now the conclusion follows from Lemma 3.13:(ii). □

Lemma 3.14 *The following hold:*

- (i) *Let Q be the vertex-set of a component of $G[T]$. Then there is an index $j \in [5]$ such that $N(Q) \cap X_j$ is non-empty, and is complete to Q . In particular, every vertex in T has a neighbor in X .*
- (ii) *Z is complete to T .*
- (iii) *$G[T]$ is P_3 -free.*

Proof. (i): We know, by Lemma 3.13:(v), that $Y = \emptyset$. Since Z is a clique (by Lemma 3.12:(iii)), and since $N(Q) \cap Z$ is not a clique cut-set, we see that $N(Q) \cap X \neq \emptyset$. So there is an index $j \in [5]$ such that $N(Q) \cap X_j \neq \emptyset$. Pick any $x \in N(Q) \cap X_j$. Then, by Lemma 3.10:(i), $\{x\}$ is complete to Q . This proves Lemma 3.14:(i). ■

(ii): Since X is anticomplete to Z (by Lemma 3.13:(i)), the proof follows from Lemma 3.14:(i) and Lemma 3.11:(i). ■

(iii): Suppose not. Let Q be the vertex-set of a component of $G[T]$. Suppose to the contrary that $G[Q]$ contains a P_3 with the vertex-set, say $\{p, q, r\}$. Then by Lemma 3.14:(i), for some $j \in [5]$, there is a vertex, say $x \in X_j$ such that $\{x\}$ is complete to Q . But then by Lemma 3.13:(i) and Lemma 3.14:(ii), $\{p, z^*, r, x, q\}$ induces a 4-wheel, a contradiction. So Lemma 3.14:(iii) holds. □

Now we give our main result of this subsection.

Theorem 3.15 *If a connected $(P_5, 4\text{-wheel})$ -free atom G contains a 5-wheel, then G is nice.*

Proof. Let G be a connected $(P_5, 4\text{-wheel})$ -free atom that contains a 5-wheel, say with the 5-cycle with vertex-set $\{v_1, v_2, v_3, v_4, v_5\}$ and the edge-set $\{v_1v_2, v_2v_3, v_3v_4, v_4v_5, v_5v_1\}$ plus a vertex z^* that is adjacent to v_i , for all $i \in [5]$. Then we define the sets A, X, Y, Z and T as in Section 3.3 with $v_i \in A_i$ for each $i \in [5]$. We use the lemmas in Section 3.3, and the properties in Lemmas 3.12 to 3.14. Let \mathcal{M} denote the set of maximum cliques in G . To prove the theorem, it is enough to find three stable sets S_1, S_2 , and S_3 such that $S_1 \cup S_2 \cup S_3$ meets each maximum clique of G at least twice, and meet other maximal cliques of G at least once. Recall that X_i is complete to $X_{i+1} \cup X_{i-1}$ (by Lemma 3.5:(v)) and anticomplete to $X_{i+2} \cup X_{i-2}$ (by Lemma 3.13:(iv)). First suppose that $T = \emptyset$. (See Figure 11:(a) for a sketch of G .) By Lemma 3.12:(ii) and up to relabeling, we may assume that A_3 is a clique. Then, by Lemma 3.9, one of $\mathbb{W}_1, \mathbb{W}_5$ is empty. We may assume that $\mathbb{W}_5 = \emptyset$, and so either $X_5 = \emptyset$ or no maximum clique of G is in $G[X_5 \cup A_5]$.

Now we let $S_1 := R_{A_1} \cup R_{A_3} \cup R_{X_2}$, $S_2 := R_{A_2} \cup R_{A_4} \cup R_{X_3}$ and $S_3 := R_{A_5} \cup R_{X_1} \cup R_{X_4}$, and let $S := S_1 \cup S_2 \cup S_3$. Clearly S_1, S_2 and S_3 are stable sets. By Lemma 3.13:(ii) and Lemma 3.13:(iii), S meets each maximal clique of G in $G[A \cup X]$ twice. Also, by Lemma 3.12:(v), S meets each maximal clique of G in $G[A \cup Z]$ twice. So, by Lemma 3.13:(i), we see that S_1, S_2 and S_3 are the required stable sets. Hence we may assume that $T \neq \emptyset$. By Lemma 3.14:(iii), we know that $G[T]$ is P_3 -free. Let L be the set that consists of one vertex from each T -clique. Let L' be the set that consists of one vertex (which is not in L) from each non-trivial T -clique; otherwise we let $L' := \emptyset$. Moreover:

3.15.1 *Let Q be a T -clique and let K be an X_i -clique. Then Q is either complete or anticomplete to K .*

Proof of 3.15.1. Since $Z \neq \emptyset$, the proof follows from Lemma 3.13:(i) and from Lemma 3.11:(ii). ■

So any maximal clique of G containing vertices from both an X_i -clique X_i^* and a T -clique T^* is $X_i^* \cup T^*$.

3.15.2 *If T^* is a T -clique such that $Z \cup T^* \in \mathcal{M}$ or $X_i^* \cup T^* \in \mathcal{M}$, where X_i^* is an X_i -clique, then $|T^*| \geq 2$.*

Proof of 3.15.2. If $Z \cup T^* \in \mathcal{M}$, then since $Z \cup A_1^* \cup A_2^*$ is a clique (by Lemma 3.12:(iii) and Lemma 3.12:(iv)), we have $|Z \cup T^*| \geq |Z \cup A_1^* \cup A_2^*|$, and thus $|T^*| \geq 2$. Now if $X_i^* \cup T^* \in \mathcal{M}$, then since $X_i^* \cup A_{i+2} \cup A_{i-2}$ is a clique (by Lemma 3.13:(ii) and Lemma 3.13:(vi)), we have $|X_i^* \cup T^*| \geq |X_i^* \cup A_{i+2} \cup A_{i-2}|$, and so $|T^*| \geq 2$. This proves 3.15.2. ■

Now we prove the theorem in two cases based on the set X .

Case 1 Suppose there is an index $j \in [5]$ such that X_j, X_{j+2} and X_{j-2} are non-empty.

Then by Lemma 3.11, Lemma 3.13:(iv) and Lemma 3.14:(i), we see that T is complete to X . So by Lemma 3.13:(vi), for each $i \in [5]$, A_i is a clique (so $A_i = A_i^*$), and so by Lemma 3.4:(iii), X_i is complete to $A_{i-2} \cup A_{i+2}$. See Figure 11:(b) for a sketch of G . First suppose that for any T -clique T^* , $Z \cup T^* \notin \mathcal{M}$. Now if $\mathbb{W}_i \neq \emptyset$, then we let $k = i$, otherwise we let $k = j$. Then since for each $i \in [5]$, A_i is a clique, by Lemma 3.9, \mathbb{W}_{k-1} and \mathbb{W}_{k+1} are empty. So we let $S_1 := R_{A_k} \cup R_{A_{k+2}} \cup R_T$, $S_2 := R_{A_{k+1}} \cup R_{A_{k-2}} \cup R_{X_{k+2}}$ and $S_3 := R_{A_{k-1}} \cup R_{X_k} \cup R_{X_{k-2}}$. Then, since $R_T \cup R_{X_k} \cup R_{X_{k+2}} \cup R_{X_{k-2}}$ meets each maximum clique of G in $G[X \cup Z \cup T]$ twice, and meets the other maximal cliques in $G[X \cup Z \cup T]$ once, by Lemma 3.12:(v) and Lemma 3.13:(iii), we see that S_1, S_2 and S_3 are the desired stable sets. So suppose that there is a T -clique T^* such that $Z \cup T^* \in \mathcal{M}$. Then, by 3.15.2, $|T^*| \geq 2$. Now for any X_i -clique X_i^* , and for any X_{i+1} -clique X_{i+1}^* , by Lemma 3.5:(v), $|Z \cup T^*| \geq |X_i^* \cup X_{i+1}^* \cup T^*|$, and thus $|Z| \geq |X_i^* \cup X_{i+1}^*|$. So the following hold:

- (a) For each $i \in [5]$, since $Z \cup A_i \cup A_{i+1}$ is a larger clique than $X_i^* \cup A_i$, we have $\mathbb{W}_i = \emptyset$.
- (b) For each $i \in [5]$, since $Z \cup A_{i+2} \cup A_{i-2}$ is a larger clique than $X_i^* \cup X_{i+1}^* \cup A_{i-2}$, we have $X_i^* \cup X_{i+1}^* \cup A_{i-2} \notin \mathcal{M}$.
- (c) If there is a T -clique T_1 such that $X_i^* \cup X_{i+1}^* \cup T_1 \in \mathcal{M}$, then since $|Z| \geq |X_i^* \cup X_{i+1}^*|$, we have $Z \cup T_1 \in \mathcal{M}$; so $|T_1| \geq 2$ (by 3.15.2).

Now, by 3.15.2 and (c), $L \cup L'$ meets each maximum clique of G in $G[X \cup Z \cup T]$ twice, and meets the other maximal cliques in $G[X \cup Z \cup T]$ once. So we let $S_1 := R_{A_1} \cup R_{A_3}$, $S_2 := R_{A_2} \cup R_{A_5} \cup L$, and $S_3 := R_{A_4} \cup L'$. Then, by (a), (b), Lemma 3.12:(v) and Lemma 3.13:(iii), we see that S_1, S_2 and S_3 are the required stable sets.

Case 2 For each $j \in [5]$, at least one of X_j, X_{j+2}, X_{j-2} is empty.

Then there is an index $i \in [5]$ such that $X_i \neq \emptyset$ and $X \setminus X_i = \emptyset$ or $X_{i-1}, X_i \cup X_{i+1} \neq \emptyset$ and $X \setminus (X_{i-1} \cup X_i \cup X_{i+1}) = \emptyset$, say $i = 1$. By Lemma 3.11, Lemma 3.13:(vi) and Lemma 3.14:(i), we may assume that A_3 is a clique. By 3.15.1, any T -clique T^* that is anticomplete to X_1 , is complete to an X_2 -clique or an X_5 -clique (or to both, if $X_2 \cup X_5 \neq \emptyset$, by Lemma 3.11); so by Lemma 3.13:(vi), A_4 is a clique (if $X_2 \neq \emptyset$), and $|T^*| \geq 2$ (by 3.15.2). See Figure 11:(c). Now if $\mathbb{W}_1 \neq \emptyset$, then by Lemma 3.9, $\mathbb{W}_2 \cup \mathbb{W}_5 = \emptyset$, and we let $S_1 := R_{A_2} \cup R_{A_5} \cup R_{X_1}$, $S_2 := R_{A_1} \cup R_{A_4} \cup L$ and $S_3 := R_{A_3} \cup L'$, and if $\mathbb{W}_1 = \emptyset$, then we let $S_1 := R_{A_1} \cup R_{X_2} \cup R_{X_5}$, $S_2 := R_{A_2} \cup R_{A_4} \cup L$ and $S_3 := R_{A_3} \cup R_{A_5} \cup L'$. Then, as earlier by using Lemma 3.13:(iii), it is not hard to verify that S_1, S_2 and S_3 are the desired stable sets.

This completes the proof of Theorem 3.15. □

3.4.2 (P_5 , wheel)-free atoms that contain a C_5

Since each k -wheel, for $k \geq 6$ has a P_5 , by Theorem 3.15, we consider only (P_5 , wheel)-free atoms. Let G be a connected (P_5 , wheel)-free atom that contains a C_5 , say with vertex-set $\{v_1, v_2, v_3, v_4, v_5\}$

and the edge-set $\{v_1v_2, v_2v_3, v_3v_4, v_4v_5, v_5v_1\}$. Then we define the sets A , X , Y , Z and T as in Section 3.3 with $v_i \in A_i$, for each i , and we use the lemmas in Section 3.3. Let \mathcal{M} be the set of maximum cliques of G . Since G is 5-wheel-free, clearly $Z = \emptyset$. Thus, if $T \neq \emptyset$, then $G[T]$ is P_3 -free (by Lemma 3.10:(v)), and recall that by Lemma 3.10:(i) and Lemma 3.10:(iv), each vertex in $X \cup Y$ is either anticomplete to T or good with respect to T . Let L be the set that consists of one vertex from each T -clique; otherwise let $L := \emptyset$, and let L' be the set that consists of one vertex (which is not in L) from each non-trivial T -clique; otherwise let $L' := \emptyset$. Moreover, the graph G has some more structural properties, and are given in Lemmas 3.16 to 3.24 below.

Lemma 3.16 *The following hold, for each i :*

- (i) *Suppose that X_i and X_{i+1} are non-empty. If there is a vertex, say $p \in A_{i-2}$ such that $\{p\}$ is complete to $X_i \cup X_{i+1}$, then $X_i \cup X_{i+1}$ is a clique.*
- (ii) *Suppose K is an X_i -clique and K' is an X_{i+2} -clique. Then K is complete to K' or K is anticomplete to K' .*
- (iii) *Let K be an X_i -clique and let K' be an X_{i+2} -clique such that K is anticomplete to K' . Then either K is complete to A_{i+2} or K' is complete to A_i .*
- (iv) *If $X_{i+1} \neq \emptyset$, then X_i is anticomplete to X_{i+2} .*
- (v) *No vertex in T has neighbors in three consecutive X_i 's.*

Proof. (i): If X_i and X_{i+1} are cliques, then by Lemma 3.5:(v), the assertion holds. So, up to symmetry, suppose that there are non-adjacent vertices in X_i , say x and x' . Let $x'' \in X_{i+1}$. Then by Lemma 3.5:(v), $\{x''\}$ is complete to $\{x, x'\}$. Also, by our assumption, $\{p\}$ is complete to $\{x, x', x''\}$. Moreover, by Lemma 3.5:(i), x and x' have a common neighbor in A_{i+2} , say q . Now $\{x, q, x', x'', p\}$ induces a 4-wheel, a contradiction. So X_i is a clique, and by Lemma 3.5:(v), $X_i \cup X_{i+1}$ is a clique. This proves Lemma 3.16:(i). ■

(ii): It is enough to show that if a vertex in K has a neighbor in K' , then it is complete to K' . Suppose not. Then there are vertices, say $u \in K$ and $v, w \in K'$ such that $uv, vw \in E(G)$ and $uw \notin E(G)$. If v and w have a common neighbor in A_i , say p , then for any neighbor of u in A_{i+2} , say q , by Lemma 3.4:(ii), $\{p, u, q, w, v\}$ induces a 4-wheel, a contradiction. So we may assume that v and w do not share a common neighbor in A_i . So by the definition of X_{i+2} and Lemma 3.4:(v), both v and w are complete to A_{i-1} . Also there is a vertex, say $r \in A_i$ such that $rv \in E(G)$ and $rw \notin E(G)$. But then for any neighbor of u in A_{i+2} , say a , by Lemma 3.4:(ii), $\{u, r, v_{i-1}, w, a, v\}$ induces a 5-wheel, a contradiction. So Lemma 3.16:(ii) holds. ■

(iii): Suppose there are vertices, say $x \in K$, $a \in A_{i+2}$, $a' \in A_i$ and $x' \in K'$ such that $xa, x'a' \notin E(G)$. Let $a'' \in A_{i+2}$ be a neighbor of x . Then by Lemma 3.4:(iii), $aa'' \notin E(G)$. But then by Lemma 3.4:(ii), $\{a, x', a'', x, a'\}$ induces a P_5 , a contradiction. This proves Lemma 3.16:(iii). ■

(iv): Let $x \in X_i$ and $x' \in X_{i+2}$, and suppose x and x' are adjacent. Let $u \in X_{i+1}$. By Lemma 3.4:(v), we may assume that $\{u\}$ is complete to A_{i-2} . Now pick a neighbor of x in A_{i+2} , say p , and a

neighbor of x in A_{i-2} , say q . Then by Lemma 3.4:(ii) and Lemma 3.5:(v), $\{q, u, x', p, x\}$ induces a 4-wheel, a contradiction. So Lemma 3.16:(iv) holds. ■

(v): Suppose there is a vertex, say $t \in T$ which has neighbors, say $x_1 \in X_1$, $x_2 \in X_2$ and $x_3 \in X_3$. By Lemma 3.16:(iv), $x_1x_3 \notin E(G)$. Pick any $a \in A_4$ and $a' \in A_5$. Then by Lemma 3.5:(iii), $x_1a, x_2a', x_3a' \in E(G)$, and then $\{t, x_1, a, a', x_3, x_2\}$ induce a 5-wheel, a contradiction. So Lemma 3.16:(v) holds. □

Lemma 3.17 *For $i \in [5]$, let $j, k \in \{i+2, i-2\}$ and $j \neq k$, and let H be the subgraph induced by $X_i \cup A_{i+2} \cup A_{i-2}$. Then the following hold.*

- (i) *If M is a maximum clique in H such that $M \cap A_{i+2} \neq \emptyset$ and $M \cap A_{i-2} \neq \emptyset$, then $R_{A_{i+2}} \cup R_{A_{i-2}}$ meets M twice.*
- (ii) *Let $X^* \subseteq X_i$ be a non-empty clique. If every vertex in A_j has a non-neighbor in X^* , then A_k is a clique.*
- (iii) *If M is a maximum clique in H with $M \cap A_j = \emptyset$, then $M \cap X_i \neq \emptyset$, A_k is a clique, and $M \cap A_k = A_k$. Moreover, $R_{X_i} \cup R_{A_{i+2}} \cup R_{A_{i-2}}$ meets each maximum clique in H twice, and $R_{A_{i+2}} \cup R_{A_{i-2}}$ meets each maximal clique in H at least once.*
- (iv) *If $Y = \emptyset$ and if there is a maximum clique M in H with $|M| = \omega(G)$ and $M \cap A_{i-2} = \emptyset$ (or $M \cap A_{i+2} = \emptyset$), then G is a nice graph.*

Proof. (i): If $M \cap X_i = \emptyset$, then, by Lemma 3.4:(i), clearly the assertion holds; so assume that $M \cap X_i \neq \emptyset$. Let K be an A_{i+2} -clique such that $M \cap A_{i+2} \subseteq K$. We claim that $M \cap A_{i+2} = K$. Suppose not, and let $b \in K \setminus (M \cap A_{i+2})$. Since K is a clique, $\{b\}$ is complete to $M \cap A_{i+2}$. By Lemma 3.4:(iii), $M \cap X_i$ is complete to $\{b\}$. By the definition of A , $\{b\}$ is complete to $M \cap A_{i-2}$. So $\{b\}$ is complete to M , and hence $M \cup \{b\}$ is a larger clique in $G[X_i \cup A_{i+2} \cup A_{i-2}]$, a contradiction; so $M \cap A_{i+2}$ is an A_{i+2} -clique. By Lemma 3.4:(i), $R_{A_{i+2}}$ contains a vertex from each A_{i+2} clique, and $R_{A_{i-2}}$ contains a vertex from each A_{i-2} clique, we see that $R_{A_{i+2}} \cup R_{A_{i-2}}$ meets M twice. This proves Lemma 3.17:(i). ■

(ii): Suppose that $i = 1$, $j = 4$, and there are non-adjacent vertices in A_3 , say a, a' . Since $v_4 \in A_4$, v_4 has a non-neighbor in X^* , say x . Let p be a neighbor of x in A_4 , and let x' be a non-neighbor of p in X^* . Then, by Lemma 3.4:(v), $\{x, x'\}$ is complete to $\{a, a'\}$, and then $\{p, a, x', a', x\}$ induces a 4-wheel, a contradiction. So Lemma 3.17:(ii) holds. ■

(iii): To prove the first assertion, we let $j = i - 2$. Since A_{i-2} is complete to A_{i+2} , clearly $M \cap X_i \neq \emptyset$. Since $M \cap A_{i-2} = \emptyset$, every vertex in A_{i-2} has a non-neighbor in $M \cap X_i$, and hence, by Lemma 3.17:(ii), A_{i+2} is a clique. Then, by Lemma 3.4:(iii), $M \cap X_i$ is complete to A_{i+2} ; so $M \cap A_{i+2} = A_{i+2}$. To prove the second assertion, let M' be a maximum clique in H . By Lemma 3.17:(i), we may assume that one of $M' \cap A_{i+2} = \emptyset$, $M' \cap A_{i-2} = \emptyset$. If $M' \cap A_{i-2} = \emptyset$, then by the first assertion, since A_{i+2} is a clique, $M' = X^* \cup A_{i+2}$, where X^* is an X_i -clique. Thus $R_{X_i} \cup R_{A_{i+2}}$ meets M' twice, and $R_{A_{i+2}}$ meets M' at least once. Likewise, if $M' \cap A_{i+2} = \emptyset$, then $R_{X_i} \cup R_{A_{i-2}}$ meets M' twice, and $R_{A_{i-2}}$ meets M' at least once. This proves Lemma 3.17:(iii). ■

(iv): To prove the assertion, we let $i = 1$, and suppose that $M \cap A_4 = \emptyset$. As shown in the proof of second assertion of Lemma 3.17:(iii), $M = X^* \cup A_3$, where X^* is an X_1 -clique. Let $x \in X^*$, and let $a \in A_4$ be a neighbor of x . Then a has a non-neighbor in X^* , say x' . Then:

- (a) For any $p \in X_5$, by Lemma 3.4:(iii) and Lemma 3.5:(v), $M \cup \{p\}$ is a clique, a contradiction; so $X_5 = \emptyset$.
- (b) If there is a vertex, say $p \in X_3$, for any neighbor of p in A_5 , say q , since $\{p, q, a, x, x'\}$ does not induce a P_5 , p is adjacent to one of x, x' , then, by Lemma 3.16:(ii), $\{p\}$ is complete to X^* , and then, by Lemma 3.4:(ii), $M \cup \{p\}$ is a clique, a contradiction; so $X_3 = \emptyset$.
- (c) Suppose there is a vertex, say $p \in X_4$. Then for any neighbor of p in A_2 , say q , $\{q, p, a, x, x'\}$ does not induce a P_5 , p is adjacent to one of x, x' . Let K be the X_4 -clique containing p . Then, by Lemma 3.16:(ii), K is complete to X^* , and then, by Lemma 3.7, X^* is complete to exactly one A_4 -clique, say K' . Then since $M \cup K'$ is a clique, a contradiction. So $X_4 = \emptyset$.
- (d) If there are adjacent vertices, say $t \in T$ and $x_2 \in X_2$, and if K is the X_2 -clique containing x_2 , and Q is the A_4 -clique containing a , then by Lemma 3.5:(iii), $\{x\}$ is complete to A_4 , and then since $N(K) \cap Q \neq \emptyset$ and $N(X^*) \cap Q \neq \emptyset$, by Lemma 3.8, $ax' \in E(G)$, a contradiction; so X_2 is anticomplete to T .
- (e) If M' is a maximal clique in G such that $M' \cap T \neq \emptyset$, then since G is an atom, by (d), $M' \cap X_1 \neq \emptyset$, then, by Lemma 3.5:(iii), for any A_3 -clique D , and any A_4 -clique D' , $|(M' \cap X_1) \cup D \cup D'| \leq M$. Hence $|M' \cap T| \geq 2$.

Now by Lemma 3.4:(ii), Lemma 3.10:(i) and Lemma 3.17:(iii), the sets $S_1 := R_{A_2} \cup R_{A_5} \cup R_{X_1}$, $S_2 := R_{A_1} \cup R_{A_3} \cup R_{X_2} \cup L$ and $S_3 := R_{A_4} \cup L'$ are the required stable sets. So G is nice. This proves Lemma 3.17:(iv). \square

Lemma 3.18 *If Y is empty, and if there is an $i \in [5]$ such that X_i is not anticomplete to X_{i+2} , then G is nice.*

Proof. We may assume that $i = 1$. Then there are vertices, say $x_1 \in X_1$ and $x_3 \in X_3$ such that $x_1x_3 \in E(G)$. Then by Lemma 3.16:(iv), $X_2 = \emptyset$; so $X = X_1 \cup X_3 \cup X_4 \cup X_5$. Let Q_1 be the X_1 -clique containing x_1 , and let Q_3 be the X_3 -clique containing x_3 . Then by Lemma 3.7 and Lemma 3.16:(ii), Q_1 is complete to Q_3 , and anticomplete to $(X_3 \setminus Q_3) \cup X_4$, Q_3 is anticomplete to $(X_1 \setminus Q_1) \cup X_5$, and $X_1 \setminus Q_1$ is anticomplete to $X_3 \setminus Q_3$. By Lemma 3.7, let A_1^* be the A_1 -clique such that Q_3 is complete to A_1^* , and anticomplete to $A_1 \setminus A_1^*$, and let A_3^* be the A_3 -clique such that Q_1 is complete to A_3^* , and anticomplete to $A_3 \setminus A_3^*$. By Lemma 3.4:(iv) and Lemma 3.5:(i), X_1 is complete to A_3^* , and X_3 is complete to A_1^* .

Note that any maximal clique containing at least one vertex from each X_1 and X_3 is either $A_1^* \cup Q_1 \cup Q_3$ or $A_3^* \cup Q_1 \cup Q_3$. By Lemma 3.7, any maximal clique containing at least one vertex from each X_1 and X_4 is of the form $D_1 \cup X_1^* \cup X_4^*$ or $D_4 \cup X_1^* \cup X_4^*$, where D_1, D_4, X_1^* and X_4^* are A_1, A_4, X_1 and X_4 -cliques respectively, and $X_1^* \neq Q_1$. Also, any maximal clique containing at

least one vertex from each X_3 and X_5 is of the form $D_3 \cup X_3^* \cup X_5^*$ or $D_5 \cup X_3^* \cup X_5^*$, where D_3 , D_5 , X_3^* , X_5^* are A_3 , A_5 , X_3 and X_5 -cliques respectively, and $X_3^* \neq Q_3$.

By Lemma 3.17:(iv), we may assume that each maximal clique of G in $G[X_i \cup A_{i+2} \cup A_{i+2}]$ has non-empty intersection with both A_{i+2} and A_{i-2} ; and by Lemma 3.17:(iii), $R_{A_{i+2}} \cup R_{A_{i-2}}$ meet rest of the maximal cliques in $G[X_i \cup A_{i+2} \cup A_{i+2}]$ at least once.

First suppose that $T = \emptyset$. Also assume that Q_1 is either complete or anticomplete to every A_4 -clique, and Q_3 is either complete or anticomplete to every A_5 -clique. Now suppose there is an A_2 -clique, say D_2 , such that either $A_1^* \cup D_2 \in \mathcal{M}$ or $A_3^* \cup D_2 \in \mathcal{M}$. Up to relabeling, we may assume that $A_1^* \cup D_2 \in \mathcal{M}$. Then since $|A_1^* \cup D_2| \geq |A_1^* \cup Q_1 \cup Q_3|$, we have $|D_2| > |Q_1|$. Further, we have the following:

- (a) Any maximal clique that contain at least one vertex from each A_4 and Q_1 is of the form $A_3^* \cup Q_1 \cup D_4$, where D_4 is an A_4 -clique.
- (b) For any A_1 -clique D_1 , since $|D_2| > |Q_1|$, we have $D_1 \cup Q_1 \notin \mathcal{M}$.
- (c) If $X_5 \neq \emptyset$, since X_5 is anticomplete to Q_3 , by Lemma 3.6, each X_5 -clique is either complete or anticomplete to an A_3 -clique. So for any X_5 -clique X_5^* which is anticomplete to A_3^* , by Lemma 3.4:(v), X_5^* is complete to D_2 , and $|Q_1 \cup X_5^*| < |D_2 \cup X_5^*|$ which implies that $Q_1 \cup X_5^* \notin \mathcal{M}$. Moreover, for any X_5 -clique X_5^{**} which is complete to A_3^* , any maximal clique that contain at least one vertex from each X_5^{**} and Q_1 is of the form $A_3^* \cup Q_1 \cup X_5^{**}$.

By (a), (b) and (c), it is not hard to verify that $S_1 := R_{A_2} \cup R_{X_1 \setminus Q_1} \cup R_{X_3}$, $S_2 := R_{A_3} \cup R_{A_5} \cup R_{X_4}$ and $S_3 := R_{A_1} \cup R_{A_4} \cup R_{X_5}$ are the required stable sets. So we assume that for any A_2 -clique D_2 , $A_1^* \cup D_2, A_3^* \cup D_2 \notin \mathcal{M}$. Next we claim the following:

3.18.1 *Either for each $W \in \mathbb{W}_1$, $W \cap A_1^* = \emptyset$ or for each $W' \in \mathbb{W}_3$, $W' \cap A_3^* = \emptyset$.*

Proof of 3.18.1. Suppose there is an X_1 -clique K such that $K \cup A_1^* \in \mathbb{W}_1$, and there is an X_3 -clique K' such that $K' \cup A_3^* \in \mathbb{W}_3$. Note that $K \neq Q_1$ and $K' \neq Q_3$. Then K is anticomplete to K' . Let D_5 be an A_5 -clique such that $N(K') \cap D_5 \neq \emptyset$. Then, by Lemma 3.6, K' is complete to D_5 . Now $|A_1^* \cup K| \geq |A_1^* \cup D_5 \cup K'|$, and so $|K| > |K'|$. Then $A_3^* \cup K$ is a clique, and $|A_3^* \cup K| > |A_3^* \cup K'|$ which is a contradiction. So 3.18.1 holds. ■

By 3.18.1, we may assume, up to symmetry, that for each $W \in \mathbb{W}_1$, we have $W \cap A_1^* = \emptyset$. Now if for each A_5 -clique D_5 , $D_5 \cup A_1^* \notin \mathcal{M}$, then clearly $S_1 := R_{A_1 \setminus A_1^*} \cup R_{A_4} \cup R_{Q_3} \cup R_{X_5}$, $S_2 := R_{A_2} \cup R_{X_1} \cup R_{X_3 \setminus Q_3}$ and $S_3 := R_{A_3} \cup R_{A_5} \cup R_{X_4}$ are the required stable sets. So suppose that there is an A_5 -clique, say D_5 , such that $D_5 \cup A_1^* \in \mathcal{M}$. Then since $Q_3 \cup D_5 \cup A_1^*$ is not a clique, Q_3 is anticomplete to D_5 . Then, by Lemma 3.4:(v), Q_3 is complete to A_1 ; so $A_1 = A_1^*$, and hence $\mathbb{W}_1 = \emptyset$. Also, if $X_5 \neq \emptyset$, then since Q_3 is anticomplete to X_5 , by Lemma 3.16:(iii), X_5 is complete to A_3 . Thus, by Lemma 3.8, any maximum clique containing at least one vertex from each X_1 and X_5 is of the form $D_3 \cup X_1^* \cup X_5^*$, where X_1^* , X_5^* and D_3 are X_1 -clique, X_5 -clique and A_3 -clique respectively. Now we let $S_1 := R_{A_2} \cup R_{A_4} \cup R_{X_3}$, $S_2 := R_{A_3} \cup R_{A_5} \cup R_{X_4}$ and $S_3 := R_{A_1} \cup R_{X_5}$, and we conclude that S_1 , S_2 and S_3 are the required stable sets. So suppose that, up to relabeling,

there is an A_5 -clique, say D_5 , such that Q_3 is neither complete nor anticomplete to D_5 . Then since $(X_1 \setminus Q_1) \cup X_5$ is anticomplete to Q_3 , by Lemma 3.6, $(X_1 \setminus Q_1) \cup X_5 = \emptyset$. So $X_1 = Q_1$ and X_1 is anticomplete to X_4 (by Lemma 3.7). Now we let $S_1 := R_{A_5} \cup R_{X_1} \cup R_{X_4}$, $S_2 := R_{A_2} \cup R_{A_4} \cup R_{X_3}$ and $S_3 := R_{A_1} \cup R_{A_3}$. Then clearly S_1, S_2 and S_3 are the required stable sets.

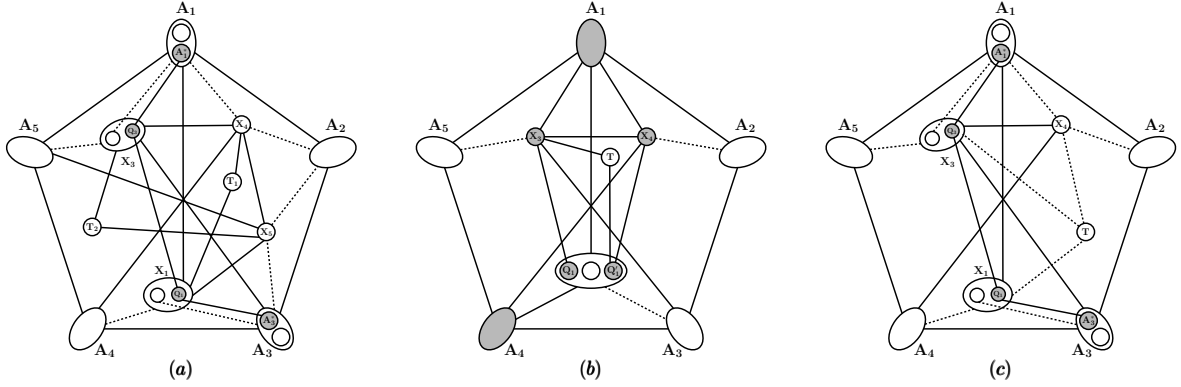

Figure 12: Sketch of the graph G in Lemma 3.18 when $T \neq \emptyset$, and: (a) $X_4, X_5 \neq \emptyset$. (b) X_1 is not anticomplete to X_4 . (c) X_1 is anticomplete to X_4 .

So we may assume that $T \neq \emptyset$. (We refer to Figure 12 for a sketch of the graph G .) Recall that each vertex in X is either anticomplete to T or good with respect to T . First suppose $X_4, X_5 \neq \emptyset$. So, by Lemma 3.16:(iv), X_1 is anticomplete to X_4 , and X_3 is anticomplete to X_5 . Let T_1 denote the union of T -cliques which are complete to $X_1 \cup X_4$, and anticomplete to $X_3 \cup X_5$, and let T_2 denote the union of T -cliques which are complete to $X_3 \cup X_5$, and anticomplete to $X_1 \cup X_4$. Clearly $T_1 \cap T_2 = \emptyset$. Moreover:

3.18.2 $T = T_1 \cup T_2$.

Proof of 3.18.2. Let $t \in T$, and let T' be the T -clique containing t . Since every vertex in T has a neighbor in X , first assume that t has a neighbor in $X_1 \cup X_4$. Since X_1 is anticomplete to X_4 , by Lemma 3.11, $\{t\}$ is complete to $X_1 \cup X_4$. So by Lemma 3.16:(v), $\{t\}$ is anticomplete to X_5 , and since X_3 is anticomplete to X_5 , by Lemma 3.11, $\{t\}$ is anticomplete to X_3 . Thus, by Lemma 3.10:(i), T' is complete to $X_1 \cup X_4$, and anticomplete to $X_3 \cup X_5$, and so $T' \in T_1$. Similarly, if t has a neighbor in $X_3 \cup X_5$, then T' is complete to $X_3 \cup X_5$, and anticomplete to $X_1 \cup X_4$, and so $T' \in T_2$. This proves 3.18.2. ■

Since $T \neq \emptyset$, by Lemma 3.5:(iii), for $j \in \{3, 4, 5\}$, either X_j is complete to A_{j-2} or X_{j+1} is complete to A_{j-2} ; so any maximal clique containing at least one vertex from each X_j and X_{j+1} must be complete to A_{j-2} (by Lemma 3.8). Since at least one of X_4 and X_5 is complete to A_2 , by Lemma 3.8 and Lemma 3.9, one of \mathbb{W}_4 and \mathbb{W}_5 is empty. Moreover, if $T^* \cup X^* \in \mathcal{M}$ for a T -clique T^* , and an X_i -clique X^* , where $i \in \{1, 3, 4, 5\}$, then by Lemma 3.5:(iii), for any $p \in A_{i+2}$ and $q \in A_{i-2}$, $|T^* \cup X^*| \geq |X^* \cup \{p, q\}|$, and thus $|T^*| \geq 2$. Now, if $\mathbb{W}_5 = \emptyset$, then we let $S_1 := R_{A_5} \cup R_{X_1} \cup R_{X_4} \cup (L \cap T_2)$, $S_2 := R_{A_2} \cup R_{A_4} \cup R_{X_3} \cap (L \cap T_1)$ and $S_3 := R_{A_1} \cup R_{A_3} \cup (L' \cap T_2)$,

and if $\mathbb{W}_4 = \emptyset$, then we let $S_1 := R_{A_4} \cup R_{X_3} \cup R_{X_5} \cup (L \cap T_1)$, $S_2 := R_{A_2} \cup R_{A_5} \cup R_{X_1} \cup (L \cap T_2)$ and $S_3 := R_{A_1} \cup R_{A_3} \cup (L' \cap T_1)$. Then we observe that S_1, S_2 , and S_3 are the required stable sets.

Next we assume that one of X_4 and X_5 is empty, say $X_5 = \emptyset$. First suppose that X_1 is not anticomplete to X_4 . So there are vertices, say $x'_1 \in X_1$, $x_4 \in X_4$ such that $x'_1 x_4 \in E(G)$. So $X = X_1 \cup X_3 \cup X_4$. Let Q'_1 be the X_1 -clique containing x'_1 , and let Q_4 be the X_4 -clique containing x_4 . Then by Lemma 3.7 and Lemma 3.16:(ii), $Q_1 \neq Q'_1$, Q'_1 is complete to Q_4 , Q'_1 is anticomplete to $X_4 \setminus Q_4$, Q_4 is anticomplete to $X_1 \setminus Q'_1$, $X_1 \setminus Q'_1$ is anticomplete to $X_4 \setminus Q_4$. By Lemma 3.7, let A_1^{**} be the A_1 -clique such that Q_4 is complete to A_1^{**} and anticomplete to $A_1 \setminus A_1^{**}$, and let A_4^* be the A_4 -clique such that Q'_1 is complete to A_4^* , and anticomplete to $A_4 \setminus A_4^*$. By Lemma 3.4:(iv) and Lemma 3.5:(i), X_4 is complete to A_1^{**} . By Lemma 3.11, each vertex in T has a neighbor in X_1 . Further we claim the following:

3.18.3 A_1, X_3 and X_4 are cliques. Moreover, T is complete to exactly one of X_3 and X_4 .

Proof of 3.18.3. We first show that, if $\{x_3\}$ is not anticomplete to T , then $\{x_4\}$ is anticomplete to T , and vice versa. Suppose not, and let $t, t' \in T$ be such that $x_3 t, x_4 t' \in E(G)$. If $x_4 t \in E(G)$, then, by Lemma 3.11, $x_1 t \in E(G)$, and then by Lemma 3.5:(iii), for any $a \in A_1$, $\{a, x_1, t, x_4, x_3\}$ induces a 4-wheel, a contradiction; so $x_4 t \notin E(G)$. Likewise, $x_3 t' \notin E(G)$. Also, by Lemma 3.10:(i), $tt' \notin E(G)$, and by Lemma 3.11, $x_1 t', x'_1 t \in E(G)$ and $x_1 t, x'_1 t' \notin E(G)$. But then $\{t, x'_1, x_4, t', x_1\}$ induces a P_5 , a contradiction. By symmetry, we may assume that $\{x_3\}$ is not anticomplete to T . Then $\{x_4\}$ is anticomplete to T . Then, by Lemma 3.11, T is anticomplete to $X_1 \setminus Q'_1$. Since each vertex in T has a neighbor in X_1 , each vertex in T has a neighbor in Q'_1 . So by Lemma 3.10:(i) and Lemma 3.11, T is complete to $Q'_1 \cup Q_3$. By Lemma 3.5:(iii), $A_1 = A_1^* = A_1^{**}$ is a clique. So by Lemma 3.16:(i), $X_3 \cup X_4$ is a clique, and hence $X_3 = Q_3$ and $X_4 = Q_4$ are cliques. Since T is anticomplete to $X_1 \setminus Q'_1$, by Lemma 3.11, T is anticomplete to $Q_4 = X_4$. This proves 3.18.3. ■

By 3.18.3, we may assume that T is complete to $X_3 (= Q_3)$, and anticomplete to $X_4 (= Q_4)$. Then by Lemma 3.11, it follows that, T is complete to Q'_1 (and anticomplete to $X_1 \setminus Q'_1$). Then by Lemma 3.5:(iii), Q'_1 is complete to A_4 , and hence $A_4 = A_4^*$ is a clique. Since $Q'_1 \cup Q_4 \cup A_4$ is a larger clique than $Q_4 \cup A_4$, we conclude that $\mathbb{W}_4 = \emptyset$, and $R_T \cup R_{X_3} \cup R_{Q'_1}$ meets each maximal clique of G in $G[X \cup T]$ twice. Now we see that $S_1 := R_{A_2} \cup R_{A_5} \cup R_{X_1}$, $S_2 := R_{A_4} \cup R_{X_3}$ and $S_3 := R_{A_1} \cup R_{A_3} \cup R_T$ are the required stable sets.

Finally we assume that either X_1 is anticomplete to X_4 or $X_4 = \emptyset$. We claim the following:

3.18.4 Each T -clique is complete to either Q_1 or Q_3 .

Proof of 3.18.4. Suppose not. Then there is a T -clique, say T^* , and vertices $x \in Q_1$, $x' \in Q_3$, and $t, t' \in T^*$ such that $xt, xt' \notin E(G)$. Then by Lemma 3.10:(i), T^* is anticomplete to $\{x, x'\}$. So by Lemma 3.7 and Lemma 3.11, T^* is anticomplete to $(X_1 \setminus Q_1) \cup (X_3 \setminus Q_3) \cup X_4$. Since each vertex of T has a neighbor in X , $N(T^*) \cap X \subseteq Q_1 \cup Q_3$ which is a clique cut-set of G , a contradiction. So 3.18.4 holds. ■

Moreover, if there is a T -clique T^* such that $N(T^*) \cap (X_4 \cup (X_3 \setminus Q_3)) \neq \emptyset$, then by Lemma 3.11, T^* is complete to Q_1 , and hence T^* is complete to $X_4 \cup (X_3 \setminus Q_3)$. Now we let $S_1 := R_{A_5} \cup R_{X_1} \cup R_{X_4}$, $S_2 := R_{A_2} \cup R_{A_4} \cup R_{X_3}$ and $S_3 := R_{A_1} \cup R_{A_3} \cup R_T$. Then by 3.18.4, we conclude that S_1, S_2 and S_3 are the desired stable sets. This completes the proof of Lemma 3.18. \square

Lemma 3.19 *If X is non-empty and Y is empty, then G is a nice graph.*

Proof. By Lemma 3.17:(iv), we may assume that each maximal clique of G in $G[X_i \cup A_{i+2} \cup A_{i+2}]$ has non-empty intersection with both A_{i+2} and A_{i-2} ; and by Lemma 3.17:(iii), $R_{A_{i+2}} \cup R_{A_{i-2}}$ meets rest of the maximal cliques in $G[X_i \cup A_{i+2} \cup A_{i+2}]$ at least once. Recall that each vertex in X is either anticomplete to T or good with respect to T . First suppose that $X \setminus X_1 = \emptyset$. If T^* is a T -clique such that $T^* \subset M \in \mathcal{M}$, then since each vertex in X_1 is either anticomplete to T or good with respect to T , $M = T^* \cup X_1^*$ where X_1^* is a subset of some X_1 -clique. Since $N(T^*) \cap X_1$ is not a clique cut-set of G , there are non-adjacent vertices in $N(T^*) \cap X_1$. Then by Lemma 3.5:(ii) and Lemma 3.5:(iii), $A_3 \cup A_4$ is clique, and so $A_3 \cup A_4 \cup X_1^*$ is a clique. Hence $|T^* \cup X_1^*| \geq |A_3 \cup A_4 \cup X_1^*|$, and thus $|T^*| \geq 2$. Then clearly $S_1 := R_{X_1} \cup R_{A_2} \cup R_{A_5}$, $S_2 := R_{A_1} \cup R_{A_3} \cup L$ and $S_3 := R_{A_4} \cup L'$ are the desired stable sets. Let J denote the set $\{i \in [5] \mid X_i \neq \emptyset\}$, and we may assume that $|J| \geq 2$. By Lemma 3.18, we may assume that for each $i \in [5]$, X_i is anticomplete to X_{i+2} . See Figure 13:(a) and Figure 13:(b). First we claim the following.

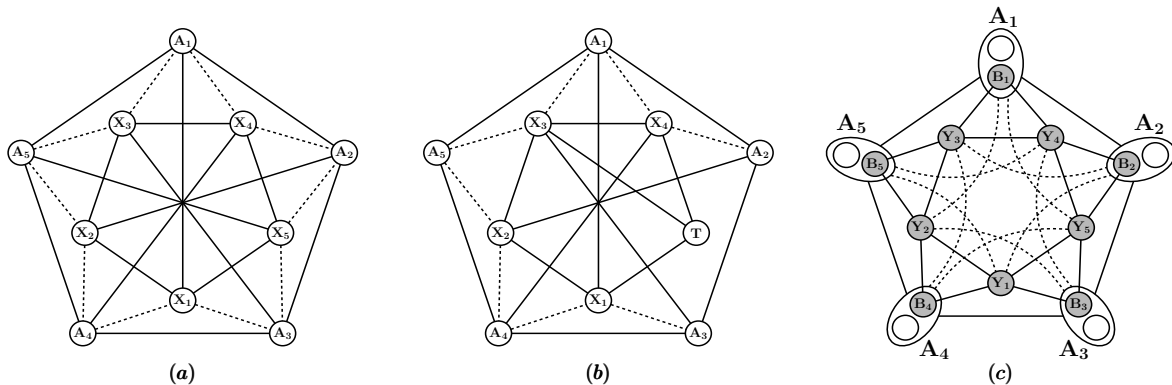

Figure 13: Sketch of the graph G in: (a) Lemma 3.19 when $T = \emptyset$. (b) Lemma 3.19 when $T \neq \emptyset$ and $\ell = 5$. (c) Lemma 3.24 when Y_i is anticomplete to $Y_{i+2} \cup Y_{i-2}$, for each $i \in [5]$.

3.19.1 *There is an index $\ell \in [5]$ such that $\mathbb{W}_\ell = \emptyset$, and for $p \in \{\ell+1, \ell-1\}$, $R_{X_p} \cup R_{A_1} \cup \dots \cup R_{A_5}$ meets each maximum clique of G in $G[A \cup X_\ell \cup X_p]$ at least twice.*

Proof of 3.19.1. If there is an index $i \in [5]$ such that $X_i = \emptyset$, we choose $\ell = i$, and by Lemma 3.17:(i), we are done; so for each $i \in [5]$, $X_i \neq \emptyset$. First suppose there is an index $i \in [5]$, X_i and X_{i+1} is not complete to A_{i-2} , say $i = 1$. Then by Lemma 3.16:(iii), X_4 is complete to $A_1 \cup A_2$, and, up to relabeling, X_3 is complete to A_5 . Since X_4 is complete to A_1 , by Lemma 3.9, one of \mathbb{W}_3 and \mathbb{W}_4 is empty. Now if $\mathbb{W}_3 = \emptyset$, then we choose $\ell = 3$, otherwise we choose $\ell = 4$. Note that, by Lemma 3.8, for $k \in \{2, 3, 4\}$, any maximal clique containing at least one vertex from each X_k and

X_{k+1} must contain a vertex from $R_{A_{k-2}}$. Thus, by Lemma 3.17:(i), we conclude the proof. So we may assume that for each $i \in [5]$, one of X_i or X_{i+1} is complete to A_{i-2} . Then by Lemma 3.8 and Lemma 3.9, there is an index $k \in [5]$ such that $\mathbb{W}_k = \emptyset$. Since by Lemma 3.8, for $i \in [5]$, any maximal clique containing at least one vertex from each X_i and X_{i+1} must contain a vertex from $R_{A_{i-2}}$, by Lemma 3.17:(i), we conclude that $\ell = k$ is our desired index. This proves 3.19.1. ■

3.19.2 *If $T \neq \emptyset$, then there is an index $j \in [5]$ such that $X_{j-1} = \emptyset$ (so $\mathbb{W}_{j-1} = \emptyset$), and each T -clique is complete to $X_j \cup X_{j+2} \cup X_{j-2}$, and anticomplete to X_{j+1} .*

Proof of 3.19.2. Let $t \in T$. Let T^* be the T -clique containing t . By Lemma 3.20:(vi), there is an $i \in [5]$ such that $N(T^*) \cap X_i \neq \emptyset$. Suppose $N(T^*) \cap X_{i+1} \neq \emptyset$. Then by Lemma 3.10:(i), Lemma 3.11 and Lemma 3.16:(v), we may assume that X_{i+2} and X_{i-1} are empty. If $X_{i-2} = \emptyset$, then by Lemma 3.5:(iii) and Lemma 3.16:(i), $X_i \cup X_{i+1}$ is a clique, and so $N(T^*) \cap (X_i \cup X_{i+1})$ is a clique cut-set, a contradiction; so $X_{i-2} \neq \emptyset$. Then by Lemma 3.11, T^* is complete to $X_i \cup X_{i+1} \cup X_{i-2}$. So we take $j = i - 2$ and we are done. Thus, by Lemma 3.10:(i), we may assume that $N(T^*) \cap (X_{i-1} \cup X_{i+1}) = \emptyset$. We claim that $X_{i-2} \cup X_{i+2} \neq \emptyset$. Suppose not. Since $|J| \geq 2$, we may assume that $X_{i+1} \neq \emptyset$. Then since $N(T^*) \cap X_i$ is not a clique cut-set of G , there are non-adjacent vertices, say $u, v \in X_i$ such that $u, v \in N(T^*)$. Then by Lemma 3.5:(ii) and Lemma 3.5:(iii), A_{i-2} is a clique, and so $X_i \cup X_{i+1}$ is complete to A_{i-2} (by Lemma 3.4:(iii)). But then, by Lemma 3.16:(i), X_i is a clique, a contradiction. Thus $X_{i-2} \cup X_{i+2} \neq \emptyset$. Then by Lemma 3.11, T^* is complete to $X_i \cup X_{i+2} \cup X_{i-2}$. Also, by Lemma 3.16:(v), T^* is anticomplete to X_{i+1} . So we take $j = i$. This proves 3.19.2. ■

By 3.19.1, let $\ell \in [5]$ be the index such that $\mathbb{W}_\ell = \emptyset$, and for $p \in \{\ell+1, \ell-1\}$, $R_{X_p} \cup R_{A_1} \cup \dots \cup R_{A_5}$ meets each maximum clique of G in $G[A \cup X_\ell \cup X_p]$ at least twice. If $T \neq \emptyset$, then we choose $\ell = j - 1$ (by 3.19.2). Now we let $S_1 := R_{X_{\ell-1}} \cup R_{A_\ell} \cup R_{X_{\ell+1}}$, $S_2 := R_{A_{\ell+1}} \cup R_{X_{\ell+2}} \cup R_{A_{\ell-2}} \cup R_T$ and $S_3 := R_{A_{\ell+2}} \cup R_{X_{\ell-2}} \cup R_{A_{\ell-1}}$. Clearly S_1, S_2 and S_3 are stable sets. By 3.19.2, $R_{X_{j-2}} \cup R_{X_j} \cup R_{X_{j+1}} \cup R_{X_{j+2}} \cup R_T$ meets each maximum clique of G in $G[X \cup T]$ at least twice. Also, using Lemma 3.8 and Lemma 3.17:(i), we see that $(\bigcup_{k=1}^5 R_{A_k}) \cup R_{X_{\ell-2}} \cup R_{X_{\ell-1}} \cup R_{X_{\ell+1}} \cup R_{X_{\ell+2}}$ meets each maximum clique of G in $G[A \cup (X \setminus X_\ell)]$ twice. So, by 3.19.1, we conclude that $S_1 \cup S_2 \cup S_3$ meets each maximum clique of G at least twice, and meets other maximal cliques of G at least once. So G is nice. This completes the proof of Lemma 3.19. □

Lemma 3.20 *The following hold, for each i :*

- (i) *If K is an A_{i+2} -clique (or an A_{i-2} -clique), then any vertex in Y_i which has a neighbor in K is complete to K .*
- (ii) *For $j \in \{i-2, i+2\}$, each vertex in Y_i is complete to exactly one A_j -clique.*
- (iii) *If a vertex in Y_i is not complete to A_{i-1} (or A_{i+1}), then it is complete to $A_{i+2} \cup A_{i-2}$, and so $A_{i+2} \cup A_{i-2}$ is a clique.*
- (iv) *Y_i is a clique.*
- (v) *Y_i is complete to $Y_{i+1} \cup Y_{i-1}$.*

(vi) Every vertex in T has a neighbor in X .

Proof. (i): By symmetry, it is enough to prove the assertion for A_{i+2} . If there is a vertex in Y_i , say y such that $\{y\}$ is not complete to K , then by assumption, there are vertices, say a, b in K such that $ab, ay \in E(G)$ and $by \notin E(G)$. But then for any neighbor of y in A_{i-1} , say c , $\{b, a, y, c, v_i\}$ induces a P_5 , a contradiction. So Lemma 3.20:(i) holds. ■

(ii): We may assume, up to symmetry, that $j = i + 2$. Let $y \in Y_i$. By Lemma 3.20:(i), it is enough to show that y has a neighbor in exactly one A_{i+2} -clique. Suppose not. Then there are non-adjacent vertices, say a and b in A_{i+2} such that y is adjacent to both a and b . Then pick a neighbor of y in each A_{i-2} and A_{i+1} , say p and q respectively; but then $\{p, a, q, b, y\}$ induces a 4-wheel which is a contradiction. So Lemma 3.20:(ii) holds. ■

(iii): Let $y \in Y_i$. We may assume, up to symmetry, that $\{y\}$ is not complete to A_{i-1} , and let p be a non-neighbor of y in A_{i-1} . So by Lemma 3.10:(ii), A_{i-1} is a clique. Suppose to the contrary that y has a non-neighbor in $A_{i-2} \cup A_{i+2}$, say q . If $q \in A_{i-2}$, then for any neighbor of y in A_{i+1} , say r , we see that $\{q, p, v_i, r, y\}$ induces a P_5 , a contradiction; so $q \in A_{i+2}$. Pick a neighbor of y in each A_{i-1} and A_{i+1} , say a and b respectively. Since A_{i-1} is a clique, $pa \in E(G)$. Now we see that $\{p, a, y, b, q\}$ induces a P_5 , a contradiction. So the first assertion of Lemma 3.20:(iii) holds, and the second assertion follows from Lemma 3.20:(ii). ■

(iv): Let $y, y' \in Y_i$, and suppose y and y' are non-adjacent. By Lemma 3.10:(iii), we may assume that $\{y\}$ is complete to A_{i-1} . Then by the definition of Y_i , clearly y and y' have a common neighbor in A_{i-1} , say p . So by the definition of Y_i and by Observation 1, y and y' have a common neighbor in A_{i+2} , say q . By the same argument, if y and y' have a common neighbor in A_{i+1} , then they have a common neighbor in A_{i-2} . If y and y' do not share a common neighbor in A_{i+1} , then by Lemma 3.20:(iii), A_{i-2} is a clique, and so by Lemma 3.20:(i), y and y' have a common neighbor in A_{i-2} . In either case, y and y' have a common neighbor in A_{i-2} , say r . Then $\{p, y, q, y', r\}$ induces a 4-wheel, a contradiction. So Lemma 3.20:(iv) holds. ■

(v): Let $y \in Y_i$ and $y' \in Y_{i+1}$, and suppose y and y' are non-adjacent. Let p be a neighbor of y in A_{i-2} . If $py' \notin E(G)$, then for any neighbor of y' in A_i , say a , and for any neighbor of y in A_{i+1} , say b , $\{p, y, b, a, y'\}$ induces a P_5 , a contradiction; so we may assume that $py' \in E(G)$. Also it follows from the definition of Y_{i+1} , and by Lemma 3.10:(ii) and Lemma 3.20:(i), that y and y' have a common neighbor in A_{i-1} , say q , and by the same argument, y and y' have a common neighbor in A_{i+2} , say r . But then $\{y', q, y, r, p\}$ induces a 4-wheel, a contradiction. So Y_i is complete to Y_{i+1} . Likewise, Y_i is complete to Y_{i-1} . So Lemma 3.20:(v) holds. ■

(vi): Suppose there is a vertex, say $t \in T$ which has no neighbor in X . Let Q be the vertex-set of the component of $G[T]$ containing t . Then by Lemma 3.10:(i), Q is anticomplete to X . Then since G is connected, $N(Q) \cap Y \neq \emptyset$. Since $N(Q) \cap Y$ is not a clique cut-set between A and Q , there are non-adjacent vertices, say $y, y' \in N(Q) \cap Y$. Then by Lemma 3.20:(iv) and Lemma 3.20:(v), we

may assume that $y \in Y_2$ and $y' \in Y_5$. Now pick a neighbor of y in A_5 , say a , and a neighbor of y' in A_2 , say a' . But then $\{a, y, t, y', a'\}$ induces a P_5 , a contradiction. So Lemma 3.20:(vi) holds. \square

Lemma 3.21 *For each $i \in [5]$, $Y_i \cup Y_{i+1}$ is complete to exactly one A_{i-2} -clique.*

Proof. First we show that for each i , Y_i is complete to exactly one A_{i-2} -clique. Suppose not. Then by Lemma 3.20:(i), Lemma 3.20:(ii) and Lemma 3.20:(iv), there are adjacent vertices, say y and y' in Y_i , and non-adjacent vertices, say a and b in A_{i-2} such that $ya, y'b \in E(G)$ and $yb, y'a \notin E(G)$. Then by Lemma 3.20:(iii), $\{y, y'\}$ is complete to A_{i+1} and A_{i-1} . Now if y and y' have a common neighbor in A_{i+2} , say p , then $\{p, y, v_{i-1}, b, y'\}$ induces a 4-wheel, a contradiction; so we may assume that there is a vertex, say $q \in A_{i+2}$ such that $yq \in E(G)$ and $y'q \notin E(G)$. But then $\{v_{i+1}, q, a, v_{i-1}, y', y\}$ induces a 5-wheel, a contradiction. So for each i , Y_i is complete to exactly one A_{i-2} -clique.

Now suppose that the lemma is not true. Then by our preceding argument, there are A_{i-2} -cliques, say B and D , such that $B \cap D = \emptyset$, Y_i is complete to B , and anticomplete to $A_{i-2} \setminus B$, and Y_{i+1} is complete to D , and anticomplete to $A_{i-2} \setminus D$. Then clearly A_{i-2} is not a clique, and so by Lemma 3.20:(iii), Y_i is complete to A_{i-1} , and Y_{i+1} is complete to A_{i+2} . Now pick a vertex $y \in Y_i$, and a neighbor of y in A_{i+2} , say a . Also, pick a vertex $y' \in Y_{i+1}$, and neighbor of y' in A_{i-1} , say a' . But now for any $b \in B$, by Lemma 3.20:(v), $\{y', a, b, a', y\}$ induces a 4-wheel, a contradiction. So Lemma 3.21 holds. \square

If $Y \neq \emptyset$, by Lemma 3.21, for $i \in [5]$, let B_{i-2} be the A_{i-2} -clique such that $Y_i \cup Y_{i+1}$ is complete to B_{i-2} , and anticomplete to $A_{i-2} \setminus B_{i-2}$, and let B_{i+2} be the A_{i+2} -clique such that $Y_i \cup Y_{i-1}$ is complete to B_{i+2} , and anticomplete to $A_{i+2} \setminus B_{i+2}$.

Lemma 3.22 *The following hold, for each i :*

- (i) *For $j \in \{i-1, i+1\}$, each A_j -clique has a vertex which is complete to Y_i .*
- (ii) *Y_{i+1} is anticomplete to $X_i \cup X_{i+2}$.*
- (iii) *At least one of $X_i, Y_{i+2} \cup Y_{i-2}$ is empty.*
- (iv) *Each $y \in Y_{i+1}$ and $x \in X_i$ have a common neighbor in each A_i, A_{i+2} and A_{i-2} , and each $y \in Y_{i+1}$ and $x \in X_{i+2}$ have a common neighbor in each A_i, A_{i+2} and A_{i-1} .*
- (v) *If $X_i \neq \emptyset$, then $Y_{i+1} \cup Y_{i-1}$ is complete to A_i .*
- (vi) *If $X \neq \emptyset$, then Y_i is anticomplete to $Y_{i+2} \cup Y_{i-2}$.*
- (vii) *If $X \neq \emptyset$, then no vertex in T has neighbors in both Y_{i-1} and Y_{i+1} .*

Proof. (i): We prove the statement for $j = i+1$. If A_{i+1} is not a clique, then by Lemma 3.10:(ii), Y_i is complete to A_{i+1} , and Lemma 3.22:(i) holds; so assume that A_{i+1} is a clique. Now if $G[Y_i \cup A_{i+1}]$ contains a C_4 , say with vertex-set $\{p, q, r, s\}$, then for any $a \in B_{i+2}$, $\{p, q, r, s, a\}$ induces a 4-wheel, a contradiction; so $G[Y_i \cup A_{i+1}]$ is C_4 -free. Since Y_i is a clique (by Lemma 3.20:(iv)) and since each vertex in Y_i has a neighbor in A_{i+1} (which is a clique), by Lemma 3.2, A_{i+1} has a vertex which is complete to Y_i . This proves Lemma 3.22:(i). \blacksquare

(ii): Suppose, up to symmetry, there are adjacent vertices, say $y \in Y_{i+1}$ and $x \in X_i$. Pick a neighbor of y in each A_{i-1} and A_i , say p and q respectively. If x and y have a common neighbor in A_{i-2} , say r , then, by Lemma 3.4:(ii), $\{q, x, r, p, y\}$ induces a 4-wheel, a contradiction; so there is a vertex, say $w \in A_{i-2}$ such that $yw \in E(G)$ and $xw \notin E(G)$. Then by Lemma 3.4:(v), $\{x\}$ is complete to A_{i+2} . Now pick any neighbor of y in A_{i+2} , say s . Then, by Lemma 3.4:(ii), $\{p, q, x, s, w, y\}$ induces a 5-wheel, a contradiction. So Y_{i+1} is anticomplete to X_i . Likewise, Y_{i+1} is anticomplete to X_{i+2} . This proves Lemma 3.22:(ii). ■

(iii): Suppose not. Let $x \in X_i$ and, up to symmetry, let $y \in Y_{i+2}$. Pick any neighbor of y in A_{i-1} , say p . It follows from Lemma 3.4:(iii) and Lemma 3.10:(ii) that x and y have a common neighbor in A_{i-2} , say a . Now if $xy \in E(G)$, then for any neighbor of y in A_i , say a' , by Lemma 3.4:(ii), $\{p, a, x, a', y\}$ induces a 4-wheel, a contradiction; so we may assume that $xy \notin E(G)$. Then pick a neighbor of y in A_{i+1} , say b , and a neighbor of x in A_{i+2} , say b' ; but then $\{p, y, b, b', x\}$ induces a P_5 which is a contradiction. So Lemma 3.22:(iii) holds. ■

(iv): We prove the first assertion, and the proof of the other is similar. Suppose $y \in Y_{i+1}$ and $x \in X_i$. By Lemma 3.4:(ii), $\{x\}$ is complete to A_i , and so by the definition of Y_{i+1} , x and y have a common neighbor in A_i . By Lemma 3.22:(ii), we know that $yx \notin E(G)$. Now x and y have a common neighbor in each A_{i+2} and A_{i-2} , by Observation 1. This proves Lemma 3.22:(iv). ■

(v): Let $x \in X_i$. Let $y \in Y_{i+1}$ and $a \in A_i$, and suppose y and a are non-adjacent. By Lemma 3.22:(ii), $xy \notin E(G)$, and by Lemma 3.22:(iv), x and y have a common neighbor in A_{i-2} , say a' . Then by Lemma 3.4:(ii), $\{y, a', x, a, v_{i+1}\}$ induces a P_5 , a contradiction. So Y_{i+1} is complete to A_i . Likewise, Y_{i-1} is complete to A_i . This proves Lemma 3.22:(v). ■

(vi): Suppose not. We may assume that there are adjacent vertices, say $y \in Y_i$ and $y' \in Y_{i+2}$. Since $Y_i, Y_{i+2} \neq \emptyset$, by Lemma 3.22:(iii), $X_j = \emptyset$, for $j \neq i+1$. Now we claim that $X_{i+1} = \emptyset$. Suppose not. Let $x \in X_{i+1}$. Then by Lemma 3.22:(ii), $\{y, y'\}$ is anticomplete to $\{x\}$, and by Lemma 3.22:(v), $\{y, y'\}$ is complete to $\{v_{i+1}\}$. If y and y' have a common neighbor in A_{i-2} , say a , then for any neighbor of y in A_{i+2} , say a' , $\{a, a', v_{i+1}, y', y\}$ induces a 4-wheel, a contradiction. So we may assume that y and y' do not share a common neighbor in A_{i-2} . Now by Lemma 3.22:(iv), x and y have a common neighbor in A_{i-2} , say p . But then for any neighbor of y' in A_i , say q , we see that $\{x, p, y, y', q\}$ induces a P_5 , a contradiction; so $X_{i+1} = \emptyset$. Thus we conclude that $X = \emptyset$, a contradiction to our assumption that $X \neq \emptyset$. So Lemma 3.22:(vi) holds. ■

(vii): We prove the assertion for $i = 1$. If some vertex in T , say t , has neighbors in both Y_2 and Y_5 , say y and y' , respectively. Then by Lemma 3.22:(vi), $yy' \notin E(G)$. Now pick a neighbor of y in A_5 , say a , and a neighbor of y' in A_2 , say a' , and then $\{a, y, t, y', a'\}$ induces a P_5 , a contradiction. So Lemma 3.22:(vii) holds. □

For $i \in [5]$, if $Y_i \cup Y_{i+2} \neq \emptyset$ and if there is a vertex in each A_{i+1} -clique which is complete to $Y_i \cup Y_{i+2}$, then we pick one such vertex, and let \mathbb{A}_{i+1} be the union of those vertices; otherwise, we

let $\mathbb{A}_{i+1} := R_{A_{i+1}}$. (In any case, \mathbb{A}_{i+1} is a maximum independent set of A_{i+1} .)

Lemma 3.23 *The set $\mathbb{A}_{i-1} \cup \mathbb{A}_{i-2}$ meets each maximal clique of G in $G[A_{i-1} \cup A_{i-2} \cup Y_i \cup Y_{i+1}]$ twice. Likewise, $\mathbb{A}_{i+1} \cup \mathbb{A}_{i+2}$ meets each maximal clique of G in $G[A_{i+1} \cup A_{i+2} \cup Y_i \cup Y_{i-1}]$ twice.*

Proof. By Lemma 3.20:(iv) and Lemma 3.20:(v), $Y_i \cup Y_{i+1}$ is a clique. Also, we know that $Y_i \cup Y_{i+1}$ is complete to B_{i-2} , and anticomplete to $A_{i-2} \setminus B_{i-2}$. Also, Y_{i+1} is complete to B_{i-1} , and anticomplete to $A_{i-1} \setminus B_{i-1}$. Let M be a maximal clique in $G[A_{i-2} \cup A_{i-1} \cup Y_i \cup Y_{i+1}]$. If M has no vertex from Y_i , clearly the assertion holds. So $M \cap Y_i \neq \emptyset$. If M has no vertex from Y_{i+1} , then M is of the form $Y_i \cup B_{i-2} \cup D_{i-1}$, where D_{i-1} is a subset of some A_{i-1} -clique A^* , and is the set of vertices in A^* which are complete to Y_i (by Lemma 3.22:(i)). Since $\mathbb{A}_{i-2} \cup \mathbb{A}_{i-1}$ contains vertices from both B_{i-2} and D_{i-1} , the claim holds. Finally, if $M \cap Y_{i+1} \neq \emptyset$, then by Lemma 3.20:(v), M is of the form $Y_i \cup Y_{i+1} \cup B_{i-2} \cup D_{i-1}$, where D_{i-1} is a subset of B_{i-1} , and is the set of vertices in B_{i-1} which are complete to Y_i (by Lemma 3.22:(i)). So again, as earlier, $\mathbb{A}_{i-2} \cup \mathbb{A}_{i-1}$ meets M twice. This proves Lemma 3.23. \square

Lemma 3.24 *If Y is non-empty, and X is empty, then G is either a nice graph or a quasi-line graph.*

Proof. Since X is empty, by Lemma 3.20:(vi), $T = \emptyset$. Now:

3.24.1 *If there is an $i \in [5]$ such that Y_i and Y_{i+2} are not complete to A_{i+1} , then A_i is a clique, for all $i \in [5]$.*

Proof of 3.24.1. Since Y_i is not complete to A_{i+1} , by Lemma 3.10:(ii), A_{i+1} is a clique, and by Lemma 3.20:(iii), $A_{i+2} \cup A_{i-2}$ is a clique. Likewise, since Y_{i+2} is not complete to A_{i+1} , by Lemma 3.20:(iii), $A_{i-1} \cup A_i$ is a clique. Thus we conclude that A_i is a clique, for all i . This proves 3.24.1. \blacksquare

3.24.2 *If A_i is a clique, for all $i \in [5]$, then G is $3K_1$ -free.*

Proof of 3.24.2. Suppose that G contains a $3K_1$ with vertex-set, say $\{u, v, w\}$. Since $G[A]$ is $3K_1$ -free, we may assume that $u \in Y_j$, for some j . Then by Lemma 3.10:(iii) and Lemma 3.20:(i), $\{u\}$ is complete to either $A_{j+1} \cup A_{j+2} \cup A_{j-2}$ or $A_{j+2} \cup A_{j-1} \cup A_{j-2}$; we may assume, without loss of generality, that $\{u\}$ is complete to $A_{j+1} \cup A_{j+2} \cup A_{j-2}$. Since $A_j \cup A_{j-1} \cup Y_{j+2}$ is a clique (by Lemma 3.20:(i)), and since Y_j is complete to $Y_{j+1} \cup Y_{j-1}$ (by Lemma 3.20:(v)), one of v, w belongs to Y_{j-2} ; and we may assume that $v \in Y_{j-2}$. Then by Lemma 3.20:(i), $\{v\}$ is complete to $A_j \cup A_{j+1}$. So $w \in A_{j-1}$. But then for any neighbor of u in A_{j-2} , say a , and for any neighbor of v in A_j , say b , we see that $\{u, a, w, b, v\}$ induces a P_5 , a contradiction. So 3.24.2 holds. \blacksquare

First suppose that there is an $i \in [5]$ such that Y_i is not anticomplete to Y_{i+2} . Let $y \in Y_i$ and $y' \in Y_{i+2}$ be adjacent. Suppose y and y' share a common neighbor in A_{i+1} , say a . We know, by Lemma 3.10:(ii) and Lemma 3.20:(i), that y and y' share a common neighbor in A_{i-1} , say a' . Then

for a neighbor of y' in A_i , say a'' , $\{a, y, a', a'', y'\}$ induces a 4-wheel, a contradiction; so suppose that y and y' do not share a common neighbor in A_{i+1} . Thus y and y' are not complete to A_{i+1} , hence Y_i and Y_{i+2} are not complete to A_{i+1} . Then by 3.24.1, A_i is a clique for all $i \in [5]$, and then, by 3.24.2, G is $3K_1$ -free. So, by Lemma 3.1, G is either a quasi-line graph or a nice graph, and we are done.

Next we may assume that for each $i \in [5]$, Y_i is anticomplete to $Y_{i+2} \cup Y_{i-2}$. By Lemma 3.20:(v), Y_i is complete to $Y_{i+1} \cup Y_{i-1}$. See Figure 13:(c) for a sketch of G . Also, we may assume that if Y_i and Y_{i+2} are non-empty, then at least one of Y_i, Y_{i+2} is complete to A_{i+1} (for, otherwise, by 3.24.1 and 3.24.2, G is $3K_1$ -free, and we conclude using Lemma 3.1). Now we define three sets $S_1 := A_1 \cup A_3$, $S_2 := A_2 \cup A_4$ and $S_3 := A_5$. Then S_1, S_2 and S_3 are stable sets. Clearly, for $i \in [5]$, by Lemma 3.20:(iv) and Lemma 3.21, $A_{i+2} \cup A_{i-2}$ meets each maximal clique of G in $G[Y_i \cup A_{i+2} \cup A_{i-2}]$ twice, and by Lemma 3.23, $A_{i+1} \cup A_{i+2}$ meets each maximal clique of G in $G[Y_i \cup Y_{i-1} \cup A_{i+1} \cup A_{i+2}]$ twice. So we conclude that $S_1 \cup S_2 \cup S_3$ meets each maximum clique of G at least twice, and meets other maximal cliques of G at least once, and hence G is nice. This completes the proof of Lemma 3.24. \square

Now we prove our main result of this subsection, and is given below.

Theorem 3.25 *If a connected (P_5, wheel) -free atom G contains a C_5 , then G is either a nice graph or a quasi-line graph.*

Proof. Let G be a connected (P_5, wheel) -free atom that contains a C_5 , say with vertex-set $\{v_1, v_2, v_3, v_4, v_5\}$ and the edge-set $\{v_1v_2, v_2v_3, v_3v_4, v_4v_5, v_5v_1\}$. Then we define the sets A, X, Y, Z and T as in Section 3.3 with $v_i \in A_i$, for each i , and we use the lemmas in Section 3.3, and properties in Lemmas 3.16 and 3.17 and Lemmas 3.20 to 3.23. Since $Z = \emptyset$, if $T \neq \emptyset$, then $G[T]$ is P_3 -free (by Lemma 3.10:(v)). Let \mathcal{M} be the set of maximum cliques of G . Let L be the set that consist of one vertex from each T -clique, otherwise let $L := \emptyset$, and let L' be the set that consist of one vertex (which is not in L) from each non-trivial T -clique, otherwise let $L' := \emptyset$. By Lemma 3.8, for $j \in [5]$, if $X_j, X_{j+1} \neq \emptyset$, $R_{X_j} \cup R_{X_{j+1}} \cup R_{A_{j-2}}$ meets each maximal clique of G in $G[X_j \cup X_{j+1} \cup A_{j-2}]$ at least twice. Now if $X \cup Y = \emptyset$, then since G is connected, by Lemma 3.20:(vi), $T = \emptyset$, and then the sets $S_1 := R_{A_1} \cup R_{A_3}$, $S_2 := R_{A_2} \cup R_{A_4}$ and $S_3 := R_{A_5}$ are the desired stable sets, and we are done. If one of X, Y is empty, then the theorem follows from Lemmas 3.19 and 3.24. So we may assume that both X and Y are non-empty. Now if $Y_{i+1} \neq \emptyset$, then by Lemma 3.4:(iii) and Lemma 3.22:(iv), X_i is complete to B_{i-2} , and X_{i+2} is complete to B_{i-1} . Recall that since $X \neq \emptyset$, by Lemma 3.22:(vi), Y_i is anticomplete to $Y_{i+2} \cup Y_{i-2}$. Now we split the proof into two cases.

Case 1 *For each $i \in [5]$, one of X_i, Y_i is empty.*

Since $Y \neq \emptyset$, let $Y_2 \neq \emptyset$; so $X_2 = \emptyset$. By Lemma 3.22:(iii), $X_4 \cup X_5 = \emptyset$. Since $X \neq \emptyset$, $X_1 \cup X_3 \neq \emptyset$; we may assume that $X_1 \neq \emptyset$; so $Y_1 = \emptyset$. Again by Lemma 3.22:(iii), $Y_3 \cup Y_4 = \emptyset$.

By Lemma 3.22:(v), $Y_2 \cup Y_5$ is complete to A_1 . By Lemma 3.22:(ii), $Y_2 \cup Y_5$ is anticomplete to $X_1 \cup X_3$. Recall that Y_2 is complete to $B_4 \cup B_5$, and anticomplete to $(A_4 \setminus B_4) \cup (A_5 \setminus B_5)$, and since $Y_2 \neq \emptyset$, X_1 is complete to B_4 . Moreover, we have the following:

3.25.1 *If $T \neq \emptyset$, then the following hold: (a) T is complete to Y_2 . (b) For $j \in \{1, 3\}$, given an X_j -clique, say X_j^* , each T -clique is either complete or anticomplete to X_j^* . (c) $Y_5 = \emptyset$.*

Proof of 3.25.1. (a): Let T' be a T -clique in G . Then by Lemma 3.20:(vi), $N(T') \cap (X_1 \cup X_3) \neq \emptyset$. Since Y_2 is anticomplete to $X_1 \cup X_3$ (by Lemma 3.22:(ii)), it follows from Lemma 3.11:(i) that T' is complete to Y_2 . This proves (a), since T' is arbitrary.

(b): Since Y_2 is anticomplete to $X_1 \cup X_3$, (b) follows from (a), Lemma 3.11:(ii) and Lemma 3.20:(vi).

(c): Suppose that $Y_5 \neq \emptyset$. Then, by Lemma 3.22:(iii), $X_3 = \emptyset$. Let $t \in T$. Then by Lemma 3.20:(vi), t has a neighbor in X_1 . Since $Y_2 \cup Y_5$ is anticomplete to X_1 (by Lemma 3.22:(ii)), it follows from Lemma 3.11 that t has neighbors in both Y_2 and Y_5 which is a contradiction to Lemma 3.22:(vii). This proves (c). ■

3.25.2 *If $T \neq \emptyset$, then Y_2 is complete to either A_4 or A_5 . So, if $T \neq \emptyset$, either A_4 or A_5 is a clique.*

Proof of 3.25.2. Suppose not. Then there are vertices, say $y \in Y_2$, $p \in A_4$ and $q \in A_5$ such that $yp, yq \notin E(G)$. Let $t \in T$. Then by 3.25.1:(a), $yt \in E(G)$. But then since Y_2 is complete to A_1 , for any neighbor of y in A_1 , say r , we see that $\{p, q, r, y, t\}$ induces a P_5 , a contradiction. So the first assertion of 3.25.2 holds. The second assertion of 3.25.2 follows from the first assertion of 3.25.2 and Lemma 3.21. ■

3.25.3 *If K is an X_1 -clique and D is an A_3 -clique, then either K is complete to D or K is anticomplete to D . Likewise, if K' is an X_3 -clique and D' is an A_1 -clique, then either K' is complete to D' or K' is anticomplete to D' .*

Proof of 3.25.3. Suppose that K is not anticomplete to D . Then, there is an $x \in K$ which has a neighbor in D . Let $a \in D$ be such that $a \in A_3$ (such a vertex exists, by Lemma 3.22:(i)). Then by Lemma 3.4:(iii), $\{x\}$ is complete to D ; so $xa \in E(G)$. Let $x' (\neq x) \in K$ be arbitrary. We claim that $\{x'\}$ is complete to D . Suppose not. Then again by Lemma 3.4:(iii), $\{x'\}$ is anticomplete to D ; so $x'a \notin E(G)$. But then, for any $y \in Y_2$ and $b \in B_5$, $\{x', x, a, y, b\}$ induces a P_5 , a contradiction. So $\{x'\}$ is complete to D . Since x' is arbitrary, K is complete to D . This proves 3.25.3. ■

3.25.4 *If K is an X_1 -clique and D is an A_4 -clique, then either K is complete to D or K is anticomplete to D . Likewise, if K' is an X_3 -clique and D' is an A_5 -clique, then either K' is complete to D' or K' is anticomplete to D' .*

Proof of 3.25.4. Suppose that K is not anticomplete to D . We may assume that $D \neq B_4$. Then, there is an $x \in K$ which has a neighbor in D , say a . Let $x' (\neq x) \in K$ be arbitrary. We claim

that $\{x'\}$ is complete to D . Suppose not. Then, by Lemma 3.4:(iii), $\{x'\}$ is anticomplete to D ; so $x'a \notin E(G)$. But then, for any $y \in Y_2$ and $b \in B_5$, $\{x', x, a, b, y\}$ induces a P_5 , a contradiction. So $\{x'\}$ is complete to D . Since x' is arbitrary, K is complete to D . This proves 3.25.4. ■

Now consider any maximum clique of G in $G[X_i \cup A_{i+2} \cup A_{i-2}]$, say M . Then by 3.25.3 and 3.25.4, $M \cap A_{i+2}, M \cap A_{i-2} \neq \emptyset$, $M \cap A_{i+2}$ is an A_{i+2} -clique and $M \cap A_{i-2}$ is an A_{i-2} -clique.

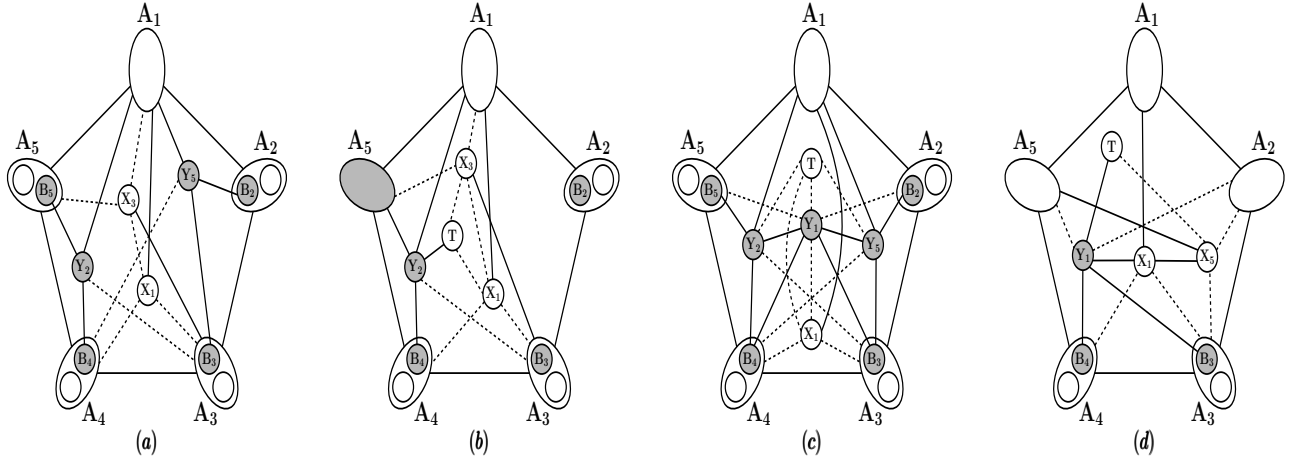

Figure 14: Sketch of the graph G in Theorem 3.25: (a) Case 1 when $T = \emptyset$. (b) Case 1 when $T \neq \emptyset$. (c) Case 2 when $X_2 \cup X_5 = \emptyset$. (d) Case 2 when $X_5 \neq \emptyset$.

See Figure 14:(a) and Figure 14:(b). By Lemma 3.16:(ii) and 3.25.3, we conclude that each X_1 -clique is either complete or anticomplete to K , where K is an A_3 -clique or an X_3 -clique. Likewise, each X_3 -clique is either complete or anticomplete to K' , where K' is an A_1 -clique or an X_1 -clique. Thus, by Lemma 3.4:(ii) and Observation 3, for $j \in \{1, 3\}$, $R_{X_1} \cup R_{X_3} \cup R_{A_j}$ meets each maximal clique of G in $G[X_1 \cup X_3 \cup A_j]$ at least twice. Also, by Lemma 3.16:(ii), 3.25.1:(b), and by Observation 3, $R_{X_1} \cup R_{X_3} \cup R_T$ meets each maximal clique of G in $G[X_1 \cup X_3 \cup T]$ at least twice. Clearly $R_{A_1} \cup R_{A_5}$ meets each maximal clique of G in $G[Y_2 \cup A_1 \cup A_5]$ twice. Likewise, $R_{A_1} \cup R_{A_2}$ meets each maximal clique of G in $G[Y_5 \cup A_1 \cup A_2]$ twice.

Now if $T = \emptyset$, then using Lemma 3.17:(i) and by Lemma 3.23, we see that the sets $S_1 := R_{A_2} \cup R_{A_5} \cup R_{X_1}$, $S_2 := R_{A_1} \cup A_3$ and $S_3 := A_4 \cup R_{X_3}$ are the desired stable sets. So we may assume that $T \neq \emptyset$. By 3.25.1, $Y_5 = \emptyset$. By 3.25.2, up to relabeling, we may assume that A_5 is a clique. Now we let $S_1 := R_{A_2} \cup R_{A_5} \cup R_{X_1}$, $S_2 := R_{A_1} \cup A_3 \cup R_T$ and $S_3 := R_{A_4 \setminus B_4} \cup R_{X_3} \cup R_{Y_2}$. Clearly, S_1, S_2 and S_3 are stable sets. Let $S := S_1 \cup S_2 \cup S_3$. To justify that S meets each maximum clique of G that has vertices from $A_3 \cup B_4$, at least twice, we need the following.

3.25.5 *If $M \in \mathcal{M}$ has vertices from both B_4 and an A_3 -clique A_3^* , and no vertex from Y_2 , then M is of the form $X_1^* \cup B_4 \cup A_3^*$, where X_1^* is an X_1 -clique, and $B_4 \cup A_3^* \notin \mathcal{M}$.*

Proof of 3.25.5. If X_1^* is complete to A_3^* , then M is of the form $X_1^* \cup B_4 \cup A_3^*$, and we are done. So, we may assume, by 3.25.3, that X_1^* is anticomplete to A_3^* . Then, by Lemma 3.4:(iii), A_3 is not a

clique, and then by Lemma 3.10:(ii), A_3 is complete to Y_2 . But now since $Y_2 \cup B_4 \cup A_3^*$ is a larger clique than $B_4 \cup A_3^*$, we have $B_4 \cup A_3^* \notin \mathcal{M}$. This proves 3.25.5. ■

Now by Lemma 3.17:(i) and 3.25.5, $R_{X_1} \cup R_{A_4 \setminus B_4} \cup R_{A_3}$ meets each maximum clique of G in $G[X_1 \cup A_3 \cup A_4]$ twice. Clearly, $R_{A_5} \cup R_{Y_2}$ meets each maximum clique of G in $G[Y_2 \cup B_4 \cup A_5]$ twice, $A_3 \cup R_{Y_2}$ meets each maximum clique of G in $G[Y_2 \cup A_3 \cup A_4]$ twice (by Lemma 3.23), $R_{A_5} \cup R_{A_4 \setminus B_4}$ meets each maximum clique of G in $G[(A_4 \setminus B_4) \cup A_5]$, and $R_{Y_2} \cup R_T$ meets each maximum clique of G in $G[Y_2 \cup T]$ twice. Thus, we conclude that S meets each maximum clique of G at least twice, and meets other maximal cliques of G at least once, and that G is nice.

Case 2 *There is an index $i \in [5]$ such that X_i and Y_i are non-empty.*

Let $i = 1$. Then by Lemma 3.22:(iii), $X_3 \cup X_4 \cup Y_3 \cup Y_4 = \emptyset$. Recall that Y_1 is anticomplete to $X_2 \cup X_5$ (by Lemma 3.22:(ii)), and complete to $Y_2 \cup Y_5$ (by Lemma 3.20:(v)). Also X_1 is complete to $X_2 \cup X_5$ (by Lemma 3.5:(v)). By Lemma 3.21, $Y_1 \cup Y_2$ is complete to B_4 , and anticomplete to $A_4 \setminus B_4$; $Y_1 \cup Y_5$ is complete to B_3 , and anticomplete to $A_3 \setminus B_3$. Also, by Lemma 3.4:(iii) and Lemma 3.22:(iv), X_2 is complete to B_4 , and X_5 is complete to B_3 . Note that since $Y_1 \neq \emptyset$, $B_3, B_4 \neq \emptyset$. Since $X_1 \neq \emptyset$, by Lemma 3.22:(v), $Y_2 \cup Y_5$ is complete to A_1 . Recall that since $Z = \emptyset$, each vertex in $X \cup Y$ is either anticomplete to T or good with respect to T . By Lemma 3.17:(iii), $R_{X_i} \cup R_{A_{i+2}} \cup R_{A_{i-2}}$ meets each maximum clique of G in $G[X_i \cup A_{i+2} \cup A_{i-2}]$ twice, and meets other maximal cliques in $G[X_i \cup A_{i+2} \cup A_{i-2}]$ once. To proceed further we claim following:

3.25.6 *Suppose $x \in X_1$ has a neighbor in $(A_3 \setminus B_3) \cup (A_4 \setminus B_4)$. Then $\{x\}$ is complete to Y_1 .*

Proof of 3.25.6. We may assume, up to symmetry, that x has a neighbor in $A_3 \setminus B_3$, say p . Let $y \in Y_1$, and suppose x and y are non-adjacent. Now pick a neighbor of y in A_5 , say a . Then for any $a' \in A_1$, by Lemma 3.4:(ii), $\{p, x, a', a, y\}$ induces a P_5 , a contradiction. So 3.25.6 holds. ■

3.25.7 *Let M be a maximal clique of G containing at least one vertex from each of X_1 and Y_1 , and no vertex from T . Then $R_{B_3} \cup R_{B_4} \cup R_{X_1}$ meets M at least twice.*

Proof of 3.25.7. Let $M \cap X_1 = X_1^*$ and let D be the X_1 -clique such that $X_1^* \subseteq D$. Recall that Y_1 is complete to $B_3 \cup B_4$. Now we claim that D is complete to either B_3 or B_4 . Suppose not. Then by Lemma 3.4:(iv) and Lemma 3.4:(v), there are vertices, say $x, x' \in D$ such that $\{x\}$ is anticomplete to B_3 , and $\{x'\}$ is anticomplete to B_4 . Then by the definition of X_1 , x has a neighbor in $A_3 \setminus B_3$, and x' has a neighbor in $A_4 \setminus B_4$. So, by 3.25.6, $\{x, x'\}$ is complete to Y_1 . Then by 3.25.6 and Lemma 3.4:(v), for any $y \in Y_1$, $b \in B_3$ and $b' \in B_4$ then $\{x, b', b, x', y\}$ induces a 4-wheel, a contradiction; so D is complete to either B_3 or B_4 . Now since M is a maximal clique and X_1^* is either complete to B_3 or B_4 , we conclude that $M \cap (B_3 \cup B_4) \neq \emptyset$. If X_1^* is complete to $B_3 \cup B_4$, then clearly the assertion holds. So we assume that X_1^* is not complete to B_4 , then there is an $x \in X_1^*$ such that $\{x\}$ is anticomplete to B_4 (by Lemma 3.4:(iii)). So by a previous argument, D is complete to B_3 . Next we claim that D is complete Y_1 . Suppose there are vertices, say $x' \in D$

and $y \in Y_1$ such that $x'y \notin E(G)$. By 3.25.6, $x \neq x'$, and $\{x'\}$ is anticomplete to $A_4 \setminus B_4$, so by the definition of X_1 , x' must have a neighbor in B_4 . Then by 3.25.6 and Lemma 3.4:(iv), for any $a \in B_3$ and $a' \in B_4$, $\{a', x', x, y, a\}$ induces a 4-wheel, a contradiction. So D is complete to Y_1 . Since $B_3 \cup D \cup Y_1$ is a clique and M is a maximal clique, we have $X_1^* = D$ and hence $M = B_3 \cup D \cup Y_1$. Then clearly $R_{B_3} \cup R_{B_4} \cup R_{X_1}$ meets M at least twice. This proves 3.25.7. ■

3.25.8 *Suppose that $X_2 \cup X_5 = \emptyset$, and let Q be a T -clique. If there is an $M \in \mathcal{M}$ such that $Q \subseteq M$, then $|Q| \geq 2$.*

Proof of 3.25.8. Recall that each vertex in $X \cup Y$ is either complete or anticomplete to Q . For $j \in \{1, 2, 5\}$, let $Y_j^* := N(Q) \cap Y_j$. First suppose that $(M \setminus Q) \cap X = \emptyset$. If $M \setminus Q = Y_1^* \cup Y_2^*$, then $|Y_1^* \cup Y_2^* \cup Q| \geq |B_4 \cup Y_1 \cup Y_2 \cup \{b_3\}|$, where $b_3 \in B_3$ is the vertex such that $\{b_3\}$ is complete to Y_2 (by Lemma 3.22:(i)), hence $|Q| \geq 2$. Likewise, if $M \setminus Q = Y_1^* \cup Y_5^*$, then $|Q| \geq 2$. So we assume that $(M \setminus Q) \cap X \neq \emptyset$. Then $M \setminus Q = X_1^* \cup Y_1^*$ where X_1^* is a subset of some X_1 -clique such that $N(Q) \cap X_1^* \neq \emptyset$. Then by Lemma 3.5:(iii), X_1^* is complete to $A_3 \cup A_4$; in particular X_1^* is complete to $B_3 \cup B_4$. So $|X_1^* \cup Y_1^* \cup Q| \geq |B_3 \cup B_4 \cup X_1^* \cup Y_1^*|$, thus $|Q| \geq 2$. This proves 3.25.8. ■

First suppose that $X_2 \cup X_5 = \emptyset$, and we apply 3.25.8. We refer to Figure 14:(c) for a sketch of the graph G . Then, by Lemma 3.23, $\cup_{i=1}^5 \mathbb{A}_i$ meets each maximum clique of G in $G[A \cup Y]$ twice. Since X_1 is anticomplete to $Y_2 \cup Y_5$, by 3.25.7, and by Lemma 3.23, $\mathbb{A}_3 \cup \mathbb{A}_4 \cup R_{X_1}$ meets each maximum clique of G in $G[X \cup Y \cup A_3 \cup A_4]$ twice, and clearly, by Lemma 3.4:(ii), $\mathbb{A}_1 \cup R_{X_1}$ meets each maximum clique of G in $G[X_1 \cup A_1]$ twice. Then since each vertex in $X \cup Y$ is either complete or anticomplete to a T -clique, by 3.25.8, we conclude that $S_1 := \mathbb{A}_2 \cup \mathbb{A}_5 \cup R_{X_1}$, $S_2 := \mathbb{A}_1 \cup \mathbb{A}_4 \cup L$ and $S_3 := \mathbb{A}_3 \cup L'$ are the required stable sets.

Next suppose that $X_2 \cup X_5 \neq \emptyset$. We may assume, up to symmetry, that $X_5 \neq \emptyset$. Then, by Lemma 3.22:(iii), $Y_2 = \emptyset$. Next we claim that X_1 is complete to Y_1 . Suppose to the contrary that there are non-adjacent vertices, say $x \in X_1$ and $y \in Y_1$. Then, by 3.25.6, $\{x\}$ is complete to $B_3 \cup B_4$. Now pick any $x' \in X_5$, $a \in B_3$, $a' \in B_4$, and pick a common neighbor of x' and y in A_2 , say a'' (by Lemma 3.22:(iv)). Then since X_5 is complete to B_3 , we see that $\{y, a', x, x', a'', a\}$ induces a 5-wheel, a contradiction; so X_1 is complete to Y_1 . Further, if there are adjacent vertices, say $x \in X_1$ and $b \in B_3$, then for any $x' \in X_5$, $y \in Y_1$, by Lemma 3.22:(iv), x' and y have a common neighbor in A_2 , say a , and then, by Lemma 3.5:(v), $\{x, y, a, x', b\}$ induces a 4-wheel, a contradiction; so X_1 is anticomplete to B_3 . Likewise, if $X_2 \neq \emptyset$, then X_1 is anticomplete to B_4 , a contradiction to Lemma 3.4:(v); so $X_2 = \emptyset$. Since X_1 is anticomplete to B_3 , by Lemma 3.22:(iv), $Y_5 = \emptyset$, and by Lemma 3.5:(iii), X_1 is anticomplete to T . By Lemma 3.20:(vi), each vertex in T has a neighbor in X_5 , and so by Lemma 3.11, T is complete to Y_1 . Hence again by Lemma 3.11, each T -clique is either complete or anticomplete to an X_5 -clique. See Figure 14:(d) for a sketch of the graph G . Moreover, if there is a $M \in \mathcal{M}$ which has vertices from a T -clique T^* and from Y_1 , then $|Y_1 \cup T^*| \geq |Y_1 \cup B_3 \cup B_4|$, and so $|T^*| \geq 2$. Now we let $S_1 := \mathbb{A}_2 \cup \mathbb{A}_5 \cup R_{X_1} \cup L$, $S_2 := R_{A_1} \cup R_{A_4} \cup R_{X_5}$ and $S_3 := R_{A_3} \cup L'$. Then $R_{X_5} \cup L \cup L'$ meets each maximum clique of G in

$G[X \cup Y \cup T]$ at least twice, and meets other maximal cliques once. Also, by 3.25.7, $R_{A_3} \cup R_{A_4} \cup R_{X_1}$ meets each maximum clique of G in $G[X_1 \cup Y_1 \cup A_3 \cup A_4]$ twice, and meets other maximal cliques once. By Lemma 3.8, $R_{X_1} \cup R_{X_5} \cup R_{A_3}$ meets each maximal clique of G in $G[X_1 \cup X_5 \cup A_3]$ at least twice. Now by using Lemma 3.23, we observe that $S_1 \cup S_2 \cup S_3$ meets each maximum clique of G at least twice, and meets other maximal cliques at least once. So G is nice. This completes the proof of Theorem 3.25. \square

3.4.3 Structure of $(P_5, C_5, 4\text{-wheel})$ -free graphs that contain a $\overline{C_7}$

Let C^* be the $\overline{C_7}$ with vertices v_1, v_2, \dots, v_7 and edges $v_i v_{i+1}$ and $v_i v_{i+2}$ for each i modulo 7. Let H^* be the graph obtained from C^* by adding two vertices v_8 and v_9 and edges $v_8 v_1, v_8 v_2, v_8 v_5, v_9 v_5, v_9 v_6$ and $v_9 v_2$.

Theorem 3.26 *If a connected $(P_5, C_5, 4\text{-wheel})$ -free graph G contains a $\overline{C_7}$, then G is a P_3 -free expansion of H^* , and hence G is nice.*

Proof. For convenience, we consider the complement graph of G , say H . So H is a $(\overline{P_5}, C_5, 2K_2 + K_1)$ -free graph such that \overline{H} ($\cong G$) is connected, and contains a C_7 , say with vertex-set $\{u_1, u_2, \dots, u_7\}$ and the edge-set $\{u_1 u_2, u_2 u_3, \dots, u_6 u_7, u_7 u_1\}$. So we may assume that there are seven non-empty and pairwise disjoint sets A_1, \dots, A_7 such that for each i modulo 7 the set A_i is complete to $A_{i-1} \cup A_{i+1}$, and anticomplete to $A_{i-2} \cup A_{i-3} \cup A_{i+2} \cup A_{i+3}$ and let $u_i \in A_i$. Let $A := A_1 \cup \dots \cup A_7$. We choose these sets such that A is maximal. For each $i \in [7]$, let B_i denote the set $\{x \in V(H) \setminus A \mid x \text{ has a neighbor in each } A_j, j \in \{i, i+1, i+2, i+3\}\}$, and $\{x\}$ is anticomplete to $A_{i-1} \cup A_{i-2} \cup A_{i-3}$. Let $B := B_1 \cup \dots \cup B_7$. Let D denote the set $\{x \in V(H) \setminus A \mid x \text{ has a neighbor in } A_i, \text{ for each } i \in [7]\}$. Moreover, the following hold, for each $i \in [7]$:

3.26.1 *Let P be a P_4 in H , say with vertex-set $\{a_1, a_2, a_3, a_4\}$ and the edge-set $\{a_1 a_2, a_2 a_3, a_3 a_4\}$. Then any vertex in $V(H) \setminus V(P)$ which is adjacent to both a_1 and a_4 , is adjacent to both a_2 and a_3 .*

Proof of 3.26.1. If there is a vertex, say $p \in V(H) \setminus V(P)$ such that $a_1 p, a_4 p \in E(G)$ and $\{p\}$ is not adjacent to both a_2 and a_3 , then $\{a_1, a_2, a_3, a_4, p\}$ induces a C_5 or $\overline{P_5}$, a contradiction. So any vertex in $V(H) \setminus V(P)$ which is adjacent to both a_1 and a_4 , is adjacent to both a_2 and a_3 . This proves 3.26.1. \blacksquare

3.26.2 *Each vertex in $V(H) \setminus A$ has a neighbor in A .*

Proof of 3.26.2. If some $x \in V(H) \setminus A$ has no neighbor in A , then $\{u_1, u_2, u_4, u_5, x\}$ induces a $2K_2 + K_1$, a contradiction. So 3.26.2 holds. \blacksquare

3.26.3 *Let $x \in V(H) \setminus (A \cup D)$. Suppose x has a neighbor in A_i . Then exactly one of $N(x) \cap A_{i-2}$, $N(x) \cap A_{i+2}$ is non-empty.*

Proof of 3.26.3. Suppose not, and let $i = 1$. Let a be a neighbor of x in A_1 . If $N(x) \cap A_3 = \emptyset$ and $N(x) \cap A_6 = \emptyset$, then by 3.26.1, $N(x) \cap A_5 = \emptyset$, and then $\{a, x, u_5, u_6, u_3\}$ induces a $2K_2 + K_1$, a contradiction; so we may assume that $N(x) \cap A_3 \neq \emptyset$ and $N(x) \cap A_6 \neq \emptyset$. Then by 3.26.1, $\{x\}$ is complete to $A_4 \cup A_5$. Then, again by using 3.26.1, we see that $\{x\}$ is complete to $A_2 \cup A_7$. But then $x \in D$, a contradiction. So 3.26.3 holds. ■

3.26.4 $V(H) = A \cup B \cup D$.

Proof of 3.26.4. Let $x \in V(H) \setminus (A \cup D)$. Then, by 3.26.2, we may assume that x has a neighbor in A_i , say a_i . By 3.26.3, we may assume that $N(x) \cap A_{i+2} \neq \emptyset$ and $\{x\}$ is anticomplete to A_{i-2} . Then, by 3.26.1, $\{x\}$ is anticomplete to A_{i-3} . Let a_{i+2} be a neighbor of x in A_{i+2} . We claim that x has a neighbor in A_{i+1} . Suppose $\{x\}$ is anticomplete to A_{i+1} . Then, by 3.26.1, $\{x\}$ is anticomplete to $A_{i+3} \cup A_{i-1}$. Also, if x has a non-neighbor, say a'_i , in A_i , then $\{a'_i, u_{i-1}, x, a_{i+2}, u_{i-3}\}$ induces a $2K_2 + K_1$, a contradiction; so $\{x\}$ is complete to A_i . Likewise, $\{x\}$ is complete to A_{i+2} . But then x can be added to A_i , contradicting the maximality of A . So we may assume that x has a neighbor in A_{i+1} , say a_{i+1} . Then by 3.26.1, x has no neighbors in both A_{i+3} and A_{i-1} . But since $\{x, a_{i+1}, u_{i+3}, u_{i-3}, u_{i-1}\}$ does not induce a $2K_2 + K_1$, x has a neighbor in exactly one of A_{i+3} and A_{i-1} , say x has a neighbor in A_{i+3} . So $x \in B_i$. This proves 3.26.4. ■

3.26.5 A_i is a stable set.

Proof of 3.26.5. If there are adjacent vertices in A_i , say p and q , then $\{p, q, u_{i+2}, u_{i+3}, u_{i-2}\}$ induces a $2K_2 + K_1$, a contradiction. So 3.26.5 holds. ■

3.26.6 $H[B_i]$ is $(K_1 + K_2)$ -free.

Proof of 3.26.6. If there is a $K_1 + K_2$ induced by the vertex-set, say $\{p, q, r\}$, in B_i , then $\{u_{i-1}, u_{i-2}, p, q, r\}$ induces a $2K_2 + K_1$, a contradiction. So 3.26.6 holds. ■

3.26.7 B_i is complete to $A_i \cup A_{i+1} \cup A_{i+2} \cup A_{i+3}$.

Proof of 3.26.7. Let $x \in B_i$ and $y \in A_i \cup A_{i+1} \cup A_{i+2} \cup A_{i+3}$, and suppose x and y are non-adjacent. Let a_{i+1} and a_{i+2} be neighbors of x in A_{i+1} and A_{i+2} respectively. By symmetry, we may assume that $y \in A_i \cup A_{i+1}$. Now if $y \in A_i$, then $\{u_{i-1}, y, x, a_{i+2}, u_{i-3}\}$ induces a $2K_2 + K_1$, a contradiction, and if $y \in A_{i+1}$, then, by 3.26.5, $ya_{i+1} \notin E(G)$, and then $\{u_{i-1}, u_{i-2}, x, a_{i+1}, y\}$ induces a $2K_2 + K_1$, a contradiction. So 3.26.7 holds. ■

3.26.8 B_i is complete to $B_{i+1} \cup B_{i-1}$.

Proof of 3.26.8. Let $x \in B_i$ and $y \in B_{i+1} \cup B_{i-1}$, and suppose x and y are non-adjacent. By symmetry, we may assume that $y \in B_{i+1}$. Then by 3.26.7, $\{x, u_{i+1}, y, u_{i+4}, u_{i+3}\}$ induces a $\overline{P_5}$, a contradiction. So 3.26.8 holds. ■

3.26.9 If $B_i \neq \emptyset$, then $B_{i-3} \cup B_{i-2} \cup B_{i+2} \cup B_{i+3}$ is empty.

Proof of 3.26.9. Let $x \in B_i$. Suppose that there is a vertex, say $x' \in B_{i+2}$. If $xx' \in E(G)$, then by 3.26.7, $\{x, u_i, u_{i-1}, u_{i-2}, x', x\}$ induces a C_5 , a contradiction; so $xx' \notin E(G)$, and then, by 3.26.7, $\{x, u_{i+1}, x', u_{i-3}, u_{i-1}\}$ induces a $2K_2 + K_1$, a contradiction. So $B_{i+2} = \emptyset$. Likewise, $B_{i-2} = \emptyset$. Also, if there is a vertex, say $y \in B_{i+3}$, then, by 3.26.7, $\{u_{i-1}, u_i, x, u_{i+3}, y\}$ induces a C_5 or a $\overline{P_5}$, a contradiction. So $B_{i+3} = \emptyset$. Likewise, $B_{i-3} = \emptyset$. This proves 3.26.9. ■

3.26.10 D is complete to $A \cup B$.

Proof of 3.26.10. Suppose there are non-adjacent vertices, say $x \in D$ and $a \in A_i$. Pick neighbors of x in each A_{i+1} , A_{i+2} and A_{i-1} , say p, q , and r respectively. Then $\{a, p, q, r, x\}$ induces a $\overline{P_5}$, a contradiction. So D is complete to A . Next, if there are non-adjacent vertices, say $x \in D$ and $x' \in B_i$, then, by 3.26.7, and by the earlier argument, $\{x', u_i, u_{i-1}, x, u_{i+3}\}$ induces a $\overline{P_5}$, a contradiction. This proves 3.26.10. ■

Now since \overline{H} is connected, we have $D = \emptyset$. So by above properties, if $B = \emptyset$, then G is a clique expansion of $\overline{C_7}$. So we may assume that $B_1 \neq \emptyset$. Then by 3.26.9, $B_3 \cup B_4 \cup B_5 \cup B_6$ is empty, and one of B_2, B_7 is empty. Thus we conclude that G is a P_3 -free expansion of H^* . Let H^* be defined as earlier. By the definition of a expansion, $V(G)$ is partitioned into Q_{v_i} , $v_i \in V(H^*)$, such that each Q_{v_i} induces a P_3 -free graph. Now we let $S_1 := R_{Q_{v_1}} \cup R_{Q_{v_4}} \cup R_{Q_{v_9}}$, $S_2 := R_{Q_{v_2}} \cup R_{Q_{v_5}}$ and $S_3 := R_{Q_{v_3}} \cup R_{Q_{v_7}} \cup R_{Q_{v_8}}$. Clearly S_1, S_2 and S_3 are stable sets such that $S_1 \cup S_2 \cup S_3$ meets each maximal clique of G twice. So G is nice. This completes the proof of Theorem 3.26. □

3.4.4 Main structural results

In this section, we state and prove our main structural decomposition theorem which is useful in proving a near tight chromatic bound for the class of $(P_5, 4\text{-wheel})\text{-free}$ graphs.

Theorem 3.27 *Let G be a connected $(P_5, 4\text{-wheel})\text{-free}$ atom. If G is imperfect, then one of the following holds:*

- (1) *If G contains a 5-wheel, then G is a nice graph.*
- (2) *If G is 5-wheel-free and contains a C_5 , then G is either a nice graph or a quasi-line graph.*
- (3) *If G is C_5 -free and contains a $\overline{C_7}$, then G is a nice graph.*

Proof. Since each k -wheel, for $k \geq 6$ has an induced P_5 , the proof of each of the item in Theorem 3.27 follows from Theorem 3.15, Theorem 3.25 and Theorem 3.26 respectively. □

Theorem 3.28 *If G is a connected $(P_5, 4\text{-wheel})\text{-free}$ atom, then G is either a perfect graph, or a nice graph, or a quasi-line graph.*

Proof. Let G be a connected $(P_5, 4\text{-wheel})\text{-free}$ atom. We may assume that G is imperfect. Then since C_{2k+1} for $k \geq 3$ contains a P_5 , and since $\overline{C_{2k+1}}$ for $k \geq 4$ contains a 4-wheel, from Theorem 1.2, G contains a C_5 ($\cong \overline{C_5}$) or a $\overline{C_7}$. So it satisfies the hypothesis of one of the items of Theorem 3.27 and subsequently it satisfies the conclusion of that item. This proves Theorem 3.28. □

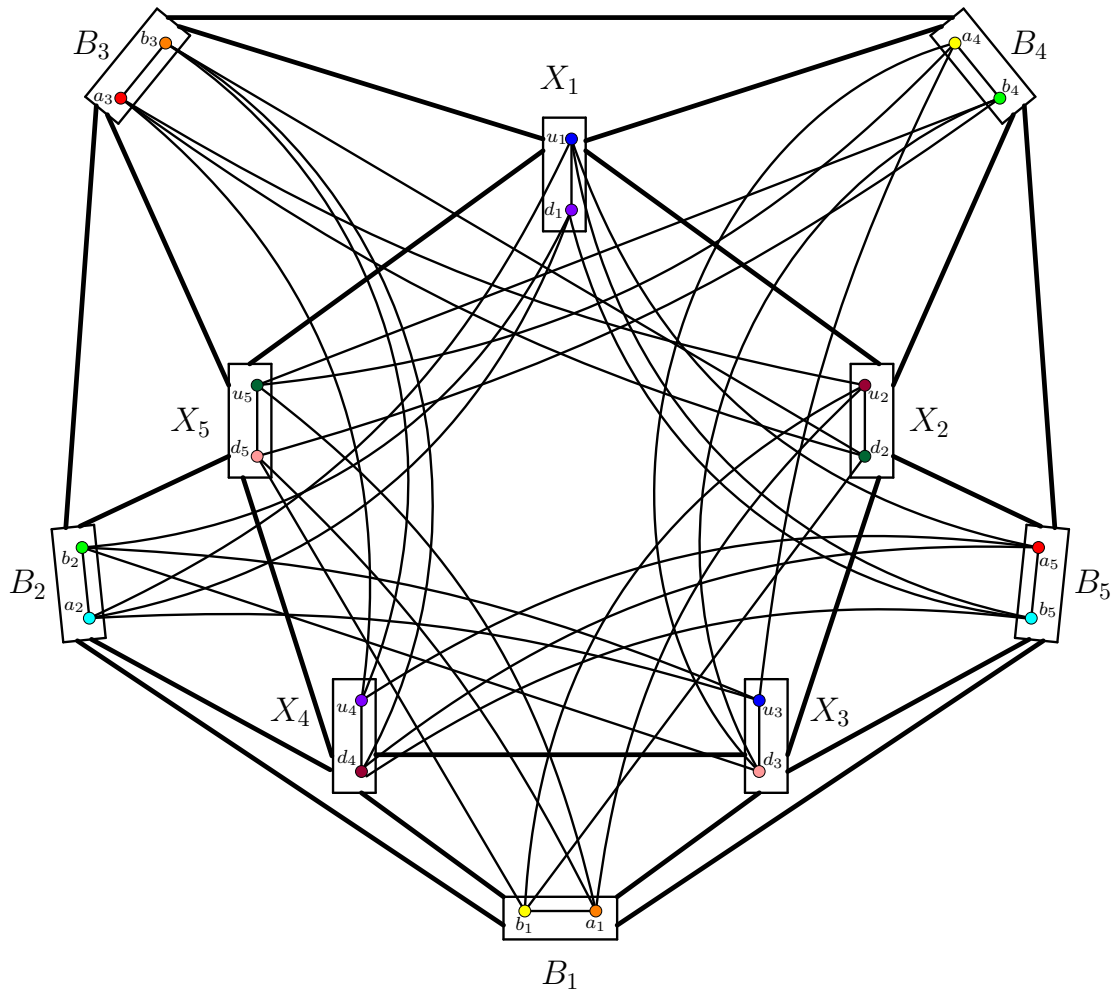

Figure 15: Example of a $(P_5, 4\text{-wheel})$ -free graph G^* with chromatic number 10 and clique number 7 (see also [33]). Here, a bold (or thick) line between two rectangles represents that every vertex inside a rectangle is adjacent to every vertex in the other. For example, the vertex d_3 is adjacent to both a_1 and b_1 . Likewise, u_3 is adjacent to both d_4 and u_4 .

3.5 Chromatic bound for $(P_5, 4\text{-wheel})$ -free graphs

In this section, we prove a nearly tight chromatic bound for the class of $(P_5, 4\text{-wheel})$ -free graphs. Indeed, we prove the following.

Theorem 3.29 *If G is a $(P_5, 4\text{-wheel})$ -free graph, then $\chi(G) \leq \frac{3}{2}\omega(G)$. Moreover, there is a class of $(P_5, 4\text{-wheel})$ -free graphs \mathcal{L} such that every graph $H \in \mathcal{L}$ satisfies $\chi(H) \geq \frac{10}{7}\omega(H)$.*

Proof. Let G be a $(P_5, 4\text{-wheel})$ -free graph. We prove the first assertion by induction on $|V(G)|$. We may assume that G is connected and imperfect. First suppose that G has a clique cut-set, say Q . Let V_1 and V_2 be a partition of $V(G) \setminus Q$ such that V_1 and V_2 are non-empty, and V_1 is anticomplete to V_2 . Then $\chi(G) = \max\{\chi(G[Q \cup V_1]), \chi(G[Q \cup V_2])\} \leq \max\{\frac{3}{2}\omega(G[Q \cup V_1]), \frac{3}{2}\omega(G[Q \cup V_2])\} \leq \frac{3}{2}\omega(G)$, and we are done. So we suppose that G is an atom, and we apply Theorem 3.28. Now if G is a quasi-line graph, then by Theorem G, we have $\chi(G) \leq \frac{3}{2}\omega(G)$. So suppose that G is nice. Then G has three stable sets S_1, S_2 and S_3 such that $\omega(G - (S_1 \cup S_2 \cup S_3)) \leq \omega(G) - 2$. Hence

$\chi(G) \leq \chi(G - (S_1 \cup S_2 \cup S_3)) + 3$ and so by induction hypothesis, $\chi(G) \leq \frac{3}{2}(\omega(G - (S_1 \cup S_2 \cup S_3))) + 3 \leq \frac{3}{2}(\omega(G) - 2) + 3 = \frac{3}{2}\omega(G)$. This proves the first assertion of Theorem 3.29.

To prove the second assertion of Theorem 3.29, we consider the graph $H \cong G^*[K_t]$; see Figure 15 for the graph G^* . Then it is shown in [33] that H is $(3K_1, 4\text{-wheel})$ -free (and hence $(P_5, 4\text{-wheel})$ -free), and that $\omega(H) = 7t$. Moreover, since H has no stable set of size 3, $\chi(H) \geq \frac{|V(H)|}{2} = \frac{20t}{2} = 10t$. This completes the proof of Theorem 3.29. \square

3.6 Concluding remarks

In this chapter, we studied the structure and coloring of the class of $(P_5, 4\text{-wheel})$ -free graphs. In particular, we showed that if G is a $(P_5, 4\text{-wheel})$ -free, then $\chi(G) \leq \frac{3}{2}\omega(G)$. The bound is tight for $\omega = 2$. For instance, if G is a K_2 -free expansion of a C_5 , then G is $(P_5, 4\text{-wheel})$ -free, $\chi(G) = 3$ and $\omega(G) = 2$. Though we do not have a graph G with $\chi(G) = \frac{3}{2}\omega(G)$, where $\omega(G) \geq 3$, the clique expansion of G^* makes us to believe that the bound given in Theorem 3.29 can be improved. So we propose the following:

Conjecture 8 *Every $(P_5, 4\text{-wheel})$ -free graph G satisfies $\chi(G) \leq \lceil \frac{10}{7}\omega(G) \rceil$. Moreover, the bound is tight.*

Also we note that our result generalizes/improves several previously mentioned known results in the literature which are given in Table 4.

Graph Class \mathcal{G}	χ -bound for $G \in \mathcal{G}$	References
$(2P_2, C_4)$ -free graphs	$\omega(G) + 1$	[9, 81, 129]
$(2P_2, K_4 - e)$ -free graphs	$\max\{3, \omega(G)\}$	[74]
$(2P_2, 4\text{-wheel})$ -free graphs	$\omega(G) + 5$	[104]
$(3K_1, C_4)$ -free graphs	$\lceil \frac{5}{4}\omega(G) \rceil$	[34]
$(3K_1, K_4 - e)$ -free graphs	$\max\{3, \omega(G)\}$	[74]
$(3K_1, 4\text{-wheel})$ -free graphs	$2\omega(G)$	[33]
(P_5, C_4) -free graphs	$\lceil \frac{5}{4}\omega(G) \rceil$	[32]
$(P_5, K_4 - e)$ -free graphs	$\max\{3, \omega(G)\}$	[74]

Table 4: Known chromatic bounds for some subclasses of $(P_5, 4\text{-wheel})$ -free graphs.

Chapter 4

Coloring $(P_5, K_5 - e)$ -free graphs

4.1 Introduction

A class of graphs \mathcal{G} is said to be *near optimal colorable* [95] if there is a constant positive integer c such that every graph $G \in \mathcal{G}$ satisfies $\chi(G) \leq \max\{c, \omega(G)\}$. In this chapter¹, we are interested in near optimal colorability for some classes of graphs.

Using Lovász theta function [127], Ju and Huang [95] observed that if \mathcal{G} is a given hereditary class of graphs such that every $G \in \mathcal{G}$ satisfies $\chi(G) \leq \max\{c, \omega(G)\}$ for some constant c , and if k -COLORING for \mathcal{G} is polynomial time solvable for every fixed positive integer $k \leq c - 1$, then CHROMATIC NUMBER for \mathcal{G} can be solved in polynomial time.

For instance, since every $(2P_2, K_1 \vee P_4)$ -free graph satisfies $\chi(G) \leq \max\{3, \omega(G)\}$ [22] and since every (P_6, paw) -free graph satisfies $\chi(G) \leq \max\{4, \omega(G)\}$ [136, 145], clearly the class of $(2P_2, K_1 \vee P_4)$ -free graphs and the class of (P_6, paw) -free graphs are near optimal colorable. Moreover, since k -COLORING can be solved in polynomial time for the class of $2P_2$ -free graphs [86] and 4-COLORING can be solved in polynomial time for P_6 -free graphs [50], hence CHROMATIC NUMBER can be solved in polynomial time for such classes of graphs. Hence the study on near optimal colorability for the class of (H_1, H_2) -free graphs, for various H_1 and H_2 , is of interest.

For any two graphs H_1 and H_2 , Ju and Huang [95] gave a characterization for the near optimal colorability of (H_1, H_2) -free graphs with three exceptional cases. The three exceptional cases are that when H_1 is a forest and $H_2 \in \{K_t, K_t - e, \text{paw}\}$, and we are interested in the following:

Problem 3 ([95]) *Decide whether the class of $(F, K_t - e)$ -free graphs is near optimal colorable when F is a forest and $t \geq 4$.*

Problem 3 seems to be difficult in general even when $F = P_\ell$, $\ell \geq 5$. Recall that every $(P_5, K_4 - e)$ -graph G satisfies $\chi(G) \leq \max\{3, \omega(G)\}$ [74], and that every $(P_6, K_4 - e)$ -graph G satisfies $\chi(G) \leq \max\{6, \omega(G)\}$ [76]. Thus the class of $(P_5, K_4 - e)$ -free graphs and the class of

¹The results of this chapter are appearing in “A. Char and T. Karthick. *On graphs with no induced P_5 or $K_5 - e$* . Submitted for publication. Available on: arXiv:2308.08166[math.CO] (2023).”

$(P_6, K_4 - e)$ -free graphs are near optimal colorable. However, it is unknown that whether the class of $(P_t, K_t - e)$ -free graphs (where $t \geq 5$) is near optimal colorable or not.

Here we focus on the class of $(P_5, K_5 - e)$ -free graphs. This class generalizes the class of (P_5, K_4) -free graphs and the class of $(P_5, K_4 - e)$ -free graphs. Recall that if G is a $(P_5, K_5 - e)$ -free graph with $\omega(G) \leq 3$, then $\chi(G) \leq 5$, and that the bound is tight [63]. Recently, Yian Xu [172] claimed that every $(P_5, K_5 - e)$ -free graph G satisfies $\chi(G) \leq \max\{13, \omega(G) + 1\}$, and the bound is tight when $\omega(G) \geq 12$. However, the proof of the same seems to have some error as it is based on the result which states that if a graph G is $(P_5, C_5, K_5 - e)$ -free and is not a complete graph, then G is 10-colorable (which is obviously not true). For instance, the graph obtained from K_t , $t \geq 11$, by attaching a pendant vertex satisfies all assumptions of the said result, but is not 10-colorable. Moreover, the tight examples given by Xu [172] for $\omega \geq 12$ are clearly not $(K_5 - e)$ -free. Later in 2024, Yian Xu [173] showed that if G is a $(P_5, K_5 - e)$ -free graph containing a C_5 and having no clique cut-set, then $\chi(G) \leq \max\{13, \omega(G)\}$.

Moreover, Malyshev and Lobanova [132] showed the following:

Theorem H ([132]) *Let G be a connected $(P_5, K_5 - e)$ -free graph. If G has no clique cut-set, if $\omega(G) \geq 3 \times 6^7 = 839808$, then G is $3K_1$ -free graph.*

Since every $(3K_1, K_5 - e)$ -free graph H satisfies $\chi(G) \leq \omega(H) + 1$ [108, 111], it follows from Theorem H that if G is a connected $(P_5, K_5 - e)$ -free graph with $\omega(G) \geq 839808$, then either $\chi(G) \leq \omega(G) + 1$ or G has a clique cut-set. In this chapter, we show the following:

- (a) If G is a connected $(P_5, K_5 - e)$ -free graph with $\omega(G) \geq 7$, then either G is the complement of a bipartite graph or G has a clique cut-set. Moreover, there is a connected $(P_5, K_5 - e)$ -free imperfect graph H with $\omega(H) = 6$ and has no clique cut-set. This strengthens Theorem H.
- (b) If G is a $(P_5, K_5 - e)$ -free graph with $\omega(G) \geq 4$, then $\chi(G) \leq \max\{7, \omega(G)\}$. Moreover, the bound is tight when $\omega(G) \notin \{4, 5, 6\}$. This together with a result of Esperet et al. [63] imply that the class of $(P_5, K_5 - e)$ -free graphs is near optimal colorable which partially answers Problem 3, improves a result of Xu [172], and also generalizes/improves the result of [173].

While CHROMATIC NUMBER is known to be NP-hard for the class of P_5 -free graphs, our results together with some known results imply that CHROMATIC NUMBER can be solved in polynomial time for the class of $(P_5, K_5 - e)$ -free graphs.

The above results follow from our structural results for such a class of graphs. Indeed, we study the structure of a $(P_5, K_5 - e)$ -free graph G with $\omega(G) \geq 5$ in detail and prove that either G is the complement of a bipartite graph or G has a clique cut-set or $\chi(G) \leq 7$. Our proof is based on some intermediate results using certain special graphs F_1 , F_2 and F_3 (see Figure 16).

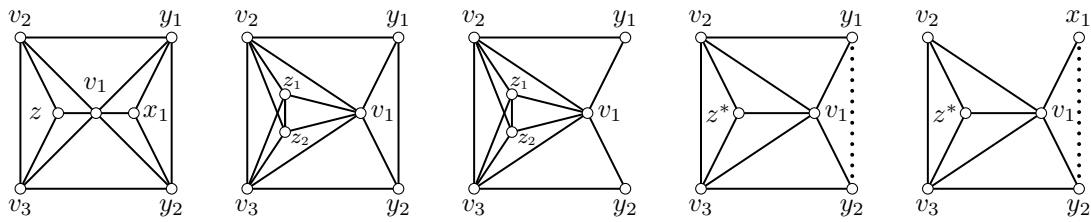

Figure 16: Labeled graphs III: Graphs F_1, F_2, F_3, F_4 and F_5 (left to right). In F_4 and F_5 , the dotted lines between two vertices mean that such vertices may or may not be adjacent.

4.2 Some preliminaries

In this section, we present some terminology and observations used in this chapter. For a positive integer t , let \mathbb{H}_t be the graph obtained from K_{t+3} by adding a new vertex and joining it to exactly two vertices of K_{t+3} . Note that the graph \mathbb{H}_1 is isomorphic to HVN (see Figure 2). We will often use the following simple observations for a $(K_5 - e)$ -free graph G .

Observation 4 *For any two adjacent vertices in G , say u and v , $G[N(u) \cap N(v)]$ is P_3 -free.*

Proof. If there is a P_3 in $G[N(u) \cap N(v)]$ with vertices, say p, q and r , then $\{p, q, r, u, v\}$ induces a $K_5 - e$. So Observation 4 holds. \square

Observation 5 *For any two non-adjacent vertices in G , say u and v , $G[N(u) \cap N(v)]$ is K_3 -free.*

Proof. If there is a K_3 in $G[N(u) \cap N(v)]$ with vertices, say p, q and r , then $\{p, q, r, u, v\}$ induces a $K_5 - e$. So Observation 5 holds. \square

Observation 6 *If there are four mutually disjoint non-empty subsets of $V(G)$ which are complete to each other, then their union is a clique.*

Proof. This follows from Observation 5. \square

We will also use the following theorem to prove our results.

Theorem I ([74]) *Every $(P_5, K_4 - e)$ -free graph G satisfies $\chi(G) \leq \max\{3, \omega(G)\}$.*

From now on, except for the indices of S , we assume that the arithmetic operations on the indices are in integer modulo 3.

4.3 Properties of $(P_5, K_5 - e)$ -free graphs that contain a K_3

To prove the class of $(P_5, K_5 - e)$ -free graphs is near optimal colorable, we begin by proving some simple properties when a $(P_5, K_5 - e)$ -free graph contains a K_3 , and use them in the latter sections.

Let G be a connected $(P_5, K_5 - e)$ -free graph with vertex-set $V(G)$ and edge-set $E(G)$ that contains a K_3 induced by the vertices, say v_1, v_2 and v_3 . Let $C := \{v_1, v_2, v_3\}$. For $i \in \{1, 2, 3\}$, we let:

$$\begin{aligned} X_i &:= \{u \in V(G) \setminus C \mid N(u) \cap C = \{v_i\}\}, \\ Y_i &:= \{u \in V(G) \setminus C \mid N(u) \cap C = C \setminus \{v_i\}\}, \\ Z &:= \{u \in V(G) \setminus C \mid N(u) \cap C = C\}, \text{ and} \\ L &:= \{u \in V(G) \setminus C \mid N(u) \cap C = \emptyset\}. \end{aligned}$$

We let $X := X_1 \cup X_2 \cup X_3$ and $Y := Y_1 \cup Y_2 \cup Y_3$. Then clearly $V(G) = C \cup X \cup Y \cup Z \cup L$. The graphs induced by the subsets defined above have several interesting structural properties which we give in Lemmas 4.1 to 4.3 below.

Lemma 4.1 *The following statements hold:*

- (i) $C \cup Z$ is a clique.
- (ii) $G[Y_i]$ is P_3 -free, and Y is anticomplete to Z .
- (iii) The vertex-set of each component of $G[X_i \cup L]$ is a homogeneous set in $G[X_i \cup X_{i+1} \cup Y_{i+2} \cup L]$.
Likewise, the vertex-set of each component of $G[X_i \cup L]$ is a homogeneous set in $G[X_i \cup X_{i+2} \cup Y_{i+1} \cup L]$.
- (iv) Each vertex in X has at most one neighbor in Z .

Proof. (i): If there are non-adjacent vertices, say z and z' in Z , then $\{v_1, v_2, v_3, z, z'\}$ induces a $K_5 - e$. So Lemma 4.1:(i) holds. ■

(ii): Since Y_i is complete to $\{v_{i+1}, v_{i-1}\}$, $G[Y_i]$ is P_3 -free (by Observation 4). Next, if there are adjacent vertices, say (up to symmetry) $y \in Y_1$ and $z \in Z$, then $\{v_2, v_3, z, y, v_1\}$ induces a $K_5 - e$; so Y is anticomplete to Z . This proves Lemma 4.1:(ii). ■

(iii): We prove the assertion for $i = 1$. Suppose to the contrary that there are vertices, say $p, q \in X_1 \cup L$ and $r \in X_2 \cup Y_3$ such that $pq, pr \in E(G)$ and $qr \notin E(G)$. Then $\{q, p, r, v_2, v_3\}$ induces a P_5 , a contradiction. So Lemma 4.1:(iii) holds. ■

(iv): If there is a vertex in X_i , say x , which has two neighbors in Z , say z and z' , then $zz' \in E(G)$ (by Lemma 4.1:(i)), and then $\{v_i, z, z', v_{i+1}, x\}$ induces a $K_5 - e$. So Lemma 4.1:(iv) holds. □

Lemma 4.2 *Suppose that there is a vertex $t \in L$ which has a neighbor in X_i . Then the following hold:*

- (i) $\{t\}$ is complete to $X_{i+1} \cup X_{i+2}$.
- (ii) X_i is complete to $X_{i+1} \cup X_{i+2}$.

Proof. We prove the lemma for $i = 1$. By our assumption, t has a neighbor in X_1 , say x .

(i): If there is a vertex in X_2 , say p , such that $tp \notin E(G)$, then since $\{t, x, v_1, v_2, p\}$ does not induce a P_5 , we have $xp \in E(G)$, and then $\{t, x, p, v_2, v_3\}$ induces a P_5 ; so $\{t\}$ is complete to X_2 . Likewise, $\{t\}$ is complete to X_3 . This proves Lemma 4.2:(i). ■

(ii): If there are non-adjacent vertices, say $p \in X_1$ and $q \in X_2 \cup X_3$, then $qt, pt \in E(G)$ (by Lemma 4.2:(i)), and then $\{p, t, q, v_2, v_3\}$ induces a P_5 ; so Lemma 4.2:(ii) holds. \square

Lemma 4.3 *The following statements hold:*

- (i) *If $Z \neq \emptyset$, then the vertex-set of any big-component of Y_i is anticomplete $Y_{i+1} \cup Y_{i-1}$.*
- (ii) *Each vertex in L has at most two neighbors in Z .*
- (iii) *For $j \in \{i+1, i-1\}$, if there are vertices, say $p \in X_i \cup Y_j$, $q \in X_j \cup Y_i$, $z \in Z$ and $t \in L$ such that $pt \in E(G)$, then either $pq \in E(G)$ or $qt \in E(G)$. Further if $pz, qz, tz \notin E(G)$, then $pq, qt \in E(G)$.*
- (iv) *Let S be the vertex-set of a component of $G[Y_i]$, and let R be the vertex-set of a component of $G[X_i]$. Suppose that there is a vertex, say $z \in Z$, such that $\{z\}$ is anticomplete to R . Then S is either complete to R or anticomplete to R . Moreover if S is the vertex-set of a big-component of Y_i , and if R is not anticomplete to S , then $G[R]$ is P_3 -free.*
- (v) *Further suppose that G is F_1 -free, and that $Y_{i+1} \cup Y_{i-1} \neq \emptyset$. Then the following hold: If Q is a component of $G[X_i]$, then for any $z \in Z$, $\{z\}$ is either complete to $V(Q)$ or anticomplete to $V(Q)$. Further if there is a vertex, say $z' \in Z$, such that $\{z'\}$ is not anticomplete to $V(Q)$, then Q is P_3 -free.*

Proof. (i): We will show for $i = 1$. Let $z \in Z$. Suppose that the assertion is not true. Then there are vertices, say $p, q \in Y_1$ and $r \in Y_2 \cup Y_3$ such that $pq, pr \in E(G)$. We may assume that $r \in Y_2$. Now since $\{p, q, v_3, v_2, r\}$ does not induce a $K_5 - e$, we have $qr \notin E(G)$, and then $\{q, p, r, v_1, z\}$ induces a P_5 (by Lemma 4.1:(ii)), a contradiction. So Lemma 4.3:(i) holds. \blacksquare

(ii): If there is a vertex in L , say t , which has three neighbors in Z , say z_1, z_2 and z_3 , then since Z is a clique (by Lemma 4.1:(i)), $\{z_1, z_2, z_3, v_1, t\}$ induces a $K_5 - e$. So Lemma 4.3:(ii) holds. \blacksquare

(iii): Suppose not. Then either $\{t, p, v_i, v_j, q\}$ or $\{t, p, q, v_j, z\}$ induces a P_5 . So Lemma 4.3:(iii) holds. \blacksquare

(iv): If there are vertices, say $a, b \in R$ and $c \in S$ such that $ab, ac \in E(G)$ and $bc \notin E(G)$, then $\{b, a, c, v_{i+1}, z\}$ induces a P_5 (by Lemma 4.1:(ii)); so R is a homogeneous set in $G[R \cup S]$. Also, if there are vertices, say $p, q \in S$ and $r \in R$ such that $pq, pr \in E(G)$ and $qr \notin E(G)$, then $\{q, p, r, v_i, z\}$ induces a P_5 (by Lemma 4.1:(ii)); so S is homogeneous set in $G[R \cup S]$. This implies that S is either complete to R or anticomplete to R . This proves the first assertion. The second assertion follows from the first assertion and from Observation 4. This proves Lemma 4.3:(iv). \blacksquare

(v): Let $z \in Z$ and let $y \in Y_{i+1} \cup Y_{i-1}$. Suppose to the contrary that there are vertices, say $x, x' \in V(Q)$ such that $xx', xz \in E(G)$ and $x'z \notin E(G)$. We may assume that $y \in Y_{i+1}$. Then since $\{x', x, z, v_{i+2}, y\}$ does not induce a P_5 , we have $xy, x'y \in E(G)$ (by Lemma 4.1:(iii)), and then $\{x, z, v_3, y, v_1, x', v_2\}$ induces an F_1 , a contradiction. This proves the first assertion.

Since $V(Q)$ is complete to $\{v_i\}$, the second assertion follows from the first assertion and from Observation 4. This proves Lemma 4.3:(v). \square

Next we prove the following crucial and useful theorem.

Theorem 4.4 *Let G be a connected $(P_5, K_5 - e)$ -free graph with $\omega(G) \geq t + 3$ where $t \geq 1$. If G is \mathbb{H}_t -free, then either G is the complement of a bipartite graph or G has a clique cut-set.*

Proof. Let G be a connected $(P_5, K_5 - e)$ -free graph which has no clique cut-set. We show that G is the complement of a bipartite graph. We may assume that G is not a complete graph. Since $\omega(G) \geq t + 3$, there are vertices, say $v_1, v_2, v_3, \dots, v_{t+3}$ in $V(G)$ such that $\{v_1, v_2, v_3, \dots, v_{t+3}\}$ induces a K_{t+3} , say K . Let $C := \{v_1, v_2, v_3\}$. Then, with respect to C , we define the sets X, Y, Z and L as above, and we use Lemmas 4.1 and 4.2. Note that $\{v_4, \dots, v_{t+3}\} \subseteq Z$. Since $t \geq 1$, $Z \neq \emptyset$. Moreover the following hold.

- (a) For any $y \in Y$, since $K \cup \{y\}$ does not induce an \mathbb{H}_t (by Lemma 4.1:(ii)), we have $Y = \emptyset$.
- (b) If there are adjacent vertices, say $x \in X$ and $z \in Z$, then $\{x\}$ is anticomplete to $Z \setminus \{z\}$ (by Lemma 4.1:(iv)), and then $K \cup \{x\}$ induces an \mathbb{H}_t ; so X is anticomplete to Z .
- (c) By (a) and (b), since C is not a clique cut-set separating Z and X , we have $L \neq \emptyset$.
- (d) For each $i \in \{1, 2, 3\}$, since $Z \cup \{v_{i+1}, v_{i-1}\}$ is not a clique cut-set separating $\{v_i\}$ and L (by Lemma 4.1:(i) and (c)), we have $X_i \neq \emptyset$, for each $i \in \{1, 2, 3\}$.
- (e) Since G is connected, and since Z is not a clique cut-set separating $\{v_1\}$ and the vertex-set of a component of $G[L]$ (by Lemma 4.1:(i) and (c)), the vertex-set of each component of $G[L]$ is not anticomplete to X . So X is complete to L , and X_i is complete to X_{i+1} , for each $i \in \{1, 2, 3\}$ (by Lemma 4.1:(iii) and Lemma 4.2).

Now from (c), (d) and (e), since $G[X_1 \cup X_2 \cup X_3 \cup L]$ does not contain a $K_5 - e$, it follows from Observation 6 that $X \cup L$ is a clique. Also $C \cup Z$ is a clique (by Lemma 4.1:(i)). Thus from (a), we conclude that G is the complement of a bipartite graph. This proves Theorem 4.4. \square

4.4 $(P_5, K_5 - e)$ -free graphs that contain some special graphs

4.4.1 $(P_5, K_5 - e)$ -free graphs that contain an F_1

Let G be a connected $(P_5, K_5 - e)$ -free graph which has no clique cut-set. Suppose that G contains an F_1 with vertices and edges as shown in Figure 16. Let $C := \{v_1, v_2, v_3\}$. Then, with respect to C , we define the sets X, Y, L and Z as in Section 4.3, and we use the lemmas in Section 4.3. Clearly $x_1 \in X_1, y_2 \in Y_2, y_3 \in Y_3$ and $z \in Z$ so that X_1, Y_2, Y_3 and Z are non-empty. Recall that $C \cup Z$ is a clique (by Lemma 4.1:(i)), and that Y is anticomplete to Z (by Lemma 4.1:(ii)). Moreover the graph G has some more properties which we give in Lemmas 4.5 to 4.7 below.

Lemma 4.5 *The following hold:*

- (i) $Y_2 = \{y_2\}$. Likewise, $Y_3 = \{y_3\}$.
- (ii) Y_1 is anticomplete to $\{x_1\} \cup Y_2 \cup Y_3$.
- (iii) L is anticomplete to $\{x_1\} \cup X_2 \cup X_3$.

(iv) Every vertex in $X_2 \cup X_3$ has a neighbor in $\{y_2, y_3\}$.

(v) For $j \in \{2, 3\}$, $\{z\}$ is either complete to X_j or anticomplete to X_j .

Proof. (i): Suppose to the contrary that there is a vertex in $Y_2 \setminus \{y_2\}$, say p . By Lemma 4.3:(i), $py_2 \notin E(G)$. Then since $\{x_1, y_3, v_2, v_3, p\}$ or $\{x_1, y_3, p, v_3, z\}$ does not induce a P_5 (by Lemma 4.1:(ii)), $px_1 \in E(G)$ and $py_3 \in E(G)$. Then $\{x_1, y_3, v_1, p, y_2\}$ induces a $K_5 - e$, a contradiction. So Lemma 4.5:(i) holds. ■

(ii): Suppose to the contrary that there is a vertex in Y_1 , say p , which has a neighbor in $\{x_1, y_2, y_3\}$ (by Lemma 4.5:(i)). Since $\{v_1, x_1, y_2, y_3, p\}$ does not induce a $K_5 - e$, p has a non-neighbor in $\{x_1, y_2, y_3\}$. Now if $px_1 \in E(G)$, then we may assume (up to symmetry) that $py_2 \notin E(G)$, and then $\{y_2, x_1, p, v_2, z\}$ induces a P_5 , a contradiction; so $px_1 \notin E(G)$. Then we may assume (up to symmetry) that $py_2 \in E(G)$, and then $\{x_1, y_2, p, v_2, z\}$ induces a P_5 , a contradiction. So Lemma 4.5:(ii) holds. ■

(iii): If there is a vertex, say $t \in L$, such that $tx_1 \in E(G)$, then $\{x_1, y_2, y_3, t, v_1\}$ induces a $K_5 - e$ (by Lemma 4.1:(iii)); so L is anticomplete to $\{x_1\}$. This implies that L is anticomplete to $X_2 \cup X_3$ (by Lemma 4.2:(i)). This proves Lemma 4.5:(iii). ■

(iv): Suppose to the contrary that there is a vertex in $X_2 \cup X_3$, say p , which is anticomplete to $\{y_2, y_3\}$. We may assume, up to symmetry, that $p \in X_2$. Now since $\{x_1, y_2, v_3, v_2, p\}$ does not induce a P_5 , $px_1 \in E(G)$, and then one of $\{y_3, x_1, p, z, v_3\}$ or $\{p, x_1, y_2, v_3, z\}$ induces a P_5 , a contradiction. So Lemma 4.5:(iv) holds. ■

(v): We prove the assertion for $j = 2$. Suppose to the contrary that there are vertices, say $p, q \in X_2$ such that $pz \in E(G)$ and $qz \notin E(G)$. Since one of $\{x_1, y_2, v_3, v_2, q\}$ or $\{y_2, x_1, q, v_2, z\}$ does not induce a P_5 , $qx_1, qy_2 \in E(G)$. Then since $\{v_1, x_1, y_2, y_3, q\}$ does not induce a $K_5 - e$, $qy_3 \notin E(G)$. Then since $\{q, x_1, v_1, z, p\}$ does not induce a P_5 , either $pq \in E(G)$ or $px_1 \in E(G)$. Now if $pq \in E(G)$, then $py_3 \notin E(G)$ and $px_1 \in E(G)$ (by Lemma 4.1:(iii)), and then $\{y_3, x_1, p, z, v_3\}$ induces a P_5 , a contradiction. So, we may assume that $pq \notin E(G)$, and hence $px_1 \in E(G)$. Then $\{q, x_1, p, z, v_3\}$ induces a P_5 , a contradiction. So Lemma 4.5:(v) holds. □

Lemma 4.6 *The set $X_1 \cup Y_2 \cup Y_3$ is a clique.*

Proof. By Lemma 4.1:(iii) and Lemma 4.5:(i), it is enough to show that X_1 is a clique. Suppose to the contrary that there are non-adjacent vertices in X_1 , say p and q . Since $\{y_2, y_3, x_1, p, q\}$ does not induce a $K_5 - e$ (by Lemma 4.1:(iii)), we may assume that $px_1 \notin E(G)$, and hence $X_1 \setminus (N(x_1) \cup \{x_1\}) \neq \emptyset$. We let $X'_1 := X_1 \setminus (N(x_1) \cup \{x_1\})$ and let $L' := \{t \in L \mid t \text{ has a neighbor in } X'_1\}$. Moreover, we have the following.

4.6.1 X'_1 is anticomplete to $\{z\}$.

Proof of 4.6.1. Since for any $x \in X'_1$, one of $\{x, z, v_3, y_2, x_1\}$, $\{x_1, y_2, x, z, v_2\}$ does not induce a P_5 , we have X'_1 is anticomplete to $\{z\}$. This proves 4.6.1. ■

4.6.2 X'_1 is anticomplete to $Y \cup Z$.

Proof of 4.6.2. Let $x \in X'_1$ be arbitrary. If $xy_2 \in E(G)$, then $\{y_2, y_3, v_1, x, x_1\}$ induces a $K_5 - e$ or $\{x, y_2, y_3, v_2, z\}$ induces a P_5 (by 4.6.1); so $xy_2 \notin E(G)$. Likewise, $xy_3 \notin E(G)$. Hence for any $w \in Y_1 \cup Z$, since $\{x, w, v_2, y_3, y_2\}$ does not induce a P_5 (by Lemma 4.5:(ii)), $\{x\}$ is anticomplete to $Y_1 \cup Z$. So $\{x\}$ is anticomplete to $Y \cup Z$ (by Lemma 4.5:(i)). This proves 4.6.2. ■

4.6.3 X'_1 is anticomplete to $X_2 \cup X_3$.

Proof of 4.6.3. Suppose not. Then there are adjacent vertices, say $x \in X'_1$ and $a \in X_2 \cup X_3$. Suppose $a \in X_2$. Since $\{x, a, v_2, v_3, y_2\}$ does not induce a P_5 , $ay_2 \in E(G)$. If $az \notin E(G)$, then $\{x, a, y_2, v_3, z\}$ induces a P_5 (by 4.6.2); so we may assume that $az \in E(G)$. Now since $\{v_1, x_1, y_2, y_3, a\}$ does not induce a $K_5 - e$ or $\{x_1, y_3, a, z, v_3\}$ does not induce a P_5 , we have $x_1a, ay_3 \notin E(G)$, and then $\{x, a, v_2, y_3, x_1\}$ induces a P_5 ; so $\{x\}$ is anticomplete to X_2 . Likewise, $\{x\}$ is anticomplete to X_3 . So X'_1 is anticomplete to $X_2 \cup X_3$. This proves 4.6.3. ■

4.6.4 X'_1 is anticomplete to $(X_1 \setminus X'_1) \cup (L \setminus L')$ and L' is anticomplete to $L \setminus L'$.

Proof of 4.6.4. Since $y_2x_1 \in E(G)$, it follows from Lemma 4.1:(iii) that $\{y_2\}$ is complete to $X_1 \setminus X'_1$. So it follows from 4.6.2 and Lemma 4.1:(iii) that X'_1 is anticomplete to $X_1 \setminus X'_1$. Further $X'_1 \cup L'$ is anticomplete to $L \setminus L'$ (by the definition of L' and by Lemma 4.1:(iii)). This proves 4.6.4. ■

4.6.5 L' is anticomplete to $(X_1 \setminus X'_1) \cup Y \cup Z$.

Proof of 4.6.5. By 4.6.2 and Lemma 4.1:(iii), L' is anticomplete to $Y_2 \cup Y_3$. So L' is anticomplete to $(X_1 \cap N(x_1)) \cup \{x_1\}$ (by Lemma 4.1:(iii)). Hence $X_2 \cup X_3 = \emptyset$ (by Lemma 4.2:(i)). If $t \in L'$ has a neighbor in $Y_1 \cup Z$, say w , then for any neighbor of t in X'_1 , say a' , we see that $\{a', t, w, v_3, y_2\}$ induces a P_5 (by Lemma 4.5:(ii)); so L' is anticomplete to $Y_1 \cup Z$. This proves 4.6.5. ■

Recall that $V(G) \setminus (X'_1 \cup L' \cup \{v_1\}) = \{v_2, v_3\} \cup (X \setminus X'_1) \cup Y \cup Z \cup (L \setminus L')$. So by above claims, $X'_1 \cup L'$ is anticomplete to $V(G) \setminus (X'_1 \cup L' \cup \{v_1\})$, and thus v_1 is a cut-vertex in G , a contradiction. This proves Lemma 4.6. □

Lemma 4.7 *The set L is an empty set.*

Proof. Suppose to the contrary that $L \neq \emptyset$. First we assume that $N(y_2) \cap L = \emptyset$ and $N(y_3) \cap L = \emptyset$. Then L is anticomplete to X (by Lemma 4.5:(iii), Lemma 4.6, and by Lemma 4.1:(iii)). Since Z is a clique (by Lemma 4.1:(i)) and since Z is not a clique cut-set of G separating L and C (by Lemma 4.5:(i)), L is not anticomplete to Y_1 , and so there are adjacent vertices, say $y \in Y_1$ and $t \in L$. Then $\{y_2, y_3, v_2, y, t\}$ induces a P_5 (by Lemma 4.5:(ii)), a contradiction. So we may assume, up to symmetry, that $N(y_2) \cap L \neq \emptyset$, and let $t \in N(y_2) \cap L$. Then $tx_1 \notin E(G)$ (by Lemma 4.5:(iii)). Next we claim the following.

4.7.1 $\{z\}$ is anticomplete to L .

Proof of 4.7.1. Suppose to the contrary that z has a neighbor in L , say p . Then since $\{x_1, y_2, p, z, v_2\}$ does not induce a P_5 (by Lemma 4.5:(iii)), $p \neq t$ and $y_2p \notin E(G)$. So $tp \notin E(G)$ (by Lemma 4.1:(iii)), and then $\{t, y_2, v_1, z, p\}$ induces a P_5 , a contradiction. So $\{z\}$ is anticomplete to L . This proves 4.7.1. ■

4.7.2 $\{z\}$ is anticomplete to X .

Proof of 4.7.2. Suppose to the contrary that z has a neighbor in X , say x . If $x \in X_1$, then $\{t, y_2, x, z, v_2\}$ induces a P_5 , a contradiction. If $x \in X_2$, then since $\{t, y_2, y_3, v_2, z\}$ does not induce a P_5 , we have $ty_3 \in E(G)$, and then either $\{t, y_3, v_1, z, x\}$ or $\{t, y_3, x, z, v_3\}$ induces a P_5 (by Lemma 4.5:(iii)), a contradiction. We get a similar contradiction when $x \in X_3$. These contradictions show that $\{z\}$ is anticomplete to X . This proves 4.7.2. ■

Thus by Lemma 4.1:(ii) and by above claims, $C \cup (Z \setminus \{z\})$ is a clique cut-set of G separating $\{z\}$ and the rest of the vertices, a contradiction. This proves Lemma 4.7. □

Now we prove the main theorem of this subsection, and is given below.

Theorem 4.8 *Let G be a connected $(P_5, K_5 - e)$ -free graph. If G contains an F_1 , then either G is the complement of a bipartite graph or G has a clique cut-set or $\chi(G) \leq 5$.*

Proof. Let G be a connected $(P_5, K_5 - e)$ -free graph. Suppose that G contains an F_1 with vertices and edges as shown in Figure 16. Let $C := \{v_1, v_2, v_3\}$. Then, with respect to C , we define the sets X, Y, L and Z as in Section 4.3, and we use the lemmas in Section 4.3. Clearly $x_1 \in X_1, y_2 \in Y_2, y_3 \in Y_3$ and $z \in Z$ so that X_1, Y_2, Y_3 and Z are non-empty. We may assume that G has no clique cut-set, and that G is not the complement of a bipartite graph. We also use Lemmas 4.5 to 4.7. By Lemma 4.7, $L = \emptyset$. Recall that $C \cup Z$ is a clique (by Lemma 4.1:(i)), and that Y is anticomplete to Z (by Lemma 4.1:(ii)). We show that $\chi(G) \leq 5$ using a sequence of claims given below.

4.8.1 $X_1 = \{x_1\}$.

Proof of 4.8.1. Suppose not, and let $X_1 \setminus \{x_1\} \neq \emptyset$, say $x'_1 \in X_1 \setminus \{x_1\}$. By Lemma 4.6, $X_1 \cup Y_2 \cup Y_3$ is a clique. For any $x \in X_2 \cup X_3$, since $G[\{v_1, x_1, x'_1, y_2, y_3, x\}]$ does not contain a $K_5 - e$ (by Lemma 4.5:(iv) and Lemma 4.1:(iii)), we see that $X_2 \cup X_3$ is anticomplete to X_1 . Also, since $(X_1 \setminus \{x_1\}) \cup Y_2 \cup Y_3 \cup \{v_1\}$ is not a clique cut-set of G (by Lemma 4.5:(ii)) separating $\{x_1\}$ and Z , there is a vertex in Z , say z' , such that $x_1z' \in E(G)$. Now, we have the following:

- (a) For any $p \in X_1 \setminus \{x_1\}$, since $\{x_1, p, v_1, z', y_2\}$ does not induce a $K_5 - e$ (by Lemma 4.1:(ii)), we have $X_1 \setminus \{x_1\}$ is anticomplete to $\{z'\}$. In particular, $x'_1z' \notin E(G)$.
- (b) Next, we claim that $X_2 \cup X_3 = \emptyset$. Suppose not, and let $q \in X_2$. Then since $\{x'_1, x_1, z', v_2, q\}$ does not induce a P_5 (by (a)), $qz' \in E(G)$. Then $qz \notin E(G)$ (by Lemma 4.1:(iv)). But then one of $\{v_3, z', q, y_3, x'_1\}$ or $\{x_1, y_2, q, v_2, z\}$ induces a P_5 (by Lemma 4.5:(iv) and (a)), a contradiction. So $X_2 = \emptyset$. Likewise, $X_3 = \emptyset$.

- (c) Finally, we claim that $Y_1 = \emptyset$. Suppose not. Then since $\{v_2, v_3\}$ is not a clique cut-set of Y_1 and the rest of the vertices (by (b) and Lemma 4.5:(ii)), $X_1 \setminus \{x_1\}$ is not anticomplete to Y_1 . So there are adjacent vertices, say $p \in X_1 \setminus \{x_1\}$ and $q \in Y_1$. Then $\{y_2, p, q, v_2, z'\}$ induces a P_5 (by Lemma 4.1:(ii) and (a)), a contradiction. So $Y_1 = \emptyset$.

Then, by above arguments, $V(G)$ can be partitioned into two cliques, namely, $X_1 \cup Y_2 \cup Y_3$ and $C \cup Z$. Thus G is the complement of a bipartite graph, a contradiction. So $X_1 = \{x_1\}$. This proves 4.8.1. ■

4.8.2 $X \cup Y = \{x_1, y_2, y_3\} \cup X_2 \cup X_3$.

Proof of 4.8.2. By 4.8.1 and Lemma 4.5:(i), it is enough to show that $Y_1 = \emptyset$. First we show that $X_2 \cup X_3$ is anticomplete to Y_1 . Suppose to the contrary that there are adjacent vertices, say $p \in X_2 \cup X_3$ and $q \in Y_1$. We may assume, up to symmetry, that $p \in X_2$. From Lemma 4.1:(ii) and Lemma 4.5:(ii), $\{q\}$ is anticomplete to $\{z, x_1, y_2, y_3\}$. Then since $\{y_3, v_1, v_3, q, p\}$ and $\{x_1, v_1, v_3, q, p\}$ do not induce P_5 's, we have $py_3, px_1 \in E(G)$. Then since $\{y_3, p, q, v_3, z\}$ does not induce a P_5 , we have $pz \in E(G)$, and since $\{v_1, x_1, y_2, y_3, p\}$ does not induce a $K_5 - e$, we have $py_2 \notin E(G)$. Now $\{q, p, z, v_1, y_2\}$ induces a P_5 , a contradiction. So $X_2 \cup X_3$ is anticomplete to Y_1 . Hence from Lemma 4.1:(ii), 4.8.1 and Lemma 4.5:(ii), we conclude that Y_1 is anticomplete to $X \cup Y_2 \cup Y_3 \cup Z \cup L$. Now since $\{v_2, v_3\}$ is not a clique cut-set of G separating Y_1 and the rest of the vertices in G , we have $Y_1 = \emptyset$. This proves 4.8.2. ■

4.8.3 $|Z \setminus \{z\}| \leq 1$.

Proof of 4.8.3. Suppose not. Then there is a vertex in $Z \setminus \{z\}$, say z' , such that $x_1z' \notin E(G)$ (by Lemma 4.1:(iv)). By 4.8.2, since $C \cup (Z \setminus \{z'\})$ is not a clique cut-set of G separating $\{z'\}$ and the rest of the vertices, we may assume that z' has a neighbor in X_2 , say q . Then $qz \notin E(G)$ (by Lemma 4.1:(iv)). Then as in the proof of Lemma 4.5:(v), we have $qx_1, qq_2 \in E(G)$, and $qq_3 \notin E(G)$. Then $\{y_3, x_1, q, z', v_3\}$ induces a P_5 (by Lemma 4.1:(ii)), a contradiction. So 4.8.3 holds. ■

4.8.4 For $j \in \{2, 3\}$, $G[X_j]$ is the union of K_2 's and K_1 's.

Proof of 4.8.4. We prove the claim for $j = 2$. Let Q be a component of $G[X_2]$. It is enough to show that $V(Q)$ induces a (P_3, K_3) -free graph. By Lemma 4.5:(v), we have either $V(Q)$ is complete to $\{z\}$ or $V(Q)$ is anticomplete to $\{z\}$. First suppose that $V(Q)$ is complete to $\{z\}$. Then since $V(Q)$ is complete to $\{v_2, z\}$, by Observation 4, Q is P_3 -free. Also, since $G[\{z, y_2, y_3\} \cup V(Q)]$ does not contain a $K_5 - e$ (by Lemma 4.1:(iii) and Lemma 4.5:(iv)), Q is K_3 -free, and we are done. So we may assume that $V(Q)$ is anticomplete to $\{z\}$. Then as in the proof of Lemma 4.5:(v), we see that $V(Q)$ is complete to $\{x_1, y_2\}$, by using Lemma 4.1:(iii). Thus Q is P_3 -free (by Observation 4), and since $G[\{x_1, v_2\} \cup V(Q)]$ does not contain a $K_5 - e$, Q is K_3 -free. This proves 4.8.4. ■

By 4.8.4, for $j \in \{2, 3\}$, we let $X_j := A_j \cup B_j$, where A_j and B_j are stable sets such that B_j is maximal. Then we have the following:

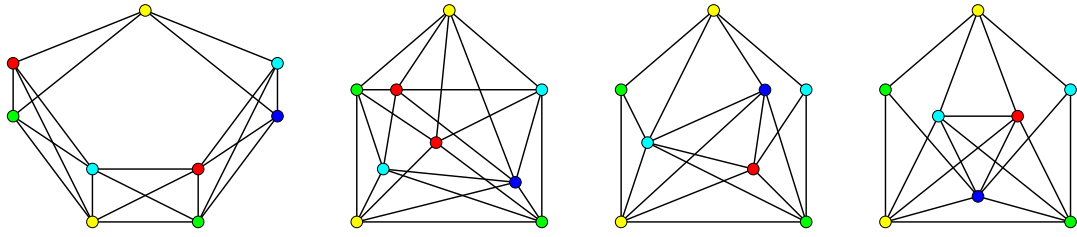

Figure 17: The graphs G_1, G_2, G_3 and G_4 (left to right).

4.8.5 $A_2 \cup \{y_3\}$ is a stable set. Likewise, $A_3 \cup \{y_2\}$ is a stable set.

Proof of 4.8.5. Suppose to the contrary that there is a vertex in A_2 , say p , such that $py_3 \in E(G)$. Then by our definition of A_2 , since B_2 is a maximal stable set, there is a vertex in B_2 , say q , such that $pq \in E(G)$. Since $\{p, q, v_2, y_3, z\}$ does not induce a $K_5 - e$ (by Lemma 4.1:(iii)), we have $pz \notin E(G)$ (by Lemma 4.5:(v)). Then since $\{p, y_3, y_2, v_3, z\}$ does not induce a P_5 , we have $py_2 \in E(G)$, and then since $\{v_1, x_1, y_2, y_3, p\}$ does not induce a $K_5 - e$, we have $px_1 \notin E(G)$. But then $\{x_1, y_2, p, v_2, z\}$ induces a P_5 , a contradiction. So 4.8.5 holds. ■

By 4.8.2, we conclude that $V(G) = C \cup Z \cup A_2 \cup B_2 \cup A_3 \cup B_3 \cup \{x_1, y_2, y_3\}$. Since $C \cup (Z \setminus \{z\})$ is not a clique cut-set of G separating $\{z\}$ and the rest of the vertices in G , z has a neighbor in $X_2 \cup X_3$. So we may assume that $\{z\}$ is complete to X_2 (by Lemma 4.5:(v)), and hence X_2 is anticomplete to $Z \setminus \{z\}$ (by Lemma 4.1:(iv)). Also $Z \setminus \{z\}$ is anticomplete to $\{y_3\}$ (by Lemma 4.1:(ii)). Now by using 4.8.3 and 4.8.5, we define the following stable sets: $S_1 := A_2 \cup (Z \setminus \{z\}) \cup \{y_3\}$, $S_2 := B_2 \cup \{v_3\}$, $S_3 := \{x_1, z\}$, $S_4 := A_3 \cup \{y_2, v_2\}$ and $S_5 := B_3 \cup \{v_1\}$. Clearly $V(G) = \bigcup_{j=1}^5 S_j$, and hence $\chi(G) \leq 5$. This proves Theorem 4.8. □

4.4.2 $(P_5, K_5 - e, F_1)$ -free graphs that contain an F_2

Let G be a connected $(P_5, K_5 - e, F_1)$ -free graph which has no clique cut-set. Suppose that G contains an F_2 with vertices and edges as shown in Figure 16. Let $C := \{v_1, v_2, v_3\}$. Then with respect to C , we define the sets X, Y, Z and L as in Section 4.3, and we use the lemmas in Section 4.3. Clearly $y_2 \in Y_2, y_3 \in Y_3$ and $z_1, z_2 \in Z$ so that Y_2, Y_3 and Z are non-empty. Recall that $C \cup Z$ is a clique (by Lemma 4.1:(i)), and that Y is anticomplete to Z (by Lemma 4.1:(ii)). Moreover, the graph G has some more properties which we give below in Lemmas 4.9 to 4.11.

Lemma 4.9 *The following hold:*

- (i) X_1 is anticomplete to $Y_2 \cup Y_3$. Likewise, if $Y_1 \neq \emptyset$, then for each $i \in \{1, 2, 3\}$, X_i is anticomplete to $Y_{i+1} \cup Y_{i-1}$.
- (ii) X_1 is anticomplete to Z .
- (iii) If a vertex in X has a neighbor in Z , then it is adjacent to both y_2 and y_3 .
- (iv) X_1 is anticomplete to $X_2 \cup X_3$. Likewise, if $Y_1 \neq \emptyset$, then for each $i \in \{1, 2, 3\}$, X_i is anticomplete to $X_{i+1} \cup X_{i-1}$.

(v) For $j \in \{2, 3\}$, $|z \in Z : N(z) \cap X_j \neq \emptyset| \leq 1$.

Proof. (i): Suppose to the contrary that there are adjacent vertices, say $x \in X_1$ and $y \in Y_2 \cup Y_3$. We may assume (up to symmetry) that $y \in Y_2$, and we may assume that $xz_1 \notin E(G)$ (by Lemma 4.1:(iv)). Then since one of $\{x, y, v_3, v_2, y_3\}$ or $\{x, y, y_3, v_2, z_1\}$ does not induce a P_5 , we have $xy_3, yy_3 \in E(G)$, and then $\{v_1, v_2, v_3, x, y, y_3, z_1\}$ induces an F_1 , a contradiction. So Lemma 4.9:(i) holds. ■

(ii): If there are adjacent vertices, say $x \in X_1$ and $z \in Z$, then $\{x, z, v_3, y_2, y_3\}$ induces a P_5 (by Lemma 4.1:(ii) and Lemma 4.9:(i)). So Lemma 4.9:(ii) holds. ■

(iii): Let x be a vertex in X which has a neighbor in Z , say z . We may assume that $z \neq z_1$ (by Lemma 4.1:(iv)). Clearly $x \notin X_1$ (by Lemma 4.9:(ii)), and we may assume, up to symmetry, that $x \in X_2$. Then $xz_1 \notin E(G)$ (by Lemma 4.1:(iv)). Then since one of $\{x, z, v_3, y_2, y_3\}$ or $\{y_2, y_3, x, z, z_1\}$ does not induce a P_5 (by Lemma 4.1:(i)), we have $xy_2, xy_3 \in E(G)$. This proves Lemma 4.9:(iii). ■

(iv): Suppose to the contrary that there are adjacent vertices, say $x \in X_1$ and $x' \in X_2 \cup X_3$. We may assume (up to symmetry) that $x' \in X_2$. Also we may assume that $x'z_1 \notin E(G)$ (by Lemma 4.1:(iv)). Moreover, $xz_1, xy_2, xy_3 \notin E(G)$ (by Lemma 4.9:(i) and Lemma 4.9:(ii)). Then one of $\{x, x', v_2, v_3, y_2\}$ or $\{x, x', y_2, v_3, z_1\}$ induces a P_5 , a contradiction. So Lemma 4.9:(iv) holds. ■

(v): We will show for $j = 2$. Suppose that the assertion is not true. Then there are vertices, say x, x' in X_2 , and z, z' in Z such that $xz, x'z' \in E(G)$. Then $xz', x'z \notin E(G)$ (by Lemma 4.1:(iv)), and $xy_3, x'y_3 \in E(G)$ (by Lemma 4.9:(iii)). Now since $\{x, y_3, x', z', v_3\}$ does not induce a P_5 , we have $xx' \in E(G)$. But then $\{z, z', v_2, v_3, x, x', y_3\}$ induces an F_1 , a contradiction. So Lemma 4.9:(v) holds. □

Lemma 4.10 For $i \in \{1, 2, 3\}$, suppose that there are vertices, say $p \in X_i, y \in Y_i, z \in Z$ and $t \in L$ such that $pt, zt \in E(G)$ and $pz \notin E(G)$. Then for $j \in \{i+1, i-1\}$, the following hold:

(i) $\{p, t\}$ is complete to Y_j .

(ii) If y has a neighbor in Y_j , then $\{y\}$ is complete to $Y_j \cup \{p\}$.

Proof. We will show for $j = i+1$.

(i): Since for any $y' \in Y_{i+1}$, $\{p, t, z, v_{i-1}, y'\}$ does not induce a P_5 , $\{p, t\}$ is complete to Y_{i+1} (by Lemma 4.1:(iii)). This proves Lemma 4.10:(i). ■

(ii): To prove Lemma 4.10:(ii), we pick neighbor of y in Y_{i+1} , say r . Then since $\{p, r, y, v_{i+1}, z\}$ does not induce a P_5 , $py \in E(G)$. Hence, for any $u \in Y_{i+1}$, $\{u, p, y, v_{i+1}, z\}$ does not induce a P_5 , $\{y\}$ is complete to Y_{i+1} . This proves Lemma 4.10. □

Lemma 4.11 For any $t \in L$, we have either $ty_2 \in E(G)$ or $ty_3 \in E(G)$.

Proof. Suppose not. Let $t \in L$ be such that $ty_2, ty_3 \notin E(G)$. Let Q be the component of $G[L]$ such that $t \in V(Q)$. Then $V(Q)$ is anticomplete to $\{y_2, y_3\}$ (by Lemma 4.1:(iii)). We claim that

$V(Q)$ is anticomplete to $X_2 \cup X_3 \cup Y \cup Z$. If not, then there are adjacent vertices, say $a \in V(Q)$ and (up to symmetry) $b \in Z \cup X_2 \cup Y_1$. If $b \in Z$, then $\{a, b, v_3, y_2, y_3\}$ induces a P_5 ; so $V(Q)$ is anticomplete to Z . If $b \in X_2 \cup Y_1$, then we may assume that $bz_1 \notin E(G)$ (by Lemma 4.1:(ii) and Lemma 4.1:(iv)), and then $\{a, b, v_2, v_1, y_2\}$ or $\{a, b, y_2, v_1, z_1\}$ induces a P_5 ; so $V(Q)$ is anticomplete to $X_2 \cup X_3 \cup Y \cup Z$. Now since G is connected, $V(Q)$ is not anticomplete to X_1 , and so there are adjacent vertices, say $q \in V(Q)$ and $x \in X_1$. Then by Lemma 4.2:(i) and Lemma 4.9:(iv), $X_2 \cup X_3 = \emptyset$. Since X_1 is anticomplete to $Y_2 \cup Y_3 \cup Z$ (by Lemma 4.9:(i) and Lemma 4.9:(ii)), and since $C \cup Z$ is not a clique cut-set of G (by Lemma 4.1:(i) and Lemma 4.1:(iii)) separating $X_1 \cup V(Q)$ and $Y_2 \cup Y_3$, X_1 is not anticomplete to Y_1 . So $Y_1 \neq \emptyset$, and let $y \in Y_1$. But then one of $\{q, x, v_1, v_2, y\}$ or $\{q, x, y, v_2, z_1\}$ induces a P_5 (by Lemma 4.1:(ii) and Lemma 4.9:(ii)), a contradiction. So Lemma 4.11 holds. \square

Now we prove the main theorem of this subsection, and is given below.

Theorem 4.12 *Let G be a connected $(P_5, K_5 - e)$ -free graph. If G contains an F_2 , then either G is the complement of a bipartite graph or G has a clique cut-set or $\chi(G) \leq 5$.*

Proof. Let G be a connected $(P_5, K_5 - e)$ -free graph. Suppose that G contains an F_2 with vertices and edges as shown in Figure 16. Let $C := \{v_1, v_2, v_3\}$. Then, with respect to C , we define the sets X, Y, Z and L as in Section 4.3, and use the lemmas in Section 4.3. Clearly, $y_2 \in Y_2, y_3 \in Y_3$ and $z_1, z_2 \in Z$, so that Y_2, Y_3 and Z are non-empty. Recall that $C \cup Z$ is a clique (by Lemma 4.1:(i)), and that Y is anticomplete to Z (by Lemma 4.1:(ii)). We may assume that G has no clique cut-set, and that G is not the complement of a bipartite graph. From Theorem 4.8, we may assume that G is F_1 -free, and we use Lemma 4.9 and Lemma 4.11. We show that $\chi(G) \leq 5$ by using a sequence of claims given below.

4.12.1 X_1 is anticomplete to L .

Proof of 4.12.1. This follows from Lemma 4.1:(iii), Lemma 4.9:(i) and Lemma 4.11. \blacksquare

4.12.2 L is complete to Z , and so L induces a bipartite graph.

Proof of 4.12.2. Suppose to the contrary that there are non-adjacent vertices, say $t \in L$ and $z \in Z$. Let Q be the component of $G[L]$ such that $t \in V(Q)$. We may assume that $ty_2 \in E(G)$ (by Lemma 4.11). Then since $\{t, y_2, y_3, v_2, z\}$ does not induce a P_5 (by Lemma 4.1:(ii)), we have $ty_3 \in E(G)$. So $V(Q)$ is complete to $\{y_2, y_3\}$ (by Lemma 4.1:(iii)), and hence $V(Q)$ is a clique (by Observation 4). Moreover, we have the following:

- (a) Since for any $y \in Y_3$, one of $\{t, y_2, y, v_2, z\}$ or $\{y, v_2, v_3, y_2, t\}$ does not induce a P_5 , Y_3 is complete to $\{t, y_2\}$. By using similar arguments, we see that Y_2 is complete to $Y_3 \cup \{t\}$, and Y_1 is complete to $Y_2 \cup Y_3 \cup \{t\}$.

- (b) If $X_1 \neq \emptyset$, then since X_1 is anticomplete to $(X \cup Y \cup Z \cup L) \setminus (X_1 \cup Y_1)$ (by 4.12.1, Lemma 4.9:(i), Lemma 4.9:(ii) and Lemma 4.9:(iv)) and since $\{v_1\}$ is not a cut-vertex of G separating X_1 and rest of the vertices, there are adjacent vertices, say $x \in X_1$ and $y \in Y_1$, and then $\{t, y, x, v_1, z\}$ induces a P_5 (by Lemma 4.1:(ii) and (a)), a contradiction. So $X_1 = \emptyset$.
- (c) Now we will show that X is complete to $Y_2 \cup Y_3 \cup \{t\}$. Let $x \in X_2$. If $xz \notin E(G)$, then by using a similar argument as in (a), we see that $\{x\}$ is complete to $Y_2 \cup \{t\}$, and if $xz \in E(G)$, then by using a similar argument as in Lemma 4.9:(iii), we see that $\{x\}$ is complete to $Y_2 \cup \{t\}$. Also, since for any $y \in Y_3$, $\{x, t, y, v_1, v_3\}$ does not induce a P_5 , $\{x\}$ is complete to Y_3 . Since x is arbitrary, X_2 is complete to $Y_2 \cup Y_3 \cup \{t\}$. Likewise, X_3 is complete to $Y_2 \cup Y_3 \cup \{t\}$. So X is complete to $Y_2 \cup Y_3 \cup \{t\}$ (by (b)).
- (d) From (a), (b), (c) and Lemma 4.1:(iii), we conclude that $V(Q)$ is complete to $X \cup Y$.
- (e) Next we will show that $L \setminus V(Q) = \emptyset$. Suppose not. Let $q \in L \setminus V(Q)$. Since for any $t' \in L \setminus V(Q)$ and for $j \in \{2, 3\}$, $\{v_j, z, t', y_j, t\}$ does not induce a P_5 (by Lemma 4.11), $L \setminus V(Q)$ is anticomplete to $\{z\}$. Likewise, $V(Q)$ is anticomplete to $\{z\}$. Then as in (c), the vertex-set of the component that contains q is complete to $X \cup Y_2 \cup Y_3$. Since $C \cup (Z \setminus \{z\})$ is not a clique cut-set of G separating $\{z\}$ and the rest of the vertices, there is a vertex in X , say x such that $xz \in E(G)$. Then $\{x, y_2, y_3, t, q\}$ induces a $K_5 - e$, a contradiction. Hence $L \setminus V(Q) = \emptyset$.

Now if $X_2 \cup X_3 \cup Y_1 \neq \emptyset$, then since Y_2, Y_3 and L are non-empty, by above arguments and Observation 6, $X \cup Y \cup L$ is a clique, and hence G is the complement of a bipartite graph (by Lemma 4.1:(i)), a contradiction; so we may assume that $X_2 \cup X_3 \cup Y_1 = \emptyset$. Then since $C \cup (Z \setminus \{z\})$ is not a clique cut-set separating $\{z\}$ from the rest of the vertices of G , there is a vertex in $V(Q) \setminus \{t\}$, say t' , such that $t'z \in E(G)$. Now since $Y_2, Y_3, \{t\}$ and $V(Q) \setminus \{t\}$ are non-empty, again by above arguments and Observation 6, $X \cup Y \cup L$ is a clique. So $V(G)$ can be partitioned into two cliques, namely $C \cup Z$ (by Lemma 4.1:(i)) and $X \cup Y \cup L$, and hence G is the complement of a bipartite graph, a contradiction. This proves the first assertion.

Now since L is complete to $\{z_1, z_2\}$, L induces a P_3 -free graph (by Observation 4). Moreover, by using Lemma 4.1:(ii), Lemma 4.1:(iii), Lemma 4.11 and Observation 5, we see that each component of $G[L]$ is K_3 -free. So L induces a (P_3, K_3) -free graph, which is a bipartite graph. This proves 4.12.2. ■

4.12.3 $Z = \{z_1, z_2\}$.

Proof of 4.12.3. If $L \neq \emptyset$ then $Z = \{z_1, z_2\}$ (by 4.12.2 and Lemma 4.3:(ii)). So we may assume that $L = \emptyset$. Suppose to the contrary that there is a vertex, say $z \in Z \setminus \{z_1, z_2\}$. Then $C \cup (Z \setminus \{z\})$ is a clique cut-set of G (by Lemma 4.1:(ii) and Lemma 4.9:(v)), a contradiction. This proves 4.12.3. ■

4.12.4 $G[X_2 \cup Y_3]$ is K_3 -free. Likewise, $G[X_3 \cup Y_2]$, $G[X_1]$ and $G[Y_1]$ are K_3 -free.

Proof of 4.12.4. Suppose not. Let Q be a component of $G[X_2 \cup Y_3]$ which contains a K_3 with vertices, say p, q and r . We may assume that $V(Q)$ is anticomplete to $\{z_1\}$ (by Lemma 4.9:(v)). Moreover, we claim that $V(Q)$ is anticomplete to $X_1 \cup X_3 \cup Y_1 \cup Y_2 \cup Z \cup L$, and we will prove using a sequence of arguments given below.

- (a) First we will show that $V(Q)$ is a homogeneous set in $G[V(Q) \cup Y_1 \cup Y_2]$. If not, then there are vertices, say $a, b \in V(Q)$ and $c \in Y_1 \cup Y_2$ such that $ab, ac \in E(G)$ and $bc \notin E(G)$, and then $\{b, a, c, v_3, z_1\}$ induces a P_5 (by Lemma 4.1:(ii)), a contradiction. So $V(Q)$ is a homogeneous set in $G[V(Q) \cup Y_1 \cup Y_2]$.
- (b) If there is a vertex, say $y \in Y_2$, which has a neighbor in $V(Q)$, then $\{y\}$ is complete to $\{p, q, r\}$ (by (I)), and then $\{p, q, r, v_2, y\}$ induces a $K_5 - e$; so $V(Q)$ is anticomplete to Y_2 .
- (c) $V(Q)$ is anticomplete to Z (by (b), Lemma 4.1:(ii) and Lemma 4.9:(iii)), $V(Q)$ is anticomplete to Y_1 (by (a), Lemma 4.3:(i) and Lemma 4.9:(i)), and $V(Q)$ is anticomplete to X_1 (by Lemma 4.9:(i) and Lemma 4.9:(iv)).
- (d) By (c), Lemma 4.1:(ii) and Lemma 4.9:(v), there is a vertex in Z , say z' such that $\{z'\}$ is anticomplete to $V(Q) \cup X_3$. Then by using similar arguments in (a) and (b), we see that $V(Q)$ is anticomplete to X_3 .
- (e) Finally we show that $V(Q)$ is anticomplete to L . Suppose not. Then there are adjacent vertices, say $t \in L$ and $u \in V(Q)$. Now since $\{t, u, v_2, v_3, y_2\}$ does not induce a P_5 (by (b)), we have $ty_2 \in E(G)$. Then since $G[\{p, q, r, v_2, v_3, y_2, t\}]$ does not contain a P_5 (by (b)), $\{t\}$ is complete to $\{p, q, r\}$. But then $\{p, q, r, t, v_2\}$ induces a $K_5 - e$, a contradiction. So $V(Q)$ is anticomplete to L .

Thus we conclude that $V(Q)$ is anticomplete to $X_1 \cup X_3 \cup Y_1 \cup Y_2 \cup Z \cup L$, and hence $\{v_1, v_2\}$ is a clique cut-set separating Q from the rest of the vertices of G , a contradiction. So 4.12.4 holds. ■

4.12.5 *If L is not anticomplete to X , then either $X_1 \cup X_2 \cup Y_1 = \emptyset$ or $X_1 \cup X_3 \cup Y_1 = \emptyset$.*

Proof of 4.12.5. Since L is not anticomplete to X , there are adjacent vertices, say $t \in L$ and $x \in X$. By Lemma 4.11, each vertex in L is adjacent to one of y_2 and y_3 , and L is complete to $\{z_1, z_2\}$ (by 4.12.2). So $x \notin X_1$ (by Lemma 4.1:(iii) and Lemma 4.9:(i)), and we may assume that $x \in X_2$. Then $X_1 = \emptyset$ (by Lemma 4.2:(i)) and $xy_3 \in E(G)$ (by Lemma 4.10), and hence $Y_1 = \emptyset$ (by Lemma 4.9:(i)).

Now it is enough to show that $X_3 = \emptyset$. Suppose not, and let $x' \in X_3$. We show that $X \cup Y \cup L$ is a clique. First we show that $X = \{x, x', y_2, y_3\}$. Observe that $xx', x't \in E(G)$ (by Lemma 4.2), and then $x'y_2 \in E(G)$ (by Lemma 4.10). So $X_2 \cup X_3$ is complete to $\{t\}$, and X_2 is complete to X_3 (by Lemma 4.2). Thus $X_2, Y_3, \{t\}$ and $\{y_2\}$ are complete to each other (by Lemma 4.10); so $X_2 \cup Y_3$ is a clique (by Observation 6), and hence $X_2 = \{x\}$ and $Y_3 = \{y_3\}$ (by 4.12.4). Likewise, $X_3 = \{x'\}$ and $Y_2 = \{y_2\}$. So $X = \{x, x', y_2, y_3\}$. Next we will show that L is complete to X . By Lemma 4.1:(iii) and Lemma 4.2, it is enough to show that L is complete to $\{x, x'\}$. Suppose not, and let $t' \in L$

be such that $\{t'\}$ is not complete to $\{x, x'\}$. So by Lemma 4.2:(i), $\{t'\}$ is anticomplete to $\{x, x'\}$. Recall that, by Lemma 4.11, t' is adjacent to one of y_2 and y_3 . If $t'y_2 \in E(G)$, then we may assume that $x'z_1 \notin E(G)$ (by Lemma 4.1:(iv)), and then $\{x', y_2, t', z_1, v_2\}$ induces a P_5 (by 4.12.2); so $t'y_2 \notin E(G)$ and hence $t'y_3 \in E(G)$. Then we assume that $xz_1 \notin E(G)$ (by Lemma 4.1:(iv)), and then $\{x, y_3, t', z_1, v_2\}$ induces a P_5 (by 4.12.2), a contradiction. So L is complete to $\{x, x', y_2, y_3\}$. So by above arguments and by Observation 6, we conclude that $X \cup Y \cup L$ is a clique. Thus $V(G)$ can be partitioned in two disjoint cliques, namely, $X \cup Y \cup L$ and $C \cup Z$, and hence G is the complement of a bipartite graph, a contradiction. So 4.12.5 holds. ■

By 4.12.4 and Theorem A, for $i \in \{1, 2, 3\}$: we pick a maximum stable set from each 5-ring-component of $G[X_i]$ (if exists), and let A_i be the union of these sets. So $G[X_i \setminus A_i]$ is a bipartite graph. Next, we pick a maximum stable set from each big-component of $G[X_i \setminus A_i]$ (if exists), and let B_i be the union of these sets. Let $X'_i = X_i \setminus (A_i \cup B_i)$. Also, let Y'_i be a maximal stable set in $G[Y_i]$. Then $Y_i \setminus Y'_i$ is a stable set (by 4.12.4 and Lemma 4.1:(ii)). Now we claim the following:

4.12.6 For $j, \ell \in \{2, 3\}$ and $j \neq \ell$, $A_j \cup B_j$ is anticomplete to $X_\ell \cup Z$.

Proof of 4.12.6. We will show for $j = 2$. Suppose to the contrary there are adjacent vertices, say $a \in A_2 \cup B_2$ and $b \in X_3 \cup Z$. Moreover there is a vertex, say $c \in X'_2 \setminus A_2$, such that $ac \in E(G)$. Now $ay_3, cy_3 \notin E(G)$ (by 4.12.4 and Lemma 4.1:(iii)), and so $b \in X_3$, $az_1, az_2 \notin E(G)$ (by Lemma 4.9:(iii)). Also we may assume that $bz_1 \notin E(G)$ (by Lemma 4.9:(v)). Then since $\{a, b, v_3, v_1, y_3\}$ does not induce a P_5 , we have $by_3 \in E(G)$, and then $\{a, b, y_3, v_1, z_1\}$ induces a P_5 , contradiction. So 4.12.6 holds. ■

By 4.12.2, L can be partitioned in two stable sets, say L_1 and L_2 , and we may assume that if L is not anticomplete to X , then $X_1 \cup X_3 \cup Y_1 = \emptyset$ (by 4.12.5). Now we define the following sets: $S_1 := X'_2 \cup B_3 \cup Y'_1 \cup \{v_1\}$, $S_2 := B_1 \cup X'_3 \cup L_2 \cup \{v_2\}$, $S_3 := X'_1 \cup B_2 \cup L_1 \cup \{v_3\}$, $S_4 := A_1 \cup A_3 \cup Y'_2 \cup (Y_1 \setminus Y'_1) \cup (Y_3 \setminus Y'_3) \cup \{z_1\}$ and $S_5 := A_2 \cup (Y_2 \setminus Y'_2) \cup Y'_3 \cup \{z_2\}$. Then $V(G) = \bigcup_{j=1}^5 S_j$ (by 4.12.3), and we claim the following:

4.12.7 S_1, S_2, \dots, S_5 are stable sets.

Proof of 4.12.7. Clearly S_1 is a stable set (by 4.12.6 and Lemma 4.9:(i)), and S_2 is a stable set (by 4.12.1, 4.12.5 and Lemma 4.9:(iv)). Now if there are adjacent vertices, say $a \in B_2$ and $t \in L_1$, then $ay_3 \in E(G)$ (by 4.12.2 and Lemma 4.10:(i)), and for any neighbor of a in X'_2 , say x , we have $xy_3 \in E(G)$ (by Lemma 4.1:(iii)), and hence $\{x, a, y_3\}$ induces a K_3 in $G[X_2 \cup Y_3]$, a contradiction to 4.12.4; so $B_2 \cup L_1$ is a stable set. This implies that S_3 is a stable set (by 4.12.1 and Lemma 4.9:(iv)).

Next $Y'_2 \cup (Y_1 \setminus Y'_1) \cup (Y_3 \setminus Y'_3) \cup \{z_1\}$ is a stable set (by Lemma 4.1:(ii), Lemma 4.3:(i) and by the definition of Y'_i), and $A_1 \cup A_3$ is anticomplete to $(Y_1 \setminus Y'_1) \cup (Y_3 \setminus Y'_3) \cup \{z_1\}$ (by Lemma 4.9:(i), Lemma 4.9:(ii), Lemma 4.3:(iv) and 4.12.6). Since every vertex of A_3 has a neighbor in X'_3 , A_3 is anticomplete to Y'_2 (by Lemma 4.1:(iii) and 4.12.4), and so $A_1 \cup A_3$ is anticomplete to Y'_2 (by

Lemma 4.9:(i)). Also A_1 is anticomplete to A_3 (by Lemma 4.9:(iv)). Thus we conclude that S_4 is a stable set. Likewise, S_5 is also a stable set. This proves 4.12.7. ■

So we conclude that $\chi(G) \leq 5$ (by 4.12.7). This completes the proof of Theorem 4.12. □

We note that the graph G_3 (see Figure 17) is an imperfect $(P_5, K_5 - e)$ -free graph which has no clique cut-set and contains an F_2 with $\chi(G_3) = \omega(G_3) = 5$. Thus, the bound given in Theorem 4.12 is tight.

4.4.3 $(P_5, K_5 - e, F_1, F_2)$ -free graphs that contain an F_3

Let G be a connected $(P_5, K_5 - e, F_1, F_2)$ -free graph which has no clique cut-set. Suppose that G contains an F_3 with vertices and edges as shown in Figure 16. Let $C := \{v_1, v_2, v_3\}$. Then, with respect to C , we define the sets X, Y, Z and L as in Section 4.3, and we use the lemmas in Section 4.3. Clearly $y_2 \in Y_2, y_3 \in Y_3$ and $z_1, z_2 \in Z$ so that Y_2, Y_3 and Z are non-empty. Recall that $C \cup Z$ is a clique (by Lemma 4.1:(i)), and that Y is anticomplete to Z (by Lemma 4.1:(ii)). Further the graph G has some more properties which we give in Lemmas 4.13 and 4.14 below.

Lemma 4.13 *For $i \in \{1, 2, 3\}$, the following hold:*

- (i) Y_i is anticomplete to $Y_{i+1} \cup Y_{i-1}$.
- (ii) X_1 is anticomplete to $Y_2 \cup Y_3$. Likewise, if $Y_1 \neq \emptyset$, then for all $i \in \{1, 2, 3\}$, X_i is anticomplete to $Y_{i+1} \cup Y_{i-1}$.
- (iii) Either X_i is anticomplete to $Y_{i+1} \cup Y_{i-1}$ or X_i is anticomplete to Y_i .
- (iv) If a vertex of L has a neighbor in Y_i , then it is complete to $Y \cup Z$. Moreover, $G[Y_i]$ is a bipartite graph and $Z = \{z_1, z_2\}$.
- (v) If one of X_2 and X_3 is empty, then L is not anticomplete to Y .

Proof. (i): If there are adjacent vertices, say $y \in Y_i$ and $y' \in Y_{i+1} \cup Y_{i-1}$, then $\{v_1, v_2, v_3, y, y', z_1, z_2\}$ induces an F_2 . So Lemma 4.13:(i) holds. ■

(ii): Suppose to the contrary that there are adjacent vertices, say $x \in X_1$ and $y \in Y_2 \cup Y_3$. We may assume (up to symmetry) that $y \in Y_2$, and we may assume that $xz_1 \notin E(G)$ (by Lemma 4.1:(iv)). Then one of $\{x, y, v_3, v_2, y_3\}$ or $\{y, x, y_3, v_2, z_1\}$ induces a P_5 (by Lemma 4.1:(ii) and Lemma 4.13:(i)), a contradiction. So Lemma 4.13:(ii) holds. ■

(iii): By Lemma 4.13:(ii), it is enough to show for $i \in \{2, 3\}$. We will show for $i = 2$. Suppose to the contrary that the assertion is not true. Then, by using Lemma 4.13:(ii), we may assume that there are vertices, say $x, x' \in X_2, y \in Y_3$ and $y' \in Y_2$ such that $xy, x'y' \in E(G)$. Also we may assume that $xz_1 \notin E(G)$ (by Lemma 4.1:(iv)). Then since $\{y, x, y', v_3, z_1\}$ does not induce a P_5 , we have $xy' \notin E(G)$; so $x \neq x'$. Likewise, $x'y \notin E(G)$. Then $xx' \notin E(G)$ (by Lemma 4.1:(iii)), and then $\{x, y, v_1, y', x'\}$ induces a P_5 (by Lemma 4.13:(i)), a contradiction. So Lemma 4.13:(iii) holds. ■

(iv): Clearly the first assertion follows from Lemma 4.3:(iii) and Lemma 4.13:(i). Now if a vertex in L , say t , has a neighbor in Y_i , then since $\{t, v_{i+1}\}$ is complete to Y_i , $G[Y_i]$ is a bipartite graph (by Lemma 4.1:(ii) and Observation 5), and since $\{t\}$ is complete to Z , we have $Z = \{z_1, z_2\}$ (by Lemma 4.3:(ii)). This proves Lemma 4.13:(iv). ■

(v): We may assume that $X_2 = \emptyset$. Suppose to the contrary that Y is anticomplete to L . By Lemma 4.13:(iii), X_3 is anticomplete to one of Y_2 or Y_3 . Then by Lemma 4.13:(i) and Lemma 4.13:(ii), either Y_2 is anticomplete to $V(G) \setminus (Y_2 \cup \{v_1, v_3\})$ or Y_3 is anticomplete to $V(G) \setminus (Y_3 \cup \{v_1, v_2\})$. But now C is a clique cut-set in G separating one of Y_2 or Y_3 with the rest of the vertices in G , a contradiction. So L is not anticomplete to Y . This proves Lemma 4.13:(v). □

Lemma 4.14 *If there is an $i \in \{1, 2, 3\}$ such that X_i is not anticomplete to $Y_{i+1} \cup Y_{i-1}$, then $\chi(G) \leq 5$.*

Proof. By Lemma 4.13:(ii), we may assume that $i = 2$, and there are adjacent vertices, say $p \in X_2$ and $q \in Y_1 \cup Y_3$. Again, by Lemma 4.13:(ii), we have $Y_1 = \emptyset$ and so $q \in Y_3$. Also, X_2 is anticomplete to Y_2 (by Lemma 4.13:(iii)). Moreover, we claim that:

4.14.1 $X_3 = \emptyset$.

Proof of 4.14.1: Suppose not, and let $x \in X_3$. By Lemma 4.1:(iv), we may assume that $xz_1 \notin E(G)$. Since $\{v_1, v_2, v_3, z_1, z_2, p, q\}$ does not induce an F_2 , $pz_1 \notin E(G)$. Then since $\{p, q, v_1, v_3, x\}$ or $\{p, q, x, v_3, z_1\}$ does not induce a P_5 , we have $px, qx \in E(G)$. Thus by Lemma 4.13:(iii), $xy_2 \notin E(G)$. But then $\{x, p, v_2, v_1, y_2\}$ induces a P_5 , a contradiction. So 4.14.1 holds. ■

By 4.14.1 and by Lemma 4.13:(v), there is a vertex, say $t \in L$, that has a neighbor in Y . Then by Lemma 4.13:(iv), $\{t\}$ is complete to Y , $G[Y_2]$ is a bipartite graph, and $Z = \{z_1, z_2\}$. Then since for any $x \in X_2$, $\{t, y_2, v_3, v_2, x\}$ does not induce a P_5 , $\{t\}$ is complete to X_2 . So X_2 is complete to Y_3 (by Lemma 4.1:(iii)). Now for any $x' \in X_2$ which has a neighbor in Z , say z_1 , since $\{v_1, v_2, z_1, v_3, z_2, x', q\}$ does not induce an F_2 (by Lemma 4.1:(ii) and Lemma 4.1:(iv)), we see that X_2 is anticomplete to Z . Thus if there are adjacent vertices, say u and v in X_2 , then $\{u, v, y_3, v_2, t\}$ induces a $K_5 - e$; so X_2 is a stable set. Likewise, Y_3 is a stable set. Also by Lemma 4.1:(iii) and Lemma 4.13:(ii), $\{t\}$ is anticomplete to X_1 , and hence $X_1 = \emptyset$ (by Lemma 4.2:(i)). So we conclude that $X \cup Y \cup Z = X_2 \cup Y_2 \cup Y_3 \cup \{z_1, z_2\}$, and $\chi(G[X \cup Y \cup Z]) \leq 2$. Next we claim that:

4.14.2 L is complete to Y .

Proof of 4.14.2. Suppose to the contrary that there is a component of $G[L]$, say Q , such that $V(Q)$ is not complete to Y . Thus by Lemma 4.1:(iii) and Lemma 4.13:(iv), $V(Q)$ is anticomplete to Y . So by Lemma 4.1:(iii) and Lemma 4.2:(i), $V(Q)$ is anticomplete to $X \cup Y$, and hence Z is a clique cut-set in G separating C and $V(Q)$, a contradiction. So 4.14.2 holds. ■

By 4.14.2, L is complete to $\{y_2, y_3\}$. So by Observation 5 and Theorem A, we conclude that $\chi(G[C \cup L]) \leq 3$, and hence $\chi(G) \leq 5$. This proves Lemma 4.14. □

Now we prove the main theorem of this subsection, and is given below.

Theorem 4.15 *Let G be a connected $(P_5, K_5 - e, F_1, F_2)$ -free graph. If G contains an F_3 , then either G has a clique cut-set or $\chi(G) = 5$.*

Proof. Let G be a connected $(P_5, K_5 - e, F_1, F_2)$ -free graph. Suppose that G contains an F_3 with vertices and edges as shown in Figure 16. Let $C := \{v_1, v_2, v_3\}$. Then, with respect to C , we define the sets X, Y, Z and L as in Section 4.3, and we use the lemmas in Section 4.3. Clearly $y_2 \in Y_2$ and $y_3 \in Y_3$, and $z_1, z_2 \in Z$, so that Y_2, Y_3 and Z are non-empty. Recall that $C \cup Z$ is a clique (by Lemma 4.1:(i)), and that Y is anticomplete to Z (by Lemma 4.1:(ii)). We may assume that G has no clique cut-set. Now since $\chi(F_3) = 5$, we have $\chi(G) \geq 5$, it is enough to show that $\chi(G) \leq 5$. By Lemma 4.14, we may assume that for each $i \in \{1, 2, 3\}$, X_i is anticomplete to $Y_{i+1} \cup Y_{i-1}$. Next we claim the following:

4.15.1 *X is anticomplete to L .*

Proof of 4.15.1. Suppose to the contrary there are adjacent vertices, say $x \in X$ and $t \in L$. If $x \in X_2$, then by Lemma 4.1:(iii), $ty_3 \notin E(G)$, so $\{t\}$ is anticomplete to Y (by Lemma 4.13:(iv)), and then one of $\{t, x, y_2, v_1, y_3\}$, $\{t, x, v_2, v_3, y_2\}$ induces a P_5 ; so $x \notin X_2$. Likewise, $x \notin X_3$. Thus $x \in X_1$. So by Lemma 4.2:(i), $X_2 \cup X_3 = \emptyset$. Now let $L' := \{t \in L \mid t \text{ has a neighbor in } X_1\}$. Then L' is anticomplete to $Y_2 \cup Y_3 \cup (L \setminus L')$ (by Lemma 4.1:(iii)), and for any $y' \in Y_1$, since one of $\{t, x, v_1, v_3, y'\}$, $\{t, x, y', v_3, y_2\}$ does not induce a P_5 , we have $Y_1 = \emptyset$. But, then $C \cup Z$ is a clique cut-set separating $X_1 \cup L'$ and the rest of the vertices in G , a contradiction. So 4.15.1 holds. ■

4.15.2 *L is complete to $Y \cup Z$, and $G[L]$ is a bipartite graph.*

Proof of 4.15.2. Since $C \cup Z$ is not a clique cut-set in G , the vertex-set of each component of $G[L]$ is not anticomplete to Y . So by Lemma 4.13:(iv) and Lemma 4.1:(iii), L is complete to $Y \cup Z$. In particular, L is complete to $\{y_2, y_3, z_1, z_2\}$. Now the second assertion follows from Observation 4 and Observation 5. This proves 4.15.2. ■

To prove the our theorem, we first suppose that there is an index $j \in \{1, 2, 3\}$ such that $X_{j+1} \cup X_{j-1} = \emptyset$. Then by Lemma 4.13:(v), $L \neq \emptyset$ and let $t \in L$. Thus by Lemma 4.13:(iv) and 4.15.2, $G[Y_i]$ is a bipartite graph for each i , and $Z = \{z_1, z_2\}$. For $i \in \{1, 2, 3\}$, let Y'_i be a maximal stable set in $G[Y_i]$. Next if $Y_j = \emptyset$, then since X_j is anticomplete to $Y_{j+1} \cup Y_{j-1} \cup L$ (by 4.15.1), $C \cup Z$ is a clique cut-set in G separating X_j and the rest of the vertices, a contradiction; so $Y_j \neq \emptyset$. Also for any $x \in X_j$ and $y \in Y_j$, since $\{x, v_j, v_{j+1}, y, t\}$ does not induce a P_5 (by 4.15.2), X_j is complete to Y_j . Then since X_j is complete to $Y_j \cup \{v_j\}$, $G[X_j]$ is K_3 -free (by Observation 5). Now by using Theorem A, we pick a maximum stable set from each 5-ring-component of $G[X_j]$ (if exists), and let S be the union of these sets; so $\chi(G[X_j \setminus S]) \leq 2$. Also $S \cup (Y_j \setminus Y'_j) \cup \{z_1\}$ is a stable set (by Lemma 4.3:(iv) and Lemma 4.3:(v)). Then from 4.15.1 and 4.15.2, we have $\chi(G[(X_j \setminus S) \cup L \cup \{v_{j+1}, v_{j-1}\}]) = 2$, and from Lemma 4.1:(ii) and Lemma 4.13:(i), we have $\chi(G[S \cup (Y \setminus (Y'_1 \cup Y'_2 \cup Y'_3)) \cup \{z_1\}]) = 1$ and $\chi(G[Y'_1 \cup Y'_2 \cup Y'_3 \cup \{z_2\}]) = 1$. So

we conclude that $\chi(G) = \chi(G[C \cup X_j \cup Y \cup \{z_1, z_2\} \cup L]) \leq 5$, and we are done. So we may assume that for each $j \in \{1, 2, 3\}$, either $X_{j+1} \neq \emptyset$ or $X_{j-1} \neq \emptyset$. To proceed further, we let $M := \{x \in X_1 \mid N(x) \cap X_2 \neq \emptyset\}$. Then:

4.15.3 *The following hold:*

- (i) X_2 and X_3 are non-empty.
- (ii) X_2 is complete to X_3 .
- (iii) X_2 is complete to Y_2 . Likewise, X_3 is complete to Y_3 .

Proof of 4.15.3. (i): Suppose not, and let $X_3 = \emptyset$. Then by our assumption $X_1, X_2 \neq \emptyset$. By Lemma 4.13:(v), $L \neq \emptyset$ and let $t \in L$. Since for any $x \in X_1$ and $x' \in X_2$, $\{x, x', v_2, y_3, t\}$ does not induce a P_5 (by 4.15.2), X_1 is anticomplete to X_2 . Now by 4.15.1, since $C \cup Z$ is not a clique cut-set in G , X_1 is not anticomplete to Y_1 , and X_2 is not anticomplete to Y_2 . Let $p \in X_1, q \in X_2, r \in Y_1$ and $s \in Y_2$ be such that $pr, qs \in E(G)$. Then $\{p, r, v_3, s, q\}$ induces a P_5 (by Lemma 4.13:(i)). So 4.15.3:(i) holds. ■

(ii): Suppose to the contrary there are non-adjacent vertices, say $p \in X_2$ and $q \in X_3$. Then for any $u \in Y_2$ and $v \in Y_3$, since $\{p, u, v_1, v, q\}$ does not induce a P_5 (by Lemma 4.13:(i)), we see that either $\{p\}$ is anticomplete to Y_2 or $\{q\}$ is anticomplete to Y_3 . We may assume that $\{p\}$ is anticomplete to Y_2 . Then for any $x \in X_1$, since $\{x, p, v_2, v_3, y_2\}$ does not induce a P_5 (by Lemma 4.13:(ii)), $\{p\}$ is anticomplete to X_1 . Likewise, $\{p\}$ is anticomplete to X_3 . But now if Q is the component of $G[X_2]$ that contains p , then $C \cup Z$ is a clique cut-set separating $V(Q)$ and the rest of the vertices in G (by Lemma 4.1:(iii) and 4.15.1), a contradiction. So 4.15.3:(ii) holds. ■

(iii): If there are non-adjacent vertices, say $x \in X_2$ and $y \in Y_2$, then for any $x_3 \in X_3$ (such a vertex exists, by (i)), $\{x_3, x, v_2, v_1, y\}$ induces a P_5 (by (ii)); so X_2 is complete to Y_2 . So 4.15.3:(iii) holds. ■

4.15.4 *The following hold:*

- (i) $X_1 \setminus M$ is complete to X_3 .
- (ii) Each vertex in Z is complete to exactly one of X_2 and X_3 .
- (iii) Each vertex in Z is complete to exactly one of X_3 and $X_1 \setminus M$.

Proof of 4.15.4. (i): If there are non-adjacent vertices, say $x \in X_1 \setminus M$ and $x' \in X_3$, then for any $x_2 \in X_2$, $\{x', x_2, v_2, v_1, x\}$ induces a P_5 (by 4.15.3:(i) and 4.15.3:(ii)). So 4.15.4:(i) holds. ■

(ii): Let $z \in Z$ and let $z \neq z_1$. If $\{z\}$ is complete to both X_2 and X_3 , then there are vertices, say $x_2 \in X_2$ and $x_3 \in X_3$ such that $zx_2, zx_3 \in E(G)$, and then $\{z, v_2, v_3, v_1, z_1, x_2, x_3\}$ induces an F_2 (by 4.15.3:(ii)); so $\{z\}$ is not complete to X_2 or X_3 . Suppose that there is a vertex, say $x \in X_2$ such that $zx \notin E(G)$. Now if there is a vertex, say $x' \in X_3$ such that $x'z \notin E(G)$, then $\{x, x', y_3, v_1, z\}$ induces a P_5 (by 4.15.3). So 4.15.4:(ii) holds. ■

(iii): This follows from a similar argument in 4.15.4:(ii) by using 4.15.4:(i) instead of 4.15.3. ■

By 4.15.3:(i), we let $x_2 \in X_2$ and $x_3 \in X_3$. From 4.15.4:(ii), we may assume that $\{z_1\}$ is complete to X_2 . Then $\{z_2\}$ is anticomplete to X_2 (by Lemma 4.1:(iv)). So $\{z_2\}$ is complete to X_3 (by 4.15.4:(ii)) and hence anticomplete to $X_1 \setminus M$ (by 4.15.4:(iii)). Next we claim that:

4.15.5 M is complete to $\{z_2\} \cup X_2$, and is anticomplete to $\{z_1\} \cup X_3$.

Proof of 4.15.5. Let $m \in M$, and let $x \in X_2$ be a neighbor of m . Then since $\{m, x, y_2, v_3, z_2\}$ does not induce a P_5 (by 4.15.3:(iii)), $mz_2 \in E(G)$; so M is complete to $\{z_2\}$. Thus M is anticomplete to $\{z_1\}$ (by Lemma 4.1:(iv)). Now if there are adjacent vertices, say $p \in X_3$ and $q \in M$, then $\{z_2, v_1, v_3, z_1, v_2, p, q\}$ induces an F_2 , a contradiction; so M is anticomplete to X_3 . Next if there are non-adjacent vertices, say $u \in M$ and $v \in X_2$, then $\{x_3, v, v_2, v_1, u\}$ induces P_5 (by 4.15.3:(ii)) and since $ux_3 \notin E(G)$ by the previous argument). This proves 4.15.5. ■

4.15.6 Then following hold:

- (i) $Z = \{z_1, z_2\}$.
- (ii) $Y_1 = \emptyset$.
- (iii) If $X_1 \neq \emptyset$, then $L = \emptyset$.

Proof of 4.15.6. (i): If there is a vertex, say $z \in Z \setminus \{z_1, z_2\}$, then $\{z\}$ is complete to exactly one of X_2 and X_3 (by 4.15.4:(ii)) which is a contradiction to Lemma 4.1:(iv). This proves 4.15.6:(i). ■

(ii): Suppose not. Then since C is not a clique cut-set separating Y_1 and the rest of the vertices, there are adjacent vertices, say $y \in Y_1$ and $p \in X_1 \cup L$. Then by 4.15.1, 4.15.3 and 4.15.5, if $p \in L$, then $\{x_2, x_3, v_3, y, p\}$ induces P_5 , if $p \in M$, then $\{y, p, x_2, x_3, y_3\}$ induces a P_5 , and if $p \in X_1 \setminus M$, then $\{y, p, x_3, x_2, y_2\}$ induces a P_5 . These contradictions imply that 4.15.6:(ii) holds. ■

(iii): Otherwise, for any $t \in L$ and $p \in X_1$, from 4.15.2 and 4.15.5, $\{p, x_2, v_2, y_3, t\}$ induces a P_5 (if $p \in M$), and from 4.15.2 and 4.15.4:(i), $\{p, x_3, v_3, y_2, t\}$ induces a P_5 (if $p \in X_1 \setminus M$). ■

4.15.7 $G[Y_2]$, $G[Y_3]$, $G[X_2]$, $G[X_3]$, $G[M]$ and $G[X_1 \setminus M]$ are bipartite.

Proof of 4.15.7. We show that, up to symmetry, $G[Y_2]$, $G[X_2]$ and $G[M]$ are bipartite. Recall that Y_2 is complete to $\{x_2, v_1, v_3\}$ (by 4.15.3:(iii)), X_2 is complete to $\{x_3, v_2, z_1\}$ (by 4.15.3:(ii)), and M is complete to $\{x_2, v_1, z_2\}$ (by 4.15.5). Now the proof follows from Observation 4 and Observation 5. ■

By above claims, since $G[M \cup X_3 \cup Y_2 \cup \{v_2, z_1\}]$ and $G[(X_1 \setminus M) \cup X_2 \cup Y_3 \cup \{v_3, z_2\}]$ are bipartite, if $X_1 \neq \emptyset$, then $\chi(G) \leq 5$ (by 4.15.6). So we may assume that $X_1 = \emptyset$. For $j \in \{2, 3\}$, let Y'_j , X'_j and L' respectively denote a maximal stable set of $G[Y_j]$, $G[X_j]$ and L . Then we define the following sets: $S_1 := X'_2 \cup Y'_3 \cup \{z_2\}$, $S_2 := X'_3 \cup Y'_2 \cup \{v_2\}$, $S_3 := (X_2 \setminus X'_2) \cup L' \cup \{v_3\}$, $S_4 := (X_3 \setminus X'_3) \cup (L \setminus L') \cup \{v_1\}$ and $S_5 := (Y_2 \setminus Y'_2) \cup (Y_3 \setminus Y'_3) \cup \{z_1\}$. Then by above arguments, S_i 's are stable sets whose union is $V(G)$. So $\chi(G) \leq 5$. This completes the proof of Theorem 4.15. □

We note that the graph G_4 (see Figure 17) is an imperfect $(P_5, K_5 - e)$ -free graph which has no clique cut-set and contains an F_2 with $\chi(G_3) = \omega(G_3) = 5$. So the assumption that G is F_2 -free in Theorem 4.15 cannot be dropped.

4.5 $(P_5, K_5 - e)$ -free graphs that contain a K_4

In this section, we deal with $(P_5, K_5 - e)$ -free graphs assuming that G is (F_1, F_2, F_3) -free (see Figure 16), and $\omega(G) \geq 4$.

4.5.1 $(P_5, K_5 - e, F_1, F_2, F_3)$ -free graphs with $\omega \geq 5$

Theorem 4.16 *Let G be a connected $(P_5, K_5 - e, F_1, F_2, F_3)$ -free graph with $\omega(G) \geq 5$. Then either G is the complement of a bipartite graph or G has a clique cut-set or $\chi(G) \leq 6$.*

Proof. Let G be a connected $(P_5, K_5 - e, F_1, F_2, F_3)$ -free graph. We may assume that G has no clique cut-set, and that G is not the complement of a bipartite graph. By Theorem 4.4, we assume that G contains an \mathbb{H}_2 , say K . Let $V(K) := \{v_1, v_2, v_3, z_1, z_2, y_1\}$ where $\{v_1, v_2, v_3, z_1, z_2\}$ induces a K_5 , and $N_K(y_1) = \{v_2, v_3\}$. Let $C := \{v_1, v_2, v_3\}$. Then with respect to C , we define the sets X, Y, Z and L as in Section 4.3, and we use the lemmas in Section 4.3. Clearly $y_1 \in Y_1$ and $z_1, z_2 \in Z$ so that Y_1 and Z are non-empty. Recall that $C \cup Z$ is a clique (by Lemma 4.1:(i)), and that Y is anticomplete to Z (by Lemma 4.1:(ii)). To proceed further, we let $Z_1 := \{z \in Z \mid \{z\} \text{ is anticomplete to } X_1\}$. We show that $\chi(G) \leq 6$. First we show that:

4.16.1 *The following hold:*

- (i) $Y_2 \cup Y_3 = \emptyset$.
- (ii) $X_1 \neq \emptyset$.
- (iii) $X_2 \cup X_3$ is anticomplete to Z .
- (iv) $|Z \setminus Z_1| \leq 1$.

Proof of 4.16.1. (i): If there is a vertex, say $y \in Y_2 \cup Y_3$, then $\{v_1, v_2, v_3, z_1, z_2, y, y_1\}$ induces an F_2 or an F_3 (by Lemma 4.1:(ii)). So 4.16.1:(i) holds. ■

(ii): If $X_1 = \emptyset$, then $Z \cup \{v_2, v_3\}$ is a clique cut-set separating $\{v_1\}$ and the rest of the vertices of G (by 4.16.1:(i) and Lemma 4.1:(i)), a contradiction. So 4.16.1:(ii) holds. ■

(iii): If there are adjacent vertices, say $x \in X_2 \cup X_3$ and $z' \in Z$ (and we may assume that $z' \neq z_1$, by Lemma 4.1:(iv)), then $\{z', v_2, v_3, v_1, z_1, y_1, x\}$ induces an F_2 or an F_3 , a contradiction. So 4.16.1:(iii) holds. ■

(iv): If there are vertices, say $z, z' \in Z$ and $x, x' \in X_1$ such that $zx, z'x' \in E(G)$, then $\{v_1, z, z', v_2, v_3, x, x'\}$ induces an F_2 or an F_3 (by Lemma 4.1:(iv)), a contradiction. So 4.16.1:(iv) holds. ■

Since $|Z| \geq 2$, we may assume that $z_1 \in Z_1$ (by 4.16.1:(iv)). Next we claim the following:

4.16.2 *Each vertex in Z_1 has a neighbor in L , and so $L \neq \emptyset$. Moreover, the vertex-set of each component of L is not anticomplete to $X_1 \cup Y_1$.*

Proof of 4.16.2. For any $z \in Z_1$, since $C \cup (Z \setminus \{z\})$ is not a clique cut-set separating $\{z\}$ and the rest of the vertices of G (by 4.16.1:(iii) and Lemma 4.1:(ii)), we see that each vertex in Z_1 has a neighbor in L . Since $z_1 \in Z_1$, we have $L \neq \emptyset$. This proves the first assertion.

To prove the second assertion, we let Q be an arbitrary component of $G[L]$. Since $C \cup Z$ is not a clique cut-set separating $V(Q)$ and the rest of the vertices of G , we see that $V(Q)$ is not anticomplete to $X \cup Y$. So from 4.16.1:(i), 4.16.1:(ii) and Lemma 4.2, it follows that $V(Q)$ is not anticomplete to $X_1 \cup Y_1$. This proves 4.16.2. ■

4.16.3 Z_1 is complete to L .

Proof of 4.16.3. Suppose to the contrary that there is a vertex in Z_1 , say z , such that $L \setminus N(z) \neq \emptyset$. We first show that $X \cup Y \cup L$ is a clique, and is given below.

- (a) First we observe that since every vertex of $L \setminus N(z)$ has a neighbor in $X_1 \cup Y_1$ (by 4.16.2), X_1, Y_1 and $L \setminus N(z)$ are complete to each other (by Lemma 4.3:(iii)).
- (b) $L \cap N(z)$ is complete to $L \setminus N(z)$: By 4.16.2, let $t' \in L \cap N(z)$ be arbitrary. Then by 4.16.2 and Lemma 4.1:(iii), let $u \in X_1 \cup Y_1$ be such that $ut' \in E(G)$. Since for any $v \in L \setminus N(z)$, one of $\{v_2, z, t', u, v\}$ or $\{v_1, z, t', u, v\}$ does not induce a P_5 (by (I)), $\{t'\}$ is complete to $L \setminus N(z)$. Thus $L \cap N(z)$ is complete to $L \setminus N(z)$.
- (c) From (a), (b) and from Lemma 4.1:(iii), $X_1 \cup Y_1$ is complete to L , where $L \cap N(z) \neq \emptyset$ and $L \setminus N(z) \neq \emptyset$.
- (d) From (III) and Lemma 4.2:(ii), it follows that X_1, X_2 and X_3 are complete to each other, and X is complete to L , and hence $X_2 \cup X_3$ is complete to Y_1 (by Lemma 4.1:(iii)).

From (c) and (d), and from 4.16.1:(i), we see that $X, Y, L \cap N(z)$ and $L \setminus N(z)$ are complete to each other, and since these sets are non-empty, we conclude that $X \cup Y \cup L$ is a clique (by Observation 6). So $V(G)$ can be partitioned into two cliques, namely, $X \cup Y \cup L$ and $C \cup Z$. Thus G is the complement of a bipartite graph, a contradiction. So 4.16.3 holds. ■

4.16.4 $G[L]$ is K_3 -free.

Proof of 4.16.4. Let Q be a component of $G[L]$. By 4.16.2, there is a vertex in $X_1 \cup Y_1$, say a , which has a neighbor in $V(Q)$. Then $\{a\}$ is complete to $V(Q)$ (by Lemma 4.1:(iii)). Now since $\{a, z_1\}$ is complete to $V(Q)$ (by 4.16.3), Q is K_3 -free (by Observation 5). Since Q is arbitrary, $G[L]$ is K_3 -free. This proves 4.16.4. ■

4.16.5 $|Z_1| \leq 2$.

Proof of 4.16.5. The proof follows from 4.16.2, 4.16.3 and Lemma 4.3:(ii). ■

4.16.6 $X_2 \cup X_3 = \emptyset$.

Proof of 4.16.6. Suppose not. If $X_2 \cup X_3$ is anticomplete to $X_1 \cup Y_1$, then $X_2 \cup X_3$ is anticomplete to L (by 4.16.1:(ii) and Lemma 4.2), and then $C \cup Z$ is a clique cut-set separating $X_2 \cup X_3$ and the rest of the vertices (by 4.16.1:(i)), a contradiction. So we may assume that X_2 is not anticomplete to $X_1 \cup Y_1$. To proceed further, we let $X'_2 := \{x \in X_2 \mid N(x) \cap (X_1 \cup Y_1) \neq \emptyset\}$. We first show that $X \cup Y_1 \cup L$ is a clique using a sequence of arguments given below.

- (a) X'_2, X_1 and Y_1 are complete to each other: Let $u \in X'_2$. For any $y \in Y_1 \cap N(u)$ and for any $x \in X_1$, since $\{u, y, v_3, v_1, x\}$ and $\{u, y, x, v_1, z_1\}$ do not induce P_5 's (by 4.16.1:(iii) and Lemma 4.1:(ii)), $(Y_1 \cap N(u)) \cup \{u\}$ is complete to X_1 . Likewise, $(X_1 \cap N(u)) \cup \{u\}$ is complete to Y_1 . Since one of $(X_1 \cap N(u))$ and $(Y_1 \cap N(u))$ is non-empty, it follows that X'_2 is complete to $X_1 \cup Y_1$, and X_1 is complete to Y_1 (by Lemma 4.1:(iii)).
- (b) X is complete to L and $X_2 = X'_2$: Suppose not. Then there is a vertex, say $t \in L$ such that t has a non-neighbor in X . By Lemma 4.2:(i), we may assume that $\{t\}$ is anticomplete to X . Then for any $x \in X_1$ and $x' \in X'_2$, since $\{x, x', v_2, z_1, t\}$ does not induce a P_5 (by (a), 4.16.1:(iii) and 4.16.3), we see that X is complete to L . This implies that X'_2 is complete to X_1 (by Lemma 4.2:(ii)) and so $X'_2 = X_2$.
- (c) Since X_2 is complete to L (by (b)), we have Y_1 is complete to L (by Lemma 4.1:(iii)) and hence again from Lemma 4.1:(iii), Y_1 is complete to X_3 . Also X_1 is complete to X_3 (by (b) and Lemma 4.2:(ii)).

By (a), (b) and (c), we conclude that X, Y_1 and L are complete to each other. Then since $Y, L \neq \emptyset$ and $|X| \geq 2$ (by 4.16.1:(ii) and 4.16.2), it follows from Observation 6 that $X \cup Y_1 \cup L$ is a clique. So by 4.16.1:(i), $V(G)$ can be partitioned into two cliques, namely, $X \cup Y \cup L$ and $C \cup Z$. Thus G is the complement of a bipartite graph, a contradiction. So 4.16.6 holds. ■

By 4.16.1 and 4.16.6, $V(G) = C \cup X_1 \cup Y_1 \cup Z \cup L$. Now we claim the following:

4.16.7 *The vertex-set of each component of $G[X_1]$ is a homogeneous set in $G[X_1 \cup Y_1 \cup L]$, and so $G[X_1]$ is K_3 -free.*

Proof of 4.16.7. If there are vertices, say $a, b \in X_1$ and $p \in Y_1 \cup L$ such that $ab, ap \in E(G)$ and $bp \notin E(G)$, then $\{b, a, p, v_2, z_1\}$ induces a P_5 (by 4.16.3 and Lemma 4.1:(ii)); so the first assertion holds.

To prove the second assertion, we let Q be a component of $G[X_1]$. Since $C \cup Z$ is not a clique cut-set separating $V(Q)$ and the rest of the vertices, $V(Q)$ is not anticomplete to $L \cup Y_1$. Let $t \in L \cup Y_1$ be such that $\{t\}$ is not anticomplete to $V(Q)$. So $V(Q)$ is complete to $\{t, v_1\}$, by the first assertion. Then from Observation 5, $V(Q)$ is K_3 -free. Since Q is arbitrary, $G[X_1]$ is K_3 -free. This proves 4.16.7. ■

4.16.8 *The vertex-set of each component of $G[Y_1]$ is a homogeneous set in G , and so $\chi(G[Y_1]) \leq 2$.*

Proof of 4.16.8. If there are vertices, say $a, b \in Y_1$ and $p \in V(G) \setminus Y_1$ such that $ab, ap \in E(G)$ and $bp \notin E(G)$, then $\{b, a, p, v_1, z_1\}$ induces a P_5 (by 4.16.3 and Lemma 4.1:(ii)); so the first assertion holds.

To prove the second assertion, let Q be a component of $G[Y_1]$. Since $\{v_2, v_3\}$ is not a clique cut-set separating $V(Q)$ and the rest of the vertices, $V(Q)$ is not anticomplete to $L \cup X_1$. Let $q \in L \cup X_1$ be such that $\{q\}$ is not anticomplete to $V(Q)$. Thus $V(Q)$ is complete to $\{q, v_2, v_3\}$, by the first assertion. Thus by Observation 4 and Observation 5, it follows that Q is (P_3, K_3) -free, and hence $\chi(Q) \leq 2$. This proves 4.16.8, since Q is arbitrary. ■

Now by using 4.16.7 and Theorem A, we pick a maximum stable set from each 5-ring-component of $G[X_1]$ (if exists), and let A be the union of these sets. Again by using 4.16.4 and Theorem A, we pick a maximum stable set from each 5-ring-component of $G[L]$ (if exists), and let B be the union of these sets. Note that A and B are stable sets, $\chi(G[X_1 \setminus A]) \leq 2$ and $\chi(G[L \setminus B]) \leq 2$ (by Theorem A). Let Y'_1 be a maximal stable set of $G[Y_1]$. Next we claim the following:

4.16.9 $A \cup B \cup (Y_1 \setminus Y'_1) \cup (Z_1 \setminus \{z_1\})$ is a stable set.

Proof of 4.16.9. Clearly $A \cup (Z_1 \setminus \{z_1\})$ and $(Y_1 \setminus Y'_1) \cup (Z_1 \setminus \{z_1\})$ are stable sets (by 4.16.5 and Lemma 4.1:(ii)). Suppose to the contrary that there are adjacent vertices, say $p, q \in A \cup B \cup (Y_1 \setminus Y'_1) \cup (Z_1 \setminus \{z_1\})$. First suppose that $p \in A$. Then $q \notin Z_1 \setminus \{z_1\}$. Let Q be the 5-ring-component of $G[X_1]$ such that $p \in V(Q)$. Since $q \in B \cup (Y_1 \setminus Y'_1)$, there is a vertex, say $r \in (L \setminus B) \cup Y'_1$ such that $qr \in E(G)$. Then by 4.16.7, 4.16.8 and Lemma 4.1:(iii), it follows that $\{q, r\}$ is complete to $V(Q)$. So by Observation 4, Q is P_3 -free, a contradiction.

So we may assume that $p \in B$ and $q \in (Y_1 \setminus Y'_1) \cup (Z_1 \setminus \{z_1\})$. Let Q' be the 5-ring-component of $G[L]$ such that $p \in V(Q')$. If $q \in Y_1 \setminus Y'_1$, then there is a vertex in Y'_1 , say y , such that $qy \in E(G)$, and hence $V(Q')$ is complete to $\{q, y\}$ (by 4.16.8 and Lemma 4.1:(iii)); so from Observation 4, Q' is P_3 -free, a contradiction. So $q \in Z_1 \setminus \{z_1\}$. Since $V(Q')$ is complete to $\{z_1, q\}$ (by 4.16.3), it follows from Lemma 4.1:(i) and Observation 4 that Q' is P_3 -free, a contradiction. So 4.16.9 holds. ■

So from 4.16.1:(iv), 4.16.8 and 4.16.9, we conclude that $\chi(G) \leq \chi(G[A \cup B \cup (Y_1 \setminus Y'_1) \cup (Z_1 \setminus \{z_1\})]) + \chi(G[(X_1 \setminus A) \cup \{z_1, v_2\}]) + \chi(G[(L \setminus B) \cup \{v_1, v_3\}]) + \chi(G[Y'_1 \cup (Z \setminus Z_1)]) \leq 1 + 2 + 2 + 1 = 6$. This completes the proof of Theorem 4.16. □

4.5.2 $(P_5, K_5 - e, F_1)$ -free graphs with $\omega = 4$

We begin with the following. Let G be a connected $(P_5, K_5 - e, K_5, F_1)$ -free graph which has no clique cut-set. Suppose that $\omega(G) = 4$. So G contains a K_4 , say K with vertices $\{v_1, v_2, v_3, z^*\}$. We let $C := \{v_1, v_2, v_3\}$. Then, with respect to C , we define the sets X, Y, Z and L as in Section 4.3, and we use the lemmas in Section 4.3. Clearly $z^* \in Z$, and so $Z \neq \emptyset$. For $i \in \{1, 2, 3\}$, we let $W_i := \{x \in X_i \mid xz^* \in E(G)\}$, and let $L_1 := \{t \in L \mid N(t) \cap X = \emptyset\}$. Recall that $C \cup Z$ is a clique (by Lemma 4.1:(i)), and that Y is anticomplete to (by Lemma 4.1:(ii)). Moreover, the graph G has some more properties which we give in a few lemmas below.

Lemma 4.17 *For $i \in \{1, 2, 3\}$, the following hold:*

- (i) *If $Y_{i+1} \cup Y_{i-1} \neq \emptyset$, and if $V(Q)$ is the vertex-set of a component of $G[X_i]$ which is anticomplete to L , then Q is K_3 -free.*
- (ii) *The vertex-set of each big-component of W_i is anticomplete to $Y_{i+1} \cup Y_{i-1}$.*
- (iii) *If Q is a 5-ring component of $G[X_i]$ (if exists), then $V(Q)$ is anticomplete to $Y_{i+1} \cup Y_{i-1}$, to the vertex-set of each big-component of $G[X_{i+1}]$, and to the vertex-set of each big-component of $G[X_{i-1}]$.*
- (iv) *If $X_i \setminus W_i$ is not anticomplete to Y_{i+1} , then $W_i \cup Y_{i-1} = \emptyset$. Likewise, if $X_i \setminus W_i$ is not anticomplete to Y_{i-1} , then $W_i \cup Y_{i+1} = \emptyset$.*

Proof. We will show for $i = 1$.

(i): If $V(Q)$ is complete to $\{z^*\}$, then since G is K_5 -free, clearly Q is K_3 -free. So by Lemma 4.3:(v), $\{z^*\}$ is anticomplete $V(Q)$. Then since the set $\{u \in V(G) \setminus V(Q) \mid N(u) \cap V(Q) \neq \emptyset\}$ is not a clique cut-set separating $V(Q)$ and the rest of the vertices, there are non-adjacent vertices, say $p, q \in V(G) \setminus V(Q)$ such that both p and q has neighbors in $V(Q)$. Then $\{p, q\}$ is complete to $V(Q)$ (by Lemma 4.1:(iii) and Lemma 4.3:(iv)). So Q is K_3 -free (by Observation 5). This proves Lemma 4.17:(i). ■

(ii): If there are vertices, say $w, w' \in W_1$ and $y \in Y_2 \cup Y_3$ such that $ww', wy \in E(G)$, then $\{w, w', v_1, y, z^*\}$ induces a $K_5 - e$ (by Lemma 4.1:(iii) and Lemma 4.3:(v)). So Lemma 4.17:(ii) holds. ■

(iii): If there is a vertex, say $y \in Y_2 \cup Y_3$ such that y has a neighbor in $V(Q)$, then $\{y\}$ is complete to $V(Q)$ (by Lemma 4.1:(iii)), and then $V(Q) \cup \{v_1, y\}$ induces a $K_5 - e$; so $V(Q)$ is anticomplete to $Y_2 \cup Y_3$. Other assertions follows from Observation 4 and Lemma 4.1:(iii). So Lemma 4.17:(iii) holds. ■

(iv): Suppose not, and let $w \in W_1 \cup Y_3$. If $w \in Y_3$, then G contains either a P_5 or an F_1 (and the proof is similar to the proof of Lemma 4.9:(i)). So we assume that $w \in W_1$. Since $X_1 \setminus W_1$ is not anticomplete to Y_2 , there are vertices, say $x \in X_1$ and $y \in Y_2$, such that $xy \in E(G)$ and $z^*x \notin E(G)$. Then by Lemma 4.3:(v), $wx \notin E(G)$. Now since $\{x, y, v_3, z^*, w\}$ does not induce a P_5 , $wy \in E(G)$, and then $\{x, y, w, z^*, v_2\}$ induces a P_5 , a contradiction. So Lemma 4.17:(iv) holds. □

Lemma 4.18 *The following hold:*

- (i) $Z = \{z^*\}$.
- (ii) *For $i \in \{1, 2, 3\}$, $G[Y_i]$ is the union of K_2 's and K_1 's.*
- (iii) $L \setminus L_1$ is anticomplete to L_1 . Moreover, $\chi(G[L]) \leq 3$.
- (iv) *If there is an $i \in \{1, 2, 3\}$ such that X_i, X_{i+1} and $L \setminus L_1$ are non-empty, then $\chi(G) \leq 7$.*

Proof. (i): Since G is K_5 -free, this follows from Lemma 4.1:(i). ■

(ii): Since $G[Y_i \cup \{v_{i+1}, v_{i-1}\}]$ does not induce a K_5 , $G[Y_i]$ is K_3 -free. Also since $G[Y_i]$ is P_3 -free (by Lemma 4.1:(ii)), we see that $G[Y_i]$ is the union of K_2 's and K_1 's. This proves Lemma 4.18:(ii). ■

(iii): Clearly $L \setminus L_1$ is anticomplete to L_1 (by Lemma 4.1:(iii)). To prove the second assertion, consider a component of $G[L]$, say Q . Then since $C \cup Z$ is not a clique cut-set separating $V(Q)$ and the rest of the vertices (by Lemma 4.1:(i)), there is a vertex, say $p \in X \cup Y$ which has a neighbor in $V(Q)$. Then $\{p\}$ is complete to $V(Q)$ (by Lemma 4.1:(iii)), and then since G is $(K_5, K_5 - e)$ -free, Q is $(K_4, K_4 - e)$ -free. Hence $\chi(Q) \leq 3$, by Theorem I. This proves Lemma 4.18:(iii), since Q is arbitrary. ■

(iv): We may assume that $i = 1$. Clearly $\chi(G[Y \cup Z]) \leq 3$ (by Lemma 4.3:(i), Lemma 4.18:(i) and Lemma 4.18:(ii)), and $\chi(G[L_1]) \leq 3$ (by Lemma 4.18:(iii)). Since $L \setminus L_1 \neq \emptyset$, it follows from Lemma 4.2 that X_1, X_2, X_3 and $L \setminus L_1$ are complete to each other. Then since G is $(K_5, K_5 - e)$ -free, it follows from Observation 4 that $G[X_1], G[X_2 \cup X_3]$ and $G[L \setminus L_1]$ are (P_3, K_3) -free, and hence bipartite. Also since G is K_5 -free, at least two of $X_1, X_2 \cup X_3$ and $L \setminus L_1$ are stable sets. Then since $\{v_2\}$ is anticomplete to X_1 , $\{v_1\}$ is anticomplete to $X_2 \cup X_3$, and $\{v_3\}$ is anticomplete to $L \setminus L_1$, we conclude that $\chi(G[C \cup X \cup (L \setminus L_1)]) \leq 4$. Clearly L_1 is anticomplete to $(L \setminus L_1) \cup X$ (by Lemma 4.1:(iii) and by the definition of L_1). So $\chi(G) \leq \chi(G[Y \cup Z]) + \chi(G[C \cup X \cup L]) = 3 + 4 = 7$. This proves Lemma 4.18:(iv). □

Lemma 4.19 *For $i \in \{1, 2, 3\}$: Define, $M = Y_i$ if Y_{i+1} and Y_{i-1} are non-empty, otherwise let $M = \emptyset$. If L is anticomplete to $X_{i+1} \cup X_{i-1}$, and if $G[X_{i+1}]$ and $G[X_{i-1}]$ are K_3 -free, then $G[X_{i+1} \cup X_{i-1} \cup M \cup L \cup \{v_i\}]$ is 4-colorable.*

Proof. Let $i = 1$. For $k \in \{2, 3\}$, we pick a maximum stable set from each 5-ring-component of $G[X_k]$ (by using Theorem A), and let A_k be the union of these sets. So $G[X_2 \setminus A_2]$ and $G[X_3 \setminus A_3]$ are bipartite graphs. For $k \in \{2, 3\}$, we pick a maximum stable set from each big-component of $G[X_k \setminus A_k]$, and let B_k be the union of these sets. By Lemma 4.18:(ii), we pick a maximum stable set from each big-component of $G[Y_1]$, and let D be the union of these sets. So $X_2 \setminus (A_2 \cup B_2)$, $X_3 \setminus (A_3 \cup B_3)$ and $Y_1 \setminus D$ are stable sets. Also $A_3 \cup B_2$ is stable set (by Lemma 4.17:(iii)), $B_2 \setminus W_2$ is anticomplete to Y_1 (by Lemma 4.17:(iv)), and $B_2 \cap W_2$ is anticomplete to Y_1 (by Lemma 4.17:(ii)). So $A_3 \cup B_2 \cup D \cup \{v_1\}$ is a stable set (by Lemma 4.17:(iii)). Likewise, $A_2 \cup B_3 \cup (Y_1 \setminus D)$ is also a stable set. To proceed further, we let $L' := \{t \in L \mid N(t) \cap D \neq \emptyset\}$, and we claim the following:

4.19.1 *L' is complete to the vertex-set of each big-component of $G[Y_1]$, and is anticomplete to $L \setminus L'$. Moreover, $G[L']$ is a bipartite graph.*

Proof of 4.19.1. Let Q be a big-component of $G[Y_1]$, and so $Q = K_2$ (by Lemma 4.18:(ii)). Suppose to the contrary that there are non-adjacent vertices, say $t \in L'$ and $y \in V(Q)$. Let $y' \in D$ be such that $y't \in E(G)$. Since $Y_2 \neq \emptyset$, we let $y_2 \in Y_2$. Then since $\{t, y', v_2, v_1, y_2\}$ does not induce a P_5 , we have $y_2t \in E(G)$ (by Lemma 4.3:(i)), and then $\{t, y_2, v_1, v_2, y\}$ induces a P_5 , a contradiction; so L' is complete to $V(Q)$. Then L' is anticomplete to $L \setminus L'$ (by Lemma 4.1:(iii)). Since L' is complete to D , there are adjacent vertices, say $p, q \in Y_1$ such that $\{p, q\}$ is complete to L' . So

$G[L']$ is P_3 -free (by Observation 4), and since G is K_5 -free, $G[L']$ is K_3 -free. Hence $G[L']$ is a bipartite graph. This proves 4.19.1. ■

By 4.19.1, there are stable sets, say L'_1 and L'_2 , such that $L' = L'_1 \cup L'_2$. By Lemma 4.18:(iii), there are three stable sets, say R_1, R_2 and R_3 such that $L \setminus L' = R_1 \cup R_2 \cup R_3$. Now define $S_1 := (X_2 \setminus (A_2 \cup B_2)) \cup L'_1 \cup R_1$, $S_2 := (X_3 \setminus (A_3 \cup B_3)) \cup L'_2 \cup R_2$, $S_3 := A_3 \cup B_2 \cup D \cup R_3 \cup \{v_1\}$ and $S_4 := A_2 \cup B_3 \cup (Y_1 \setminus D)$. Then by above arguments and by 4.19.1, we see that S_1, S_2, S_3 and S_4 are stable sets. So $\chi(G[X_2 \cup X_3 \cup M \cup L \cup \{v_1\}]) \leq 4$. This proves Lemma 4.19. □

Lemma 4.20 *If there is an $i \in \{1, 2, 3\}$ such that $Y_{i+1} \cup Y_{i-1} \neq \emptyset$, then $\chi(G[Y_i \cup L \cup \{v_i\}]) \leq 4$.*

Proof. The proof is similar to the proof of Lemma 4.19, and we omit the details. □

Lemma 4.21 *If G contains an F_4 , then $\chi(G) \leq 7$.*

Proof. Suppose that G contains an F_4 with vertices and edges as shown in Figure 16. Let $C := \{v_1, v_2, v_3\}$. Then, with respect to C , we define the sets X, Y, Z and L as in Section 4.3, and we use the lemmas in Section 4.3. We also use Lemmas 4.17 to 4.20. Clearly $y_2 \in Y_2$ and $y_3 \in Y_3$ so that Y_2 and Y_3 are non-empty. For each i , since $G[N(v_i)]$ is $(K_4 - e)$ -free, by Theorem I, we have $\chi(G[N(v_i)]) \leq 3$. Recall that $V(G) \setminus N(v_i) = \{v_i\} \cup X_{i+1} \cup X_{i+2} \cup Y_i \cup L$. Now if $L = L_1$, then $\chi(G) \leq 7$ (by Lemma 4.19) and we are done. So we may assume that $L \setminus L_1 \neq \emptyset$. Also using Lemma 4.18:(iv), we may assume that there is an index $k \in \{1, 2, 3\}$ such that X_{k+1} and X_{k-1} are empty. Then from Lemma 4.20, $\chi(G[Y_k \cup L \cup \{v_k\}]) \leq 4$, and so $\chi(G) \leq \chi(G[N(v_k)]) + \chi(G[V(G) \setminus N(v_k)]) \leq 7$. This proves Lemma 4.21. □

Lemma 4.22 *If G is F_4 -free, and contains an F_5 , then $\chi(G) \leq 7$.*

Proof. Suppose that G contains an F_5 with vertices and edges as shown in Figure 16. Let $C := \{v_1, v_2, v_3\}$. Then, with respect to C , we define the sets X, Y, Z and L as in Section 4.3, and we use the lemmas in Section 4.3. We also use Lemmas 4.17 to 4.20. Clearly $x_1 \in X_1$ and $y_2 \in Y_2$ so that X_1 and Y_2 are non-empty. For each i , since $G[N(v_i)]$ is $(K_4 - e)$ -free, by Theorem I, we have $\chi(G[N(v_i)]) \leq 3$. Now for any $y \in Y_1 \cup Y_3$, since $\{v_1, v_2, v_3, y_2, y, z^*\}$ does not induce an F_4 , $Y_1 \cup Y_3 = \emptyset$. Also for any $x \in X_1 \cup X_3$, since $\{v_1, v_2, v_3, x, y_2, z^*\}$ does not induce an F_4 , $X_1 \cup X_3$ is anticomplete to $\{z^*\}$. Since $\{v_1, v_3, z^*\}$ is not a clique cut-set separating $\{v_2\}$ and the rest of the vertices, we have $X_2 \neq \emptyset$. Now if $L \setminus L_1 \neq \emptyset$, then $\chi(G) \leq 7$ (by Lemma 4.18:(iv)) and we are done. So we may assume that $L = L_1$. Then $G[X_1]$ and $G[X_3]$ are K_3 -free (by Lemma 4.17:(i)). Next we claim the following:

4.22.1 *If X_1 is not anticomplete to Y_2 , then $G[X_2]$ is K_3 -free. Likewise, if X_3 is not anticomplete to Y_2 , then $G[X_2]$ is K_3 -free.*

Proof of 4.22.1. Suppose to the contrary that there is a component, say Q , that contains a K_3 induced by the vertices, say $\{p_1, p_2, p_3\}$. Since G is K_5 -free, we may assume that $p_1 z^* \notin E(G)$.

By our assumption, there are vertices, say $x \in X_1$ and $y \in Y_2$. Then since one of $\{x, y, v_3, v_2, p_1\}$ or $\{x, y, p_1, v_2, z^*\}$ does not induce a P_5 , we have $p_1x \in E(G)$. Then $\{p_1, p_2, p_3, x, v_2\}$ induces a $K_5 - e$ (by Lemma 4.1:(iii)), a contradiction. So 4.22.1 holds. ■

Now if $X_1 \cup X_3$ is not anticomplete to Y_2 , then from 4.22.1, $G[X_2]$ is K_3 -free, and so from Lemma 4.19, we have $\chi(G[X_1 \cup X_2 \cup L \cup \{v_3\}]) \leq 4$, and hence $\chi(G) \leq \chi(G[N(v_3)]) + \chi(G[X_1 \cup X_2 \cup L \cup \{v_3\}]) \leq 7$. So we may assume that $X_1 \cup X_3$ is anticomplete to Y_2 . Then since $\chi(G[Y_2 \cup \{v_2\}]) \leq 2$ (by Lemma 4.18:(ii)), from Lemma 4.19, it follows that $\chi(G[X_1 \cup Y_2 \cup X_3 \cup \{v_2, z^*\}]) \leq 4$. Since $N(v_2) \setminus \{z^*\} = X_2 \cup \{v_1, v_3\}$ (by Lemma 4.18:(i)), we see that $N(v_2) \setminus \{z^*\}$ is anticomplete to L . So from Lemma 4.18:(iii), it follows that $\chi(G[(N(v_2) \setminus \{z^*\}) \cup L]) \leq 3$. Hence $\chi(G) \leq 7$. This proves Lemma 4.22. □

Lemma 4.23 *If G contains an HVN, then $\chi(G) \leq 7$.*

Proof. We may assume that G contains an HVN, say K , with vertex-set $\{v_1, v_2, v_3, z^*, y_1\}$ such that $\{v_1, v_2, v_3, z^*\}$ induces a K_4 and $N_K(y_1) = \{v_2, v_3\}$. Let $C := \{v_1, v_2, v_3\}$. Then, with respect to C , we define the sets X, Y, Z and L as in Section 4.3, and we use the lemmas in Section 4.3. We also use Lemmas 4.17 to 4.20. Clearly $y_1 \in Y_1$ so that Y_1 is non-empty. We may assume that, from Lemma 4.21 and Lemma 4.22, G is (F_4, F_5) -free. Now for any $y \in Y_2 \cup Y_3$, since $\{v_1, v_2, v_3, z^*, y_1, y\}$ does not induce an F_4 , we have $Y_2 \cup Y_3 = \emptyset$. Also for any $x \in X_2 \cup X_3$, since $\{v_1, v_2, v_3, z^*, y_1, x\}$ does not induce an F_4 or an F_5 , we have $X_2 \cup X_3 = \emptyset$. Further since $\{v_2, v_3, z^*\}$ is not a clique cut-set separating $\{v_1\}$ and the rest of the vertices, we have $X_1 \neq \emptyset$. Next we claim that:

4.23.1 $\chi(G[X_1 \cup Y_1 \cup \{z^*\}]) \leq 4$.

Proof of 4.23.1. First suppose that there is a vertex, say $x \in X_1$ such that $xz^* \in E(G)$. Then for any $x' \in X_1 \setminus \{x\}$, since $\{v_1, v_2, v_3, x, z^*, x'\}$ does not induce an F_5 , we see that X_1 is complete to $\{z^*\}$. Since X_1 is complete to $\{v_1, z^*\}$ and since G is $(K_5, K_5 - e)$ -free, $G[X_1]$ is (P_3, K_3) -free; so $\chi(G[X_1]) \leq 2$. Then from Lemma 4.18:(ii), $\chi(G[X_1 \cup Y_1 \cup \{z^*\}]) \leq 4$ (by Lemma 4.1:(ii)), and we are done. So we may assume that X_1 is anticomplete to $\{z^*\}$. By Lemma 4.18:(ii), we pick a maximum stable set from each big-component of $G[Y_2]$, and let D be the union of these sets. To proceed further, we let $X'_1 := \{x \in X_1 \mid N(x) \cap D \neq \emptyset\}$, and consider a component of $G[X'_1]$, say Q . By Lemma 4.3:(iv), there are adjacent vertices, say $a, b \in Y_1$ such that $\{a, b\}$ is complete to $V(Q)$. Then since G is $(K_5, K_5 - e)$ -free, Q is (P_3, K_3) -free, and so $\chi(Q) \leq 2$. Hence $\chi(G[X'_1 \cup D]) \leq 3$. Since $G[X_1 \setminus X'_1]$ is complete to $\{v_1\}$, $G[X_1 \setminus X'_1]$ is $(K_4 - e)$ -free and hence $\chi(G[X_1 \setminus X'_1]) \leq 3$ (by Theorem I). Since $Y_1 \setminus D$ is a stable set and since $X_1 \setminus X'_1$ is anticomplete to $X'_1 \cup D$ (by Lemma 4.3:(iv)), we conclude that $\chi(G[X_1 \cup Y_1 \cup \{z^*\}]) \leq \chi(G[(X'_1 \cup D) \cup (X_1 \setminus X'_1)]) + \chi(G[(Y_1 \setminus D) \cup \{z^*\}]) \leq 3 + 1 = 4$ (by Lemma 4.1:(ii)). This proves 4.23.1. ■

From 4.23.1, and from Lemma 4.18:(i) and Lemma 4.18:(iii), we have $\chi(G) \leq \chi(G[C \cup L]) + \chi(G[X_1 \cup Y_1 \cup \{z^*\}]) \leq 3 + 4 = 7$. This proves Lemma 4.23. □

Now we prove the main theorem of this subsection, and is given below.

Theorem 4.24 *Let G be a $(P_5, K_5 - e, F_1)$ -free graphs with $\omega(G) = 4$. Then either G is the complement of a bipartite graph or G has a clique cut-set or $\chi(G) \leq 7$.*

Proof. Let G be a connected $(P_5, K_5 - e, F_1)$ -free graph with $\omega(G) = 4$. We may assume that G has no clique cut-set and that G is not the complement of a bipartite graph. By Theorem 4.4, we may assume that G contains an HVN. Now the theorem follows from Lemma 4.23. \square

4.6 Chromatic bound for $(P_5, K_5 - e)$ -free graphs

In this section, we state and prove our main results.

Theorem 4.25 *Let G be a connected $(P_5, K_5 - e)$ -free graph. Then the following hold:*

- (a) *If $\omega(G) \geq 5$, then either G is the complement of a bipartite graph or G has a clique cut-set or $\chi(G) \leq 6$.*
- (b) *If $\omega(G) = 4$, then either G is the complement of a bipartite graph or G has a clique cut-set or $\chi(G) \leq 7$.*

Proof. Let G be a connected $(P_5, K_5 - e)$ -free graph with $\omega(G) \geq 4$. If G contains one of F_1, F_2 or F_3 , then the theorem follows from Theorems 4.8, 4.12 and 4.15. So we may assume that G is (F_1, F_2, F_3) -free. Now if $\omega(G) \geq 5$, then the theorem follows from Theorem 4.16, and if $\omega(G) = 4$, then the theorem follows from Theorem 4.24. This completes the proof of Theorem 4.25. \square

As a corollary of Theorem 4.25, we strengthen Theorem H. Note that any clique expansion of a C_5 is an imperfect $(3K_1, K_5 - e)$ -free graph which has no clique cut-set (see the graph G_1 for example in Figure 17), and we refer to the graph G_2 (see Figure 17) for another non-trivial example.

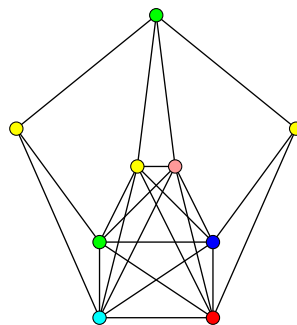

Figure 18: The graph H^* .

Corollary 1 *If G is a connected $(P_5, K_5 - e)$ -free graph with $\omega(G) \geq 7$, then either G is the complement of a bipartite graph or G has a clique cut-set. Moreover, the assumption on the lower bound of ω is tight. That is, there is a connected $(P_5, K_5 - e)$ -free imperfect graph H with $\omega(H) = 6$ and has no clique cut-set.*

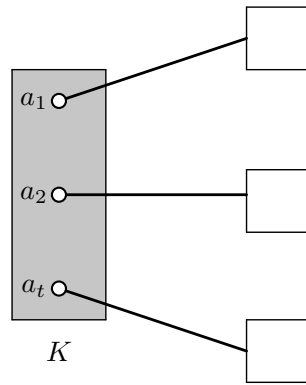

Figure 19: Schematic representation of a $(P_5, K_5 - e)$ -free graph G with $\chi(G) = \omega(G) = t$. (Here a shaded rectangle represents a non-empty clique of size t . Each square represents disjoint union of cliques with size at most $t - 1$ (possibly empty). A thick line between a vertex and a square represents that the vertex is adjacent to all the vertices of the square.)

Proof. The first assertion is an immediate consequence of Theorem 4.25. For the second assertion, consider the graph H^* given in Figure 18. Then H^* is a connected $(P_5, K_5 - e)$ -free imperfect graph with $\omega(H^*) = 6$ and has no clique cut-set. \square

Further, we have the following theorem.

Theorem 4.26 *If G is a $(P_5, K_5 - e)$ -free graph with $\omega(G) \geq 4$, then $\chi(G) \leq \max\{7, \omega(G)\}$. Moreover, the bound is tight when $\omega(G) \notin \{4, 5, 6\}$.*

Proof. Let G be a $(P_5, K_5 - e)$ -free graph with $\omega(G) \geq 4$. We prove the first assertion by induction on $|V(G)|$. We may assume that G is connected and is imperfect. Then from Theorem 4.25, either G has a clique cut-set or $\chi(G) \leq 7$. If $\chi(G) \leq 7$, then we are done. So we may assume that G has a clique cut-set, say K . Let A and B be a partition of $V(G) \setminus K$ such that $A, B \neq \emptyset$ and A is anticomplete to B . Then $\chi(G) = \max\{\chi(G[K \cup A]), \chi(G[K \cup B])\}$, and hence by induction hypothesis, we have $\chi(G) \leq \max\{\max\{7, \omega(G[K \cup A])\}, \max\{7, \omega(G[K \cup B])\}\} \leq \max\{7, \omega(G)\}$. This proves the first assertion. To prove the second assertion, consider the graph G (see Figure 19) that consists of a complete graph K_t where $t \geq 7$, say Q , such that

- (a) Each component of $G[V(G) \setminus V(Q)]$ is a complete graph with vertex-set of size at most $t - 1$; $\omega(G) = \omega(Q) = t$.
- (b) For each component K in $G[V(G) \setminus V(Q)]$, there is a unique $v \in V(Q)$ such that $\{v\}$ is complete to $V(K)$.
- (c) no other edges in G .

Clearly G is a $(P_5, K_5 - e)$ -free perfect graph, and so $\chi(G) = \omega(G) = t$. This proves Theorem 4.26. \square

Next we have the following corollary that partially answers Problem 3. That is, every $(P_5, K_5 - e)$ -free graph is near optimal colorable.

Corollary 2 *If G is a $(P_5, K_5 - e)$ -free graph, then $\chi(G) \leq \max\{7, \omega(G)\}$.*

Proof. Let G be a $(P_5, K_5 - e)$ -free graph. If $\omega(G) \leq 3$, then G is (P_5, K_4) -free, and hence $\chi(G) \leq 5$ [63]. So we may assume that $\omega(G) \geq 4$. Now the corollary follows from Theorem 4.26. \square

4.7 Concluding remarks

In this chapter, we studied the near optimal colorability of $(P_5, K_5 - e)$ -free graphs via structure theorems using some intermediate results which rely on certain special graphs. In particular, we showed that every $(P_5, K_5 - e)$ -free graph G satisfies $\chi(G) \leq \max\{7, \omega(G)\}$.

While the bound given in Theorem 4.26 is tight for $\omega(G) \geq 7$, the bound does not seem to be tight for $\omega(G) \notin \{4, 5, 6\}$. In this regard, we have following.

- The graph G_2 is an imperfect $(P_5, K_5 - e)$ -free graph which has no clique cut-set and contains an F_1 . Also $\chi(G_2) \leq 5$ (see Figure 17 for a 5-coloring). It is easy to check that $\alpha(G_2) = 2$, and hence $\chi(G_2) \geq \left\lceil \frac{|V(G_2)|}{\alpha(G_2)} \right\rceil = 5$. Thus the bound given in Theorem 4.8 is tight.
- The bound given in Theorem 4.25:(b) does not seem to be tight when $\omega = 4$. But there are $(P_5, K_5 - e)$ -free graphs with $\omega = 4$ and $\chi = 5$. For instance, consider the graphs G_1 and G_2 given in Figure 17. We have seen that $\chi(G_2) = 5$, and similarly we have $\chi(G_1) = 5$. Also it is easy check that $\omega(G_1) = \omega(G_2) = 4$.

Since k -COLORING for the class of P_5 -free graphs can be solved in polynomial time for every fixed positive integer $k \leq 6$ [86], we conclude that CHROMATIC NUMBER for the class of $(P_5, K_5 - e)$ -free graphs can be solved in polynomial time (see Section 4.1). We remark that this conclusion may also be obtained from Theorem 4.25 by using clique separator decomposition techniques (see [132]) and a result of Hoàng, Kamiński, Lozin, Sawada and Shu [86].

Chapter 5

Coloring (P_5, flag) -free graphs

5.1 Introduction

In this chapter¹, we are interested in finding the tight chromatic bound for the class of (P_5, flag) -free graphs. Here, a flag is the graph obtained from a K_4 by attaching a pendant vertex (see Figure 2). Thus, the class of flag-free graphs generalizes the class of K_4 -free graphs. Recall that, from a result of Esperet, Lemoine, Maffray and Morel [63], every (P_5, K_4) -free graph is 5-colorable. Hence every (P_5, flag) -free graph G with $\omega(G) \leq 3$ satisfies $\chi(G) \leq 5$. In this chapter, we show that every (P_5, flag) -free graph G with $\omega(G) \geq 4$ satisfies $\chi(G) \leq \max\{8, 2\omega(G) - 3\}$, and that the bound is tight for $\omega(G) \in \{4, 5, 6\}$. In particular, we show that every (P_5, flag, K_5) -free graph that contains a K_4 satisfies $\chi(G) \leq 8$ and that the bound is tight. We note that our results improve the earlier mentioned results of Dong, Xu and Xu [55, 56].

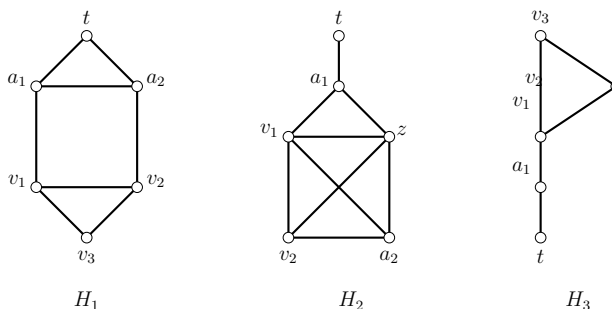

Figure 20: Labelled graphs IV: Some special graphs.

We will use the following theorem to prove our results.

Theorem J ([91]) *Every $(P_5, K_1 + K_3)$ -free graph G with $\omega(G) \geq 5$ satisfies $\chi(G) \leq 2\omega(G) - 3$.*

We will prove our result based on a sequence of partial results which depend on some special graphs; see Figure 20. We begin by proving some structural properties of (P_5, flag) -free graphs that contain a K_3 .

¹The results of this chapter are appearing in “A. Char and T. Karthick. *Improved bounds on the chromatic number of (P_5, flag) -free graphs*. *Discrete Mathematics* (346) 2023. Article no.: 113501. <https://doi.org/10.1016/j.disc.2023.113501>”

5.2 Structural properties of (P_5, flag) -free graphs that contain a K_3

In this section, we prove some structural properties of (P_5, flag) -free graphs that contain a K_3 , and use them often in the latter sections.

Let G be a connected (P_5, flag) -free graph. Suppose that G contains a K_3 with vertex-set, say $C := \{v_1, v_2, v_3\}$. For $i \in \{1, 2, 3\}$, $i \bmod 3$, we let:

$$\begin{aligned} A_i &:= \{v \in V(G) \setminus C \mid N(v) \cap C = \{v_i\}\}, \\ B_i &:= \{v \in V(G) \setminus C \mid N(v) \cap C = C \setminus \{v_i\}\}, \\ Z &:= \{v \in V(G) \setminus C \mid N(v) \cap C = C\}, \text{ and} \\ T &:= \{v \in V(G) \setminus C \mid N(v) \cap C = \emptyset\}. \end{aligned}$$

Clearly $V(G) = C \cup A \cup B \cup Z \cup T$. Throughout this section, we assume that the arithmetic operations on the indices are in modulo 3. Next we give some relations between the subsets of $V(G)$ in the following lemmas.

Lemma 5.1 *The following statements hold:*

- (i) $G[A_i \cup B_{i+1}]$ is K_3 -free. Likewise, $G[A_i \cup B_{i-1}]$ is K_3 -free.
- (ii) A is complete to Z .
- (iii) T is anticomplete to Z .
- (iv) For any $a \in A_i$ and $k \in \{i+1, i-1\}$, $B_k \setminus N(a)$ is a stable set.
- (v) The vertex-set of each component of $G[T]$ is a homogeneous set. Moreover, $G[T]$ is K_3 -free.
- (vi) The vertex-set of each component of B_i is a homogeneous set in $G[A_i \cup B_i \cup T]$.

Proof. (i): We will show for $i = 1$. If there are vertices, say p, q and r in $A_1 \cup B_2$ such that $\{p, q, r\}$ induces a K_3 , then $\{p, q, r, v_2, v_1\}$ induces a flag, a contradiction. So Lemma 5.1:(i) holds. ■

(ii): If there are non-adjacent vertices, say $a \in A_1$ and $z \in Z$, then $\{v_2, v_3, z, a, v_1\}$ induces a flag, a contradiction. So Lemma 5.1:(ii) holds. ■

(iii): If there are adjacent vertices, say $t \in T$ and $z \in Z$, then $\{v_1, v_2, v_3, t, z\}$ induces a flag, a contradiction. So Lemma 5.1:(iii) holds. ■

(iv): If there are adjacent vertices in $B_k \setminus N(a)$, say b and b' , then $\{b, b', v_k, a, v_i\}$ induces a flag, a contradiction. So Lemma 5.1:(iv) holds. ■

(v): Suppose not. Then there are vertices, say $x, y \in T$ and $a \in V(G) \setminus T$ such that $ax, xy \in E(G)$ and $ay \notin E(G)$. Since G is connected, by Lemma 5.1:(iii) and up to symmetry, we may assume that $a \in A_1 \cup B_2$. Then $\{v_2, v_1, a, x, y\}$ induces a P_5 , a contradiction. Thus the vertex-set of each component of $G[T]$ is a homogeneous set. This proves the first assertion of Lemma 5.1:(v).

To prove the second assertion of Lemma 5.1:(v), suppose to the contrary that there are vertices, say $p, q, r \in T$ such that $\{p, q, r\}$ induces a K_3 . Since G is connected, and by Lemma 5.1:(iii), we may assume up to symmetry that there is a vertex, say $s \in A_1 \cup B_2$ such that $\{s\}$ is not

anticomplete to $\{p, q, r\}$. Then by the first assertion, $\{p, q, r, v_1, s\}$ induces a flag, a contradiction. So, $G[T]$ is K_3 -free. This proves Lemma 5.1:(v). ■

(vi): We will show for $i = 1$. If there are vertices, say $x, y \in B_1$ and $a \in A_1 \cup T$ such that $ax, xy \in E(G)$ and $ay \notin E(G)$, then $\{v_2, v_3, y, a, x\}$ induce a flag, a contradiction. So Lemma 5.1:(vi) holds. □

Lemma 5.2 *Suppose that there is a vertex, say $t \in T$ which has a neighbor in A_i , say a_i , where $i \in \{1, 2, 3\}$. Then the following hold:*

(i) Z is a stable set.

(ii) B_{i+1} and B_{i-1} are stable sets.

(iii) $\{t\}$ is complete to $A_{i+1} \cup A_{i-1}$.

(iv) A_i is complete to $A_{i+1} \cup A_{i-1}$.

(v) If G is H_1 -free, then $A_{i+1} \cup A_{i-1} = \emptyset$. (See Figure 20 for the graph H_1 .)

(vi) If $A_{i+1} \cup A_{i-1} \neq \emptyset$, then A_i is a stable set.

Proof. We will show the lemma for $i = 1$. By our assumption, there are adjacent vertices, say $a_1 \in A_1$ and $t \in T$.

(i): If there are adjacent vertices, say $z_1, z_2 \in Z$, then, by Lemma 5.1:(ii), $\{v_1, z_1, z_2, t, a_1\}$ induces a flag, a contradiction. So Lemma 5.2:(i) holds. ■

(ii): We will show that B_2 is a stable set. Suppose to the contrary that there are adjacent vertices, say b and b' in B_2 . By Lemma 5.1:(iv), we may assume that $a_1b \in E(G)$, and so by Lemma 5.1:(i), $a_1b' \notin E(G)$. Then since $\{t, a_1, b, v_3, v_2\}$ does not induce a P_5 , we have $bt \in E(G)$, and since $\{b', v_1, v_3, t, b\}$ does not induce a flag, we have $b't \in E(G)$. But then $\{a_1, t, b', v_3, v_2\}$ induces a P_5 , a contradiction. So B_2 is a stable set. This proves Lemma 5.2:(ii). ■

(iii): Suppose not. Then there is a vertex, say $p \in A_2 \cup A_3$ such that $pt \notin E(G)$. We may assume that $p \in A_2$. Then since $\{t, a_1, v_1, v_2, p\}$ does not induce a P_5 , we have $a_1p \in E(G)$, and then $\{t, a_1, p, v_2, v_3\}$ induces a P_5 , a contradiction. So $\{t\}$ is complete to A_2 . Likewise, $\{t\}$ is complete to A_3 . This proves Lemma 5.2:(iii). ■

(iv): If there are non-adjacent vertices, say $a \in A_1$ and $a' \in A_2 \cup A_3$, then, by Lemma 5.2:(iii), $a't \in E(G)$, and again by Lemma 5.2:(iii), $at \in E(G)$, and then $\{a, t, a', v_2, v_3\}$ induces a P_5 , a contradiction. So Lemma 5.2:(iv) holds. ■

(v): Suppose to the contrary that there is a vertex, say $a' \in A_2 \cup A_3$. We may assume, up to symmetry, that $a' \in A_2$. Then, by Lemma 5.2:(iii), $a't \in E(G)$, and by Lemma 5.2:(iv), $a_1a' \in E(G)$. Then $\{v_1, v_2, v_3, a_1, a', t\}$ induces a H_1 , a contradiction. So Lemma 5.2:(v) holds. ■

(vi): Suppose to the contrary that there are adjacent vertices, say a and a' in A_1 . Let $p \in A_2 \cup A_3$. We may assume, up to symmetry, that $p \in A_2$. Then, by Lemma 5.2:(iii), $pt \in E(G)$, and again by Lemma 5.2:(iii), $at, a't \in E(G)$. Then by Lemma 5.2:(iv) $\{a, a', t, v_2, p\}$ induces a flag, a contradiction. So Lemma 5.2:(vi) holds. □

5.3 (P_5, flag) -free graphs that contain some special graphs

In this section, we prove that if G is a (P_5, flag) -free graph that contains one of H_1 , H_2 or H_3 then G is 8-colorable.

5.3.1 (P_5, flag) -free graphs that contain an H_1

Theorem 5.3 *If G is a connected (P_5, flag) -free graph that contains an H_1 , then G is 8-colorable.*

Proof. Let G be a connected (P_5, flag) -free graph. Suppose that G contains an H_1 with vertices and edges as shown in Figure 20. Let $C := \{v_1, v_2, v_3\}$. Then with respect to C , we define the sets A , B , T and Z as in Section 5.2, and we use the lemmas in Section 5.2. Since $a_1 \in A_1$, $a_2 \in A_2$, and $t \in T$, we have A_1 , A_2 and T are non-empty. Note that A_1 and A_2 are not anticomplete to T . So, by Lemma 5.2:(i), Z is a stable set, and by Lemma 5.2:(ii), B_1 , B_2 and B_3 are stable sets. Also, by Lemma 5.2:(vi), A_1 , A_2 and A_3 are stable sets. Then we claim the following:

5.3.1 A_3 is empty.

Proof of 5.3.1. Suppose not, and let $a_3 \in A_3$. Then by Lemma 5.2:(iii), $a_3t \in E(G)$, and by Lemma 5.2:(iv), $a_1a_3, a_2a_3 \in E(G)$. But then $\{a_2, a_3, t, v_1, a_1\}$ induces a flag, a contradiction. So 5.3.1 holds. ■

Now, we let $D_1 := A_1$, $D_2 := A_2$, $D_3 := B_1 \cup \{v_1\}$, $D_4 := B_2 \cup \{v_2\}$ and $D_5 := B_3 \cup \{v_3\}$. Then D_1, D_2, \dots, D_5 are stable sets, and $V(G) \setminus (T \cup Z) = \bigcup_{j=1}^5 D_j$; so $\chi(G - (T \cup Z)) \leq 5$. Moreover, by Lemma 5.1:(v), Lemma 5.1:(iii) and Theorem A, $G[T \cup Z]$ is 3-colorable. So $\chi(G) \leq 8$ and G is 8-colorable. □

5.3.2 (P_5, flag) -free graphs that contain an H_2

Theorem 5.4 *If G is a connected (P_5, flag) -free graph that contains an H_2 , then G is 8-colorable.*

Proof. Let G be a connected (P_5, flag) -free graph. By Theorem 5.3, we may assume that G is H_1 -free. Suppose that G contains an H_2 with vertices and edges as shown in Figure 20. Let $C := \{v_1, v_2, v_3\}$. Then with respect to C , we define the sets A , B , T and Z as in Section 5.2, we use the lemmas in Section 5.2. Since $a_1 \in A_1$, $t \in T$ and $z \in Z$, we have A_1 , T and Z are non-empty, and that A_1 is not anticomplete to T . Then, by Lemma 5.2:(i), Z is a stable set, and since G is H_1 -free, by Lemma 5.2:(v), $A_2 \cup A_3 = \emptyset$.

First suppose that $B_1 = \emptyset$. Then $V(G) = \{v_1\} \cup N(v_1) \cup T$. Since G is K_5 -free, $G[N(v_1)]$ is (P_5, K_4) -free, and so by Theorem B, $G[N(v_1)]$ is 5-colorable. Also, by Lemma 5.1:(v), $G[T]$ is K_3 -free, and thus, by Theorem A, $G[T \cup \{v_1\}]$ is 3-colorable. Hence G is 8-colorable. So we may assume that $B_1 \neq \emptyset$. Next, we claim the following:

5.4.1 *The vertex-set of each component of $G[A_1]$ is a homogeneous set in $G[A_1 \cup B_1 \cup T]$.*

Proof of 5.4.1. Suppose not. Then there are vertices, say $x, y \in A_1$ and $b \in B_1 \cup T$ such that $bx, xy \in E(G)$ and $by \notin E(G)$. Since, by Lemma 5.1:(ii), $\{v_1, y, z, b, x\}$ does not induce a flag, we have $bz \in E(G)$. Hence, by Lemma 5.1:(iii), $b \in B_1$. Then, by Lemma 5.1:(ii), $\{b, v_2, v_3, y, z\}$ induces a flag, a contradiction. So 5.4.1 holds. ■

5.4.2 *If $a \in A_1$ and $b \in B_1$ are non-adjacent vertices, then $N(a) \cap T = N(b) \cap T$.*

Proof of 5.4.2. Since for any $t' \in N(a) \cap T$, $\{t', a, v_1, v_2, b\}$ does not induce a P_5 , we have $N(a) \cap T \subseteq N(b) \cap T$. Also, since for any $t' \in N(b) \cap T$, $\{a, v_1, v_2, b, t'\}$ does not induce a P_5 , we have $N(b) \cap T \subseteq N(a) \cap T$. So $N(a) \cap T = N(b) \cap T$. This proves 5.4.2. ■

5.4.3 *For every pair of vertices $u, v \in A_1$, we have either $N(u) \cap T \subseteq N(v) \cap T$ or $N(v) \cap T \subseteq N(u) \cap T$.*

Proof of 5.4.3. Suppose not, and let t_1 and $t_2 \in T$ be such that $ut_1, vt_2 \in E(G)$ and $ut_2, vt_1 \notin E(G)$. By 5.4.1, we have $uv \notin E(G)$, and by Lemma 5.1:(v), we have $t_1 t_2 \notin E(G)$. Then $\{t_1, u, v_1, v, t_2\}$ induces a P_5 , a contradiction. So 5.4.3 holds. ■

5.4.4 *For every pair of vertices $u, v \in A_1$, we have either $N(u) \cap B_1 \subseteq N(v) \cap B_1$ or $N(v) \cap B_1 \subseteq N(u) \cap B_1$.*

Proof of 5.4.4. Suppose not, and let $b, b' \in B_1$ be such that $ub, vb' \in E(G)$ and $ub', vb \notin E(G)$. By 5.4.1, $uv \notin E(G)$ and by Lemma 5.1:(vi), we have $bb' \notin E(G)$. Then $\{b, u, v_1, v, b'\}$ induces a P_5 , a contradiction. So 5.4.4 holds. ■

Now, we let $M := \{a \in A_1 \mid N(a) \cap T \neq \emptyset\}$. Clearly $a_1 \in M$, and so $M \neq \emptyset$. By 5.4.3, we let $M_1 := \{a \in M \mid \text{for each } a' \in M \text{ with } a \neq a', \text{ we have } N(a') \cap T \subseteq N(a) \cap T\}$. By 5.4.4, we let a^* be the vertex in M_1 such that for all $a \in M_1$ with $a \neq a^*$, we have $N(a) \cap B_1 \subseteq N(a^*) \cap B_1$.

By Lemma 5.1:(vi), if Q is the vertex-set of a component of B_1 , then Q is either complete to $\{a^*\}$ or anticomplete to $\{a^*\}$. Let D_1 be the set of vertices of big components of $G[B_1]$ which are complete to $\{a^*\}$, and let D_2 be the set of vertices of big components of $G[B_1]$ which are anticomplete to $\{a^*\}$. Then we claim the following:

5.4.5 *D_1 is anticomplete to $N(a^*) \cap T$.*

Proof of 5.4.5. Suppose not, and let $d \in D_1$ and $t' \in N(a^*) \cap T$ be adjacent. By the definition of D_1 , there is a vertex, say $d' \in B_1$ such that $dd' \in E(G)$. By Lemma 5.1:(vi), $d't', d'a^* \in E(G)$. Now, $\{d, d', t', v_1, a^*\}$ induces a flag, a contradiction. So 5.4.5 holds. ■

5.4.6 *D_2 is anticomplete to M .*

Proof of 5.4.6. Suppose not, and let $d \in D_2$ and $m \in M$ be adjacent. By the definition of D_2 , there is a vertex, say $d' \in B_1$ such that $dd' \in E(G)$. By the definition of M , there is a vertex, say t' such that $mt' \in E(G)$. By the choice of a^* , $t'a^* \in E(G)$ and hence by 5.4.2, $dt' \in E(G)$. So, by

Lemma 5.1:(vi), $d't', d'm \in E(G)$. Then, by 5.4.1, $\{d, d', t', v_1, m\}$ induces a flag, a contradiction. So 5.4.6 holds. ■

5.4.7 D_2 is anticomplete to Z .

Proof of 5.4.7. Suppose not, and let $d \in D_2$ and $z' \in Z$ be adjacent. Then, by Lemma 5.1:(ii) and Lemma 5.1:(iii), $\{d, v_2, v_3, a^*, z'\}$ induces a flag, a contradiction. So 5.4.7 holds. ■

By Theorem A and Lemma 5.1:(i), there are three stable sets, say S_{11}, S_{12} and S_{13} such that $D_2 = S_{11} \cup S_{12} \cup S_{13}$. Also, by Theorem A and Lemma 5.1:(v), there are three stable sets, say S_{21}, S_{22} and S_{23} such that $T \setminus N(a^*) = S_{21} \cup S_{22} \cup S_{23}$. Then since $S_{13} \subseteq D_2$, by 5.4.7, $S_{13} \cup Z$ is a stable set.

Now we split the proof into two subcases based on the adjacency relationship between $B_2 \cup B_3$ and T .

Case 3 $B_2 \cup B_3$ is anticomplete to T .

We now claim the following:

5.4.8 $B_2 \cup B_3$ is anticomplete to M .

Proof of 5.4.8. Suppose not, and let $b \in B_2 \cup B_3$ and $m \in M$ be adjacent. We may assume that $b \in B_2$. Let $t' \in T$ be a vertex such that $mt' \in E(G)$. Then, $\{t', m, b, v_3, v_2\}$ induces a P_5 , a contradiction. So 5.4.8 holds. ■

5.4.9 $G[(A_1 \setminus M) \cup B_2 \cup B_3 \cup \{v_2, v_3\}]$ is K_3 -free.

Proof of 5.4.9. Suppose not. Then there are vertices $p_1, p_2, p_3 \in (A_1 \setminus M) \cup B_2 \cup B_3 \cup \{v_2, v_3\}$ such that $\{p_1, p_2, p_3\}$ induces a K_3 . By Lemma 5.1:(i) and Lemma 5.2:(ii), $p_1 \in A_1 \setminus M$, $p_2 \in B_2$ and $p_3 \in B_3$. Then, by 5.4.1, $a^*p_1 \notin E(G)$, and so by 5.4.8, $\{p_1, p_2, p_3, a^*, v_1\}$ induces a flag which is a contradiction. So 5.4.9 holds. ■

Recall that, by Theorem A, (P_5, K_3) -free graphs are 3-colorable. Thus, the following hold:

- (i) By Lemma 5.1:(i), there are three stable sets, say S_{31}, S_{32} and S_{33} , such that $D_1 = S_{31} \cup S_{32} \cup S_{33}$.
- (ii) By Lemma 5.1:(v), there are three stable sets, say S_{41}, S_{42} and S_{43} , such that $N(a^*) \cap T = S_{41} \cup S_{42} \cup S_{43}$.
- (iii) By Lemma 5.1:(i), there are three stable sets, say S_{51}, S_{52} and S_{53} , such that $M = S_{51} \cup S_{52} \cup S_{53}$.
- (iv) By 5.4.9, there are three stable sets, say S_{61}, S_{62} and S_{63} , such that $(A_1 \setminus M) \cup B_2 \cup B_3 \cup \{v_2, v_3\} = S_{61} \cup S_{62} \cup S_{63}$.

Now we define $W_1 := S_{21} \cup S_{51} \cup S_{61}$, $W_2 := S_{22} \cup S_{52} \cup S_{62}$, $W_3 := S_{11} \cup S_{23} \cup S_{53}$, $W_4 := S_{41} \cup S_{63}$, $W_5 := S_{31} \cup S_{42} \cup \{v_1\}$, $W_6 := S_{32} \cup S_{43}$, $W_7 := S_{33} \cup S_{12} \cup (B_1 \setminus (D_1 \cup D_2))$ and $W_8 := S_{13} \cup Z$. Then $V(G) = \bigcup_{j=1}^8 W_j$. Moreover, we have the following:

5.4.10 W_1 is a stable set. Likewise, W_2 is a stable set.

Proof of 5.4.10. Suppose not, and let $p, q \in W_1$ be adjacent. First suppose that $p \in S_{21} \subseteq T \setminus N(a^*)$. Since T is anticomplete to $(A_1 \setminus M) \cup B_2 \cup B_3 \cup \{v_2, v_3\}$, we have $q \in S_{51}$. Then, by the choice of a^* , $N(q) \subseteq N(a^*)$, and so $pa^* \in E(G)$, a contradiction. So we may assume that $p \in S_{51} \subseteq M$ and $q \in S_{61}$. Since by 5.4.8, M is anticomplete to $B_2 \cup B_3 \cup \{v_2, v_3\}$, $q \in A_1 \setminus M$. By the definition of M , there is a vertex, say $t' \in T$ such that $pt' \in E(G)$. Then, by 5.4.1, $qt' \in E(G)$ and hence $q \in M$, a contradiction. So W_1 is a stable set. This proves 5.4.10. ■

5.4.11 W_3 is a stable set.

Proof of 5.4.11. Suppose not, and let $p, q \in W_3$ be adjacent vertices. If $p \in S_{11} \subseteq D_2$, then, since $\{a^*\}$ is anticomplete to $S_{23} \subseteq T \setminus N(a^*)$, by 5.4.2, we have $q \notin S_{23}$, and hence $q \in S_{53} \subseteq M$ which is a contradiction to 5.4.6; so we may assume that $p \in S_{23}$ and $q \in S_{53}$. Then, since $N(q) \cap T \subseteq N(a^*) \cap T$, we have $pa^* \in E(G)$, a contradiction. So 5.4.11 holds. ■

5.4.12 W_4 is a stable set.

Proof of 5.4.12. Recall that $S_{41} \subseteq T$ and $S_{63} \subseteq (A_1 \setminus M) \cup B_2 \cup B_3 \cup \{v_2, v_3\}$. Now, by our assumption that T is anticomplete to $B_2 \cup B_3$, and by the definitions of M and T , we see that W_4 is a stable set. This proves 5.4.12. ■

5.4.13 W_5, W_6 and W_7 are stable sets.

Proof of 5.4.13. This follows from 5.4.5, and by the definitions of D_1 and D_2 . ■

Recall that W_8 is a stable set. So, by 5.4.10, 5.4.11, 5.4.12 and 5.4.13, we conclude that G is 8-colorable, and this completes the proof in Case 1.

Case 4 $B_2 \cup B_3$ is not anticomplete to T .

Let $b \in B_2 \cup B_3$ and $t' \in T$ be such that $bt' \in E(G)$. We may assume that $b \in B_2$. Now we claim the following:

5.4.14 If $t_1 \in T$ has a neighbor in $B_2 \cup B_3$, then $\{t_1\}$ is complete to A_1 .

Proof of 5.4.14. Suppose not, and let a be a vertex A_1 be such that $at_1 \notin E(G)$. Let b' be a vertex in $B_2 \cup B_3$ which is a neighbor of t_1 . We may assume that $b' \in B_2$. Since by Lemma 5.1:(iii), $\{z, v_1, v_3, t_1, b'\}$ does not induce a flag, we have $b'z \notin E(G)$. So, by Lemma 5.1:(ii) and Lemma 5.1:(iii), if $ab' \in E(G)$, then $\{v_2, z, a, b', t_1\}$ induces a P_5 , a contradiction, and if $ab' \notin E(G)$, then $\{a, z, v_3, b', t_1\}$ induces a P_5 , a contradiction. So $\{t_1\}$ is complete to A_1 . This proves 5.4.14. ■

5.4.15 A_1 is a stable set.

Proof of 5.4.15. Suppose not, and let $p, q \in A_1$ be such that $pq \in E(G)$. Then, by Lemma 5.1:(i), we may assume that $bp \notin E(G)$. Then, by 5.4.14, $\{p, t', b, v_3, v_2\}$ induces a P_5 , a contradiction. So 5.4.15 holds. ■

By 5.4.14, we have $M = A_1$. By Lemma 5.2:(ii), B_2 and B_3 are stable sets. Moreover, we have the following:

5.4.16 $A_1 \cup S_{11} \cup S_{21}$ is a stable set.

Proof of 5.4.16. Suppose not, let $p, q \in A_1 \cup S_{11} \cup S_{21}$ be adjacent. First suppose that $p \in A_1$. Since $A_1 = M$ and $S_{11} \subseteq D_2$, by 5.4.6, we have $q \in S_{21}$. By the definition of a^* , $N(p) \cap T \subseteq N(a^*) \cap T$. So $q \in N(a^*) \cap T$, a contradiction. So we may assume that $p \in S_{11}$ and $q \in S_{21}$. Then since $pa^* \notin E(G)$ and $qa^* \notin E(G)$, by 5.4.2, $pq \notin E(G)$, a contradiction. So 5.4.16 holds. ■

5.4.17 $B_2 \cup S_{22} \cup \{v_2\}$ is a stable set. Likewise, $B_3 \cup S_{23} \cup \{v_3\}$ is a stable set.

Proof of 5.4.17. Suppose not, and let $p, q \in B_2 \cup S_{22} \cup \{v_2\}$ be adjacent. We may assume that $p \in B_2$ and $q \in S_{22} \subseteq T \setminus N(a^*)$. Then, by 5.4.14, $qa^* \in E(G)$, a contradiction. So 5.4.17 holds. ■

5.4.18 $S_{12} \cup (B_1 \setminus (D_1 \cup D_2)) \cup \{v_1\}$ is a stable set.

Proof of 5.4.18. Since $S_{12} \subseteq D_2$, the proof follows from the definition of D_2 . ■

Since $S_{13} \cup Z$ is a stable set, by 5.4.16, 5.4.17 and 5.4.18, we conclude that $\chi(G[V(G) \setminus (D_1 \cup (N(a^*) \cap T))]) \leq 5$. By 5.4.5, D_1 is anticomplete to $N(a^*) \cap T$. So by Lemma 5.1:(i) and Lemma 5.1:(v), $D_1 \cup (N(a^*) \cap T)$ induces a K_3 -free graph. Hence, by Theorem A, $\chi(G[D_1 \cup (N(a^*) \cap T)]) \leq 3$. So we have $\chi(G) \leq 8$ and G is 8-colorable. □

5.3.3 (P_5, flag) -free graphs that contain an H_3

Theorem 5.5 *If G is a connected (P_5, flag) -free graph that contains an H_3 , then G is 8-colorable.*

Proof. Let G be a connected (P_5, flag) -free graph. Suppose that G contains an H_3 with vertices and edges as shown in Figure 20. Let $C := \{v_1, v_2, v_3\}$. Then, with respect to C , we define the sets A, B, T and Z as in Section 5.2, and we use the lemmas in Section 5.2. By Theorem 5.3 and Theorem 5.4, we may assume that G is (H_1, H_2) -free. Since $a_1 \in A_1$ and $t \in T$, clearly A_1 and T are non-empty. Also we have $Z = \emptyset$; otherwise, for any $z \in Z$, by Lemma 5.1:(ii) and Lemma 5.1:(iii), $\{v_1, v_2, v_3, a_1, t, z\}$ induces an H_2 , a contradiction. Since A_1 is not anticomplete to T , and since G is H_1 -free, by Lemma 5.2:(v), $A_2 \cup A_3 = \emptyset$. Since A_1 is not anticomplete to T , by Lemma 5.2:(ii), B_3 is a stable set. Now we claim the following:

5.5.1 B_1 is a stable set.

Proof of 5.5.1. Suppose not. Then there are adjacent vertices in B_1 , say b and b' . By Lemma 5.1:(vi), we have either $a_1b, a_1b' \in E(G)$ or $a_1b, a_1b' \notin E(G)$. If $a_1b, a_1b' \notin E(G)$, $\{b, b', v_2, v_1, v_3, a_1\}$ induces an H_2 , a contradiction. So we may assume that $a_1b, a_1b' \in E(G)$. Since, by Lemma 5.1:(vi), $\{b, b', t, v_1, a_1\}$ does not induce a flag, we have $bt, b't \notin E(G)$. Then $\{b, v_2, v_3, a_1, b', t\}$ induces an H_2 , a contradiction. So 5.5.1 holds. ■

Now, by Lemma 5.1:(i), Lemma 5.1:(v) and Theorem A, $\chi(G[A_1 \cup B_2]) \leq 3$ and $\chi(G[T]) \leq 3$. Moreover, since C is anticomplete to T , $\chi(G[C \cup T]) \leq 3$. So, by 5.5.1, $\chi(G) = \chi(G[C \cup A_1 \cup B_1 \cup B_2 \cup B_3 \cup T]) \leq 8$ and G is 8-colorable. □

5.4 (P_5, flag, K_5) -free graphs that contain a K_4

In this section, we will show that if G is a (P_5, flag, K_5) -free graph that contains a K_4 , then G is 8-colorable. Here we assume that all the arithmetic operations on the indices are in modulo 3 unless stated otherwise.

First we prove the case when our graph contains a dominating- K_4 .

Theorem 5.6 *If G is a connected (P_5, flag, K_5) -free graph that contains a dominating- K_4 , then G is 8-colorable.*

Proof. Let G be a connected (P_5, flag, K_5) -free graph. Suppose that G contains a dominating- K_4 , say K , induced by the vertex-set $\{v_1, v_2, v_3, v_4\}$. Let $C := \{v_1, v_2, v_3\}$. Then with respect to C , we define the sets A, B, T and Z as in Section 5.2, and we use the lemmas in Section 5.2. Since $v_4 \in Z$, we have $Z \neq \emptyset$. If $T \neq \emptyset$, then since T is anticomplete to Z (by Lemma 5.1:(iii)), K is not a dominating- K_4 in G , a contradiction; so $T = \emptyset$, and hence $V(G) = A \cup B \cup C \cup Z$. Note that, since G is (P_5, K_5) -free, for any $i \in \{1, 2, 3\}$, $G[N(v_i)]$ is (P_5, K_4) -free, and so by Theorem B, $G[N(v_i)]$ is 5-colorable. For $i \in \{1, 2, 3\}$, let L_i denote the set $A_{i+1} \cup A_{i-1} \cup B_i$, and let L'_i denote the set $L_i \cup \{v_i\}$. Then for $i \in \{1, 2, 3\}$, $N(v_i) = V(G) \setminus L'_i$. Since $\{v_i\}$ is anticomplete to L_i , we have $\chi(G[L'_i]) = \chi(G[L_i])$.

Now if there is an index $i \in \{1, 2, 3\}$ such that $G[L_i]$ is 3-colorable, say $i = 1$, then since $\chi(G) \leq \chi(G[V(G) \setminus L'_1]) + \chi(G[L'_1]) = \chi(G[V(G) \setminus L'_1]) + \chi(G[L_1]) = \chi(G[N(v_1)]) + 3 \leq 8$, and so G is 8-colorable and we are done.

So for each $i \in \{1, 2, 3\}$, we may assume that $\chi(G[L_i]) \geq 4$. Thus by Lemma 5.1:(i) and by Theorem A, we have, for each $i \in \{1, 2, 3\}$, both A_i and B_i are non-empty. Moreover, we claim the following:

5.6.1 Each A_i is a stable set.

Proof of 5.6.1. We will prove the claim for $i = 1$. Suppose not. Then there are adjacent vertices in A_1 , say a_1 and a'_1 . Let $a_2 \in A_2$. By Lemma 5.1:(ii), since $\{a_1, a'_1, v_1, a_2, v_4\}$ does not induce a flag, we have either $a_1a_2 \in E(G)$ or $a'_1a_2 \in E(G)$. Now, if $a_1a_2, a'_1a_2 \in E(G)$, then, again by Lemma 5.1:(ii), $\{a_1, a'_1, a_2, v_3, v_4\}$ induces a flag, a contradiction. So we may assume that

$a_1a_2 \in E(G)$ and $a'_1a_2 \notin E(G)$. Then $\{a'_1, a_1, a_2, v_2, v_3\}$ induces a P_5 , a contradiction. So 5.6.1 holds. ■

Also, since for each $i \in \{1, 2, 3\}$, $\chi(G[L_i]) \geq 4$, we see that, each B_i is not a stable set. Next we claim the following:

5.6.2 Z is a stable set.

Proof of 5.6.2. If there are adjacent vertices, say z_1 and z_2 in Z , then $\{v_1, v_2, v_3, z_1, z_2\}$ induces a K_5 , a contradiction. So 5.6.2 holds. ■

Next:

5.6.3 For each $i \in \{1, 2, 3\}$, $G[B_i]$ is a bipartite graph. In particular, for each $i \in \{1, 2, 3\}$, there are three stable sets, R_i , S_i and U_i , such that the following hold:

- (i) $B_i = S_i \cup R_i \cup U_i$.
- (ii) $G[R_i \cup S_i]$ is a connected bipartite graph.
- (iii) U_i is anticomplete to $R_i \cup S_i$.

Proof of 5.6.3. We will prove the claim for $i = 1$. Let $a_2 \in A_2$. Since B_1 is not a stable set, there are adjacent vertices in B_1 , say b and b' . By Lemma 5.1:(iv), we have $a_2b \in E(G)$, and so by Lemma 5.1:(i), $a_2b' \notin E(G)$. Let Q be the component of $G[B_1]$ containing b and b' . By Lemma 5.1:(i), $N(a_2) \cap V(Q)$ is a stable set, and, by Lemma 5.1:(iv), $V(Q) \setminus N(a_2)$ is a stable set. Now, we will show that $B_1 \setminus V(Q)$ is a stable set. If there are adjacent vertices in $B_1 \setminus V(Q)$, say u and u' , by Lemma 5.1:(iv), we may assume $a_2u \in E(G)$, and so by Lemma 5.1:(i), $a_2u' \notin E(G)$, and then $\{b', b, a_2, u, u'\}$ induces a P_5 , a contradiction; so $B_1 \setminus V(Q)$ is a stable set. Then the sets $R_1 := N(a_2) \cap V(Q)$, $S_1 := V(Q) \setminus N(a_2)$ and $U_1 := B_1 \setminus V(Q)$ are the desired sets. This proves 5.6.3. ■

Now, using 5.6.3, we claim the following:

5.6.4 We may assume that A_{i+1} is not anticomplete to R_i , and A_{i+1} is not anticomplete to S_i . Likewise, we may assume that A_{i-1} is not anticomplete to R_i , and A_{i-1} is not anticomplete to S_i .

Proof of 5.6.4. If A_{i+1} is anticomplete to R_i , then $\chi(G[L_i]) = \chi(G[A_{i+1} \cup R_i]) + \chi(G[S_i \cup U_i]) + \chi(G[A_{i-1}]) = 3$, a contradiction. So A_{i+1} is not anticomplete to R_i . Likewise, A_{i+1} is not anticomplete to S_i . This proves 5.6.4. ■

Next we claim the following:

5.6.5 For any $x \in A_{i+1} \cup A_{i-1} \cup Z$, if $N(x) \cap R_i \neq \emptyset$, then $\{x\}$ is complete to R_i , and $\{x\}$ is anticomplete to S_i . Likewise, for any $x \in A_{i+1} \cup A_{i-1} \cup Z$, if $N(x) \cap S_i \neq \emptyset$, then $\{x\}$ is complete to S_i , and $\{x\}$ is anticomplete to R_i .

Proof of 5.6.5. We will prove the claim for $i = 1$. Let $r \in R_1$ be such that $xr \in E(G)$. Let W denote the set $R_1 \cup S_1$. Note that, if $x \in A_2 \cup A_3$, by Lemma 5.1:(i) and Lemma 5.1:(iv), then $N(x) \cap W$ and $W \setminus N(x)$ are stable sets. We will now show that if $x \in Z$, then $N(x) \cap W$ and

$W \setminus N(x)$ are stable sets. If there are adjacent vertices, say $p, q \in N(x) \cap W$, then $\{p, q, v_2, v_3, x\}$ induces a K_5 , a contradiction. So $N(x) \cap W$ is a stable set. Now for any two adjacent vertices, say $l, m \in W \setminus N(x)$, and for any $a_2 \in A_2$, we may assume $l \in R_1$ and $m \in S_1$, then, by Lemma 5.1:(iv) and Lemma 5.1:(i), we have $a_2l \in E(G)$ and $a_2m \notin E(G)$. Then, by Lemma 5.1:(ii), $\{m, l, a_2, x, v_1\}$ induces a P_5 in G , a contradiction. This implies that $W \setminus N(x)$ is a stable set.

So the set $\{q \in W \mid \text{dist}(q, r) \text{ is odd}\}$ is anticomplete to $\{x\}$, and the set $\{q \in W \mid \text{dist}(q, r) \text{ is even}\}$ is complete to $\{x\}$. Since, $G[W]$ is a bipartite graph (by 5.6.3), $\{x\}$ is complete to R_1 , and $\{x\}$ is anticomplete to S_1 . This proves 5.6.5. ■

5.6.6 Z is either anticomplete to R_i or anticomplete to S_i .

Proof of 5.6.6. We will show the claim for $i = 1$. Suppose not, and let $r \in R_1$, $s \in S_1$, and $z_1, z_2 \in Z$ be such that $rz_1, sz_2 \in E(G)$. By 5.6.5, $rz_2, sz_1 \notin E(G)$. By 5.6.4, there are vertices, say $a_2, a'_2 \in A_2$ and $a_3, a'_3 \in A_3$ such that $N(a_2) \cap R_1, N(a_3) \cap R_1, N(a'_2) \cap S_1$ and $N(a'_3) \cap S_1$ are non-empty. Then, by 5.6.5, $a_2r, a_3r, a'_2s, a'_3s \in E(G)$ and $a_2s, a_3s, a'_2r, a'_3r \notin E(G)$. Since by Lemma 5.1:(ii), $\{a_2, a_3, r, v_1, z_1\}$ does not induce a flag, we have $a_2a_3 \notin E(G)$. Likewise, $a'_2a'_3 \notin E(G)$. Also, since by Lemma 5.1:(ii), $\{a_2, r, v_2, a'_3, z_1\}$ does not induce a flag, we have $a_2a'_3 \in E(G)$. Likewise, $a'_2a_3 \in E(G)$. Then, by 5.6.1, $\{a_2, a'_3, v_3, a_3, a'_2\}$ induces a P_5 , a contradiction. So 5.6.6 holds. ■

By 5.6.6 and up to relabeling, we may assume that Z is anticomplete to $S_1 \cup S_2 \cup S_3$. If for all $j \in \{1, 2, 3\}$, S_j is anticomplete to S_{j+1} , then, by 5.6.1, 5.6.2 and 5.6.3, we define the following stable sets: $D_1 := A_1 \cup \{v_2\}$, $D_2 := A_2 \cup \{v_3\}$, $D_3 := A_3 \cup \{v_1\}$, $D_4 := R_1 \cup U_1$, $D_5 := R_2 \cup U_2$, $D_6 := R_3 \cup U_3$ and $D_7 := S_1 \cup S_2 \cup S_3 \cup Z$. Clearly $V(G) = \bigcup_{k=1}^7 D_k$ and hence G is 7-colorable.

So we may assume that there is an index $j \in \{1, 2, 3\}$ such that S_j is not anticomplete to S_{j+1} ; let $j = 1$. Let $s_1 \in S_1$ and $s_2 \in S_2$ be adjacent. We let $A'_3 := \{a \in A_3 \mid N(a) \cap R_1 \neq \emptyset\}$. Then, by 5.6.5, A'_3 is complete to R_1 , and is anticomplete to S_1 . Since for any $a \in A'_3$, $\{s_1, s_2, v_1, v_4, a\}$ does not induce a P_5 , by Lemma 5.1:(ii), A'_3 is complete to $\{s_2\}$. So, by 5.6.5, A'_3 is anticomplete to R_2 . Now, by 5.6.3, we define the following stable sets: $D_1 := A_1 \cup \{v_3\}$, $D_2 := A_2 \cup \{v_1\}$, $D_3 := A'_3 \cup R_2 \cup \{v_2\}$, $D_4 := (A_3 \setminus A'_3) \cup R_1 \cup \{v_1\}$, $D_5 := S_1 \cup U_1$, $D_6 := S_2 \cup U_2$, $D_7 := R_3 \cup U_3$ and $D_8 := S_3 \cup Z$. Clearly, $V(G) = \bigcup_{k=1}^8 D_k$, and hence G is 8-colorable. This proves Theorem 5.6. □

Now we prove the main result of this section.

Theorem 5.7 *Every (P_5, flag, K_5) -free graph that contains a K_4 is 8-colorable.*

Proof. Let G be (P_5, flag, K_5) -free graph. Suppose that G contains a K_4 , say K . We may assume that G is connected, and by Theorem 5.4, we may assume that G is H_2 -free. We claim that K is a dominating- K_4 in G . Suppose to the contrary that K is a non-dominating- K_4 induced by the vertices, say v_1, v_2, v_3 , and v_4 . Then there is a vertex in $V(G) \setminus \{v_1, v_2, v_3, v_4\}$ which is anticomplete to $\{v_1, v_2, v_3, v_4\}$, say t , such that $\text{dist}(t, \{v_1, v_2, v_3, v_4\})$ is minimum. Let $C := \{v_1, v_2, v_3\}$. Then with respect to C , we define the sets A, B, T and Z as in Section 5.2, and we use the lemmas in Section 5.2. Since G is connected, by Lemma 5.1:(iii) and Lemma 5.1:(v), there is a vertex, say

$p \in A \cup B$ such that $pt \in E(G)$. Then, by Lemma 5.1:(ii), since $\{v_1, v_2, v_3, v_4, p, t\}$ does not induce an H_2 , we may assume that $p \in B_1$ and $pv_4 \in E(G)$, and then, by Lemma 5.1:(iii), $\{v_2, v_3, v_4, t, p\}$ induces a flag, a contradiction. So K is a dominating- K_4 in G , and we conclude the theorem by using Theorem 5.6. \square

5.5 Chromatic bound for (P_5, flag) -free graphs

In this section, we prove our result on chromatic bound for the class of (P_5, flag) -free graphs. First we prove the following.

Theorem 5.8 *If G is a connected (P_5, flag) -free graph, then either $\chi(G) \leq 8$ or G is $(K_1 + K_3)$ -free.*

Proof. Suppose that G is a connected (P_5, flag) -free graph. If G is triangle-free, then, by Theorem A, G is 3-colorable, and we are done. So we may assume that G contains a triangle. If every triangle in G is a dominating triangle in G , then clearly G is $(K_1 + K_3)$ -free, and again we are done. So we may assume that G contains a non-dominating-triangle. We claim that G is 8-colorable. By Theorem 5.5, we may assume that G is H_3 -free. Suppose that G contains a non-dominating K_3 , say with vertices v_1, v_2 , and v_3 . Let $C := \{v_1, v_2, v_3\}$. Then with respect to C , we define the sets A, B, T and Z as in Section 5.2, we use the lemmas in Section 5.2. Since $\{v_1, v_2, v_3\}$ induces a non-dominating- K_3 , we have $T \neq \emptyset$. Since for any $a \in A$ and $t' \in T$, $\{v_1, v_2, v_3, a, t'\}$ does not induce an H_3 , A is anticomplete to T . Since G is connected, by Lemma 5.1:(iii) and Lemma 5.1:(v), B is not anticomplete to T , and let $b^* \in B_1$ and $t \in T$ be such that $b^*t \in E(G)$. Now we show that G is K_5 -free. So $\omega(G) \leq 4$, and the theorem follows from Theorem 5.7. Suppose to the contrary that $\omega(G) \geq 5$. Let $K \subseteq V(G)$ be such that K induces a K_5 . Then the following claims hold:

5.8.1 $Z = \emptyset$.

Proof of 5.8.1. Suppose not, and let $z \in Z$. Then, by Lemma 5.1:(iii), $tz \notin E(G)$. Since $\{v_1, v_2, z, b^*, t\}$ does not induce an H_3 , we have $b^*z \in E(G)$. Then $\{v_2, v_3, z, t, b^*\}$ induces a flag, a contradiction. So 5.8.1 holds. \blacksquare

5.8.2 *For any $t' \in T$, we have $G[N(t')]$ is K_4 -free. So $K \cap T = \emptyset$.*

Proof of 5.8.2. Suppose not, and let $V' \subseteq N(t')$ be such that V' induces a K_4 . Since G is connected, by Lemma 5.1:(v), there is a vertex, say $b \in B$ such that $bt' \in E(G)$. Moreover, there is an index $i \in \{1, 2, 3\}$ such that $bv_{i+1} \in E(G)$ and $bv_i \notin E(G)$. Since for any $p \in T \cap V'$, by Lemma 5.1:(v), $\{p, t', b, v_{i+1}, v_i\}$ does not induce an H_3 , we have $V' \cap T = \emptyset$. Then, by Lemma 5.1:(i), we may assume that, there is an index $j \in \{1, 2, 3\}$, $|V' \cap B_j| = 2$ and $V' \cap (B_{j+1} \cup B_{j-1}) \neq \emptyset$. Let $p, q \in V' \cap B_j$. Then for any $r \in V' \cap (B_{j+1} \cup B_{j-1})$, $\{p, q, t', v_j, r\}$ induces a flag, a contradiction. So 5.8.2 holds. \blacksquare

5.8.3 *The vertex-set of any big component of $G[B_i]$ is complete to $\{t\}$.*

Proof of 5.8.3. Let V' be the vertex-set of a big component of $G[B_i]$. Then there are adjacent vertices in V' , say p and q . Suppose to the contrary that the claim is not true. Then by Lemma 5.1:(vi), we may assume that, V' is anticomplete to $\{t\}$ and hence $pt, qt \notin E(G)$. If $i = 1$, then, again by using Lemma 5.1:(vi), $b^*p, b^*q \notin E(G)$, and then $\{p, q, v_2, b^*, t\}$ induces an H_3 , a contradiction. Next, if $i = 2$, then since for any $v \in \{p, q\}$, $\{t, b^*, v_2, v_1, v\}$ does not induce a P_5 , we have $b^*p, b^*q \in E(G)$, and then $\{p, q, v_3, t, b^*\}$ induces a flag, a contradiction. We obtain a similar contradiction when $i = 3$. These contradictions show that 5.8.3 holds. ■

5.8.4 $K \cap C = \emptyset$.

Proof of 5.8.4. Suppose not, and let $v_1 \in K$. First, suppose that $v_2 \in K$. Then, by above claims, $K \cap (A \cup B_1 \cup B_2 \cup T \cup Z) = \emptyset$. So $|K| = |K \cap C| + |K \cap B_3|$. Now, if $v_3 \in K$, then $K \cap B_3 = \emptyset$, and hence $|K| = 3$, a contradiction, and if $v_3 \notin K$, then, by Lemma 5.1:(i), $|K| \leq 4$, a contradiction. So we conclude that $v_2 \notin K$. Likewise, $v_3 \notin K$. Next, since $v_1 \in K$ and $v_2, v_3 \notin K$, by above claims, $K \cap (A_2 \cup A_3 \cup B_1 \cup T \cup Z) = \emptyset$. Also, by 5.8.2 and by 5.8.3, one of $|K \cap B_2|$ or $|K \cap B_3|$ is at most 1; say $|K \cap B_2| \leq 1$. Then, by Lemma 5.1:(i), we see that $|K| \leq 4$, a contradiction. So 5.8.4 holds. ■

5.8.5 $K \cap (C \cup T \cup Z) = \emptyset$.

Proof of 5.8.5. This follows from 5.8.1, 5.8.2 and 5.8.4. ■

5.8.6 For each i , we have $|K \cap A_i| \leq 1$.

Proof of 5.8.6. Suppose not, and let $p, q \in K \cap A_i$. Then, by Lemma 5.1:(i), $K \cap (B_{i+1} \cup B_{i-1}) = \emptyset$, and $K \cap A_i = \{p, q\}$. Since, by Lemma 5.1:(i), $|K \cap B_i| \leq 2$, we have $K \cap (A_{i+1} \cup A_{i-1}) \neq \emptyset$. Then, for any $r \in K \cap (A_{i+1} \cup A_{i-1})$, $\{p, q, r, v_{i+1}, v_{i-1}\}$ induces an H_3 , a contradiction. So 5.8.6 holds. ■

5.8.7 For each i , we have $|K \cap (A_{i+1} \cup A_{i-1} \cup B_i)| \leq 2$.

Proof of 5.8.7. Suppose not, and let $p, q, r \in K \cap (A_{i+1} \cup A_{i-1} \cup B_i)$. Then, by 5.8.6, $|K \cap A_{i+1}| \leq 1$. Likewise, $|K \cap A_{i-1}| \leq 1$. Since, by Lemma 5.1:(i), $|K \cap (A_{i+1} \cup B_i)| \leq 2$, we conclude that $|K \cap (A_{i+1} \cup A_{i-1} \cup B_i)| \leq 3$. Then, by 5.8.5, there is a vertex, say $s \in K \cap (A_i \cup B_{i+1} \cup B_{i-1})$, and then $\{p, q, r, v_i, s\}$ induces a flag, a contradiction. So 5.8.7 holds. ■

5.8.8 There is an index $j \in \{1, 2, 3\}$ such that $|K \cap B_j| = 2$.

Proof of 5.8.8. Suppose not, then for each $j \in \{1, 2, 3\}$, we have $|K \cap B_j| \leq 1$. So $|K \cap B| \leq 3$. Then, by 5.8.5, $|K \cap A| \geq 2$. Also, by 5.8.7, $|K \cap A| \leq 3$. If $|K \cap A| = 3$, then by 5.8.7, for each $i \in \{1, 2, 3\}$, $K \cap A_i \neq \emptyset$, and thus, by 5.8.7, $K \cap B = \emptyset$ which implies that $|K| = 3$, a contradiction. So we have $|K \cap A| = 2$ and $|K \cap B| = 3$. So for each $r \in \{1, 2, 3\}$, $K \cap B_r \neq \emptyset$. Since $|K \cap A| = 2$, there is an index $\ell \in \{1, 2, 3\}$ such that $K \cap A_\ell \neq \emptyset$. Since $K \cap B_{\ell+1} \neq \emptyset$ and $K \cap B_{\ell-1} \neq \emptyset$, by 5.8.7, we have $K \cap (A_{\ell+1} \cup A_{\ell-1}) = \emptyset$ and $|K \cap A_\ell| = 1$. So $|K \cap A| \leq 1$, a contradiction. So 5.8.8 holds. ■

Let $K = \{r_1, r_2, r_3, r_4, r_5\}$. By 5.8.8, we may assume $r_1, r_2 \in B_1$. So, by 5.8.7, $\{r_3, r_4, r_5\} \cap (A_2 \cup A_3) = \emptyset$; hence, by 5.8.5, $r_3, r_4, r_5 \in A_1 \cup B_2 \cup B_3$. Also, by 5.8.3, $r_1t, r_2t \in E(G)$. Then, by 5.8.2, $|N(t) \cap \{r_3, r_4, r_5\}| \leq 1$. Note that $\{r_3, r_4, r_5\}$ is complete to $\{v_1\}$. Since $\{r_4, r_5, v_1, t, r_3\}$ does not induce a flag, we have $\{r_3, r_4, r_5\}$ is anticomplete to $\{t\}$. Then $\{r_3, r_4, r_5, t, r_1\}$ induces a flag, a contradiction. Thus $\omega(G) \leq 4$, and the theorem follows from Theorem 5.7. This completes the proof of Theorem 5.8. \square

Theorem 5.9 *Every (P_5, flag) -free graph G with $\omega(G) \geq 4$ satisfies $\chi(G) \leq \max\{8, 2\omega(G) - 3\}$.*

Proof. Let G be a (P_5, flag) -free graph. We may assume that G is connected. If G contains a $K_1 + K_3$, then, by Theorem 5.8, G is 8-colorable. So we may assume that G is $K_1 + K_3$ -free. Then the theorem follows from Theorem J and Theorem 5.7. \square

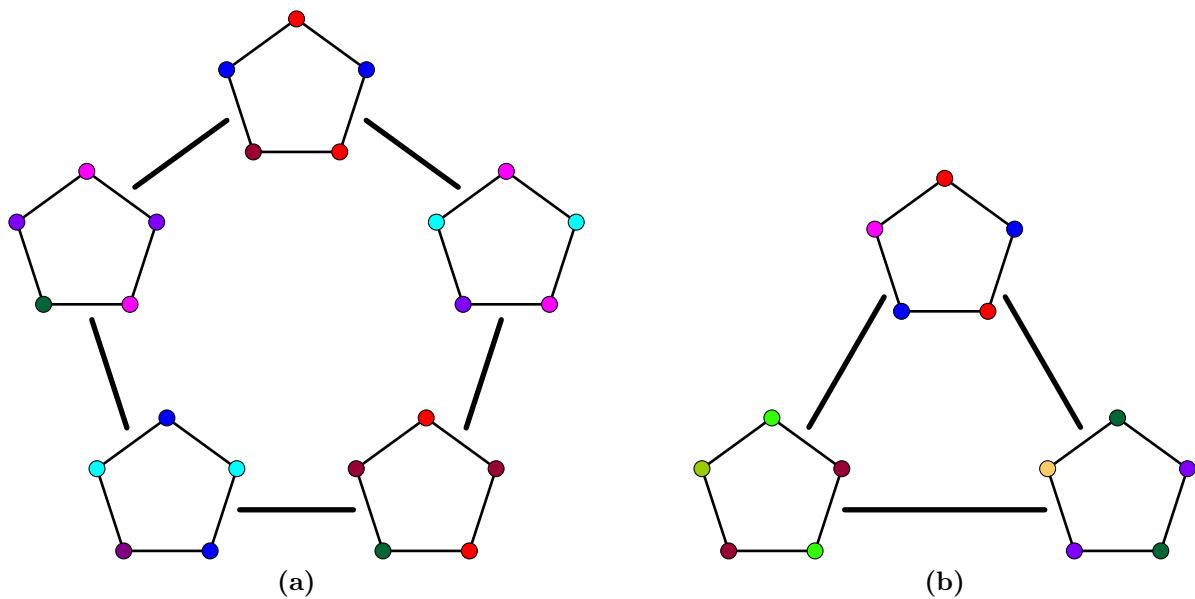

Figure 21: (a) The graph $C_5[C_5]$ with an 8-coloring. (b) The graph $3\overline{C_5}$ with a 9-coloring. (Here, the thick lines between any two C_5 's indicate their join.)

We note that the bound in Theorem 5.9 is tight for the $\omega(G) \in \{4, 5, 6\}$. To do that, we need the following:

Theorem 5.10 *The graph $H^* \cong C_5[C_5]$ is (P_5, flag) -free with $\omega(H^*) = 4$ and $\chi(H^*) = 8$.*

Proof. Recall that $V(H^*)$ can be partitioned into 5 subsets A_1, \dots, A_5 such that (i) A_i induces a C_5 , (ii) for each $i \pmod 5$, every vertex in A_i is adjacent to every vertex in $A_{i+1} \cup A_{i-1}$ and to no vertex in $A_{i+2} \cup A_{i-2}$. It is easy to verify that H^* is (P_5, flag) -free with $\omega(H^*) = 4$ and $\alpha(H^*) = 4$. So it is enough to show that $\chi(H^*) = 8$. Since $\chi(H^*) \geq \left\lceil \frac{|V(H^*)|}{\alpha(H^*)} \right\rceil = \left\lceil \frac{25}{4} \right\rceil = 7$, we see that at least 7 colors are required to color H^* . Moreover, from Figure 21, we conclude that $\chi(H^*)$ is either 7 or 8. Suppose to the contrary that $\chi(H^*) = 7$. Then $V(H^*)$ can be partitioned into 7 stable sets, say D_1, D_2, \dots , and D_7 .

For $i \in \{1, 2, 3, 4, 5\}$ and $i \bmod 5$, we let $L_i := \{j \in \{1, 2, \dots, 7\} \mid A_i \cap D_j \neq \emptyset\}$. Since for each i , A_i induces a C_5 , we have $|L_i| \geq 3$ and thus $|L_i| + |L_{i+1}| \geq 6$. Since A_i is complete to A_{i+1} , we have $L_i \cap L_{i+1} = \emptyset$ and thus $|L_i| + |L_{i+1}| \leq 7$. If for each $i \in \{1, 2, 3, 4, 5\}$, $|L_i| + |L_{i+1}| = 7$, there is an index $k \in \{1, 2, 3, 4, 5\}$, $k \bmod 5$, such that $|L_k| = 4$ and $|L_{k+1}| = 4$ which implies that $|L_k| + |L_{k+1}| = 8$ which is a contradiction; so there is an index $i \in \{1, 2, 3, 4, 5\}$, $i \bmod 5$, such that $|L_i| = 3$ and $|L_{i+1}| = 3$. Without loss of generality, we may assume that $L_1 = \{1, 2, 3\}$ and $L_2 = \{4, 5, 6\}$. If $7 \notin L_3$, then $L_3 = \{1, 2, 3\}$ and so $\{1, 2, 3\} \cap (L_4 \cup L_5) = \emptyset$ which is a contradiction to the fact $|L_4| + |L_5| \geq 6$; so $7 \in L_3$. Likewise, $7 \in L_5$. Since $|L_3| \geq 3$ and $L_2 \cap L_3 = \emptyset$, we have $|L_3 \cap \{1, 2, 3\}| \geq 2$; so we may assume that $\{1, 2\} \subseteq L_3$. Likewise, we may assume that $\{4, 5\} \subseteq L_5$. Since $L_4 \cap (L_3 \cup L_5) = \emptyset$, we have $\{1, 2, 4, 5, 7\} \cap L_4 = \emptyset$ and hence $|L_4| \leq 2$, a contradiction to the fact $|L_4| \geq 3$. So $\chi(H^*) = 8$. \square

Now we show that the bound given in Theorem 5.9 is tight for $\omega(G) \in \{4, 5, 6\}$.

- For $\omega(G) = 4$, we consider the graph $G \cong C_5[C_5]$. Then by Theorem 5.10, $\chi(G) = 8$.
- For $\omega(G) = 5$, we consider the graph $G \cong C_5[C_5] + K_5$. Then by Theorem 5.10, $\chi(G) = \max\{\chi(C_5[C_5]), 5\} = 8$.
- For $\omega(G) = 6$, we consider the graph $G \cong \overline{3C_5}$ (see Figure 21). Then clearly $\chi(G) = 9$.

5.6 Concluding remarks

In this chapter, we studied the structure of (P_5, flag) -free graphs and showed that each such connected graph is either 8-colorable or $K_1 + K_3$ -free (see Theorem 5.8). We explored the coloring of (P_5, flag) -free graphs and proved that every such graph G with $\omega(G) \geq 4$ satisfies $\chi(G) \leq \max\{8, 2\omega(G) - 3\}$ and that the bound is tight for $\omega(G) \in \{4, 5, 6\}$. The bound does not seem to be tight for $\omega(G) \geq 7$.

From Theorem 5.8, it follows that, if f^* is the smallest χ -binding function for the class of $(P_5, K_1 + K_3)$ -free graphs, then, for $x \geq 4$, $f(x) = \max\{8, f^*(x)\}$ is the smallest χ -binding function for the class of (P_5, flag) -free graphs. We believe that (see also [91]) the function $f(x) = \lfloor \frac{3x}{2} \rfloor$ is the smallest χ -binding function for the class of $(P_5, K_1 + K_3)$ -free graphs \mathcal{G} , since given $t \in \mathbb{N}$, for $\omega(G) = 2t$, we have $G = \overline{tC_5}$, and for $\omega(G) = 2t + 1$, we have $G = \overline{tC_5} \vee K_1$ so that $G \in \mathcal{G}$ and that $\chi(G) = \lfloor \frac{3\omega(G)}{2} \rfloor$. Moreover, to find the smallest χ -binding function for the class of $(P_5, K_1 + K_3)$ -free graphs, it is enough to find the smallest χ -binding function for the class of $(2P_2, K_1 + K_3, K_1 + C_5)$ -free graphs [21].

Bibliography

- [1] K. Appel and A. Haken, Every planar map is four colorable. Part I. Discharging. *Illinois Journal of Mathematics* 21 (1977) 429–490.
- [2] K. Appel, A. Haken and J. Koch, Every planar map is four colorable. Part II. Reducibility. *Illinois Journal of Mathematics* 21 (1977) 491–567.
- [3] N. R. Aravind, T. Karthick and C. R. Subramanian, Bounding χ in terms of ω and Δ for some classes of graphs. *Discrete Mathematics* 311 (2011) 911–920.
- [4] G. Bacsó and Zs. Tuza, Dominating cliques in P_5 -free graphs. *Periodica Mathematica Hungarica* 21 (1990) 303–308.
- [5] G. Bacsó and Zs. Tuza, A characterization of graphs without long induced paths. *Journal of Graph Theory* 14 (1990) 455–464.
- [6] C. Berge, Färbung von Graphen, deren sämtliche bzw. deren ungerade Kreise starr sind, *Wiss. Z., Martin-Luther-Univ. Halle-Wittenberg, Math.-Naturwiss. Reihe* 10 (1961) 114.
- [7] C. Berge, Perfect graphs. In: *Six Papers on Graph Theory*. Indian Statistical Institute, Calcutta (1963) 1–21.
- [8] A. P. Bharathi and S. A. Choudum, Colouring of $(P_3 \cup P_2)$ -free graphs. *Graphs and Combinatorics* 34 (2018) 97–107.
- [9] Z. Blázsik, M. Hujter, A. Pluhár and Zs. Tuza, Graphs with no induced C_4 and $2K_2$. *Discrete Mathematics* 115 (1993) 51–55.
- [10] H. L. Bodlaender, A. Brandstädt, D. Kratsch, M. Rao and J. Spinrad, On algorithms for (P_5, gem) -free graphs. *Theoretical Computer Science* 349 (2005) 2–21.
- [11] J. A. Bondy and U. S. R. Murty. *Graph Theory*. Springer, 2013.
- [12] F. Bonomo, M. Chudnovsky, P. Maceli, O. Schaudt, M. Steinz and M. Zhong, Three-coloring and list three-coloring of graphs without induced paths on seven vertices. *Combinatorica* 38 (2018) 779–801.
- [13] F. Bonomo, M. Chudnovsky, J. Goedgebeur, P. Maceli, O. Schaudt, M. Steinz and M. Zhong, Better 3-coloring algorithms: Excluding a triangle and a seven vertex path. *Theoretical Computer Science* 850 (2021) 98–115.

- [14] A. Brandstädt, $(P_5, \text{diamond})$ -free graphs revisited: structure and linear time optimization. *Discrete Applied Mathematics* 138 (2004) 13–27.
- [15] A. Brandstädt and C. T. Hoàng, On clique separators, nearly chordal graphs, and the maximum weight stable set problem. *Theoretical Computer Science* 389 (2007) 295–306.
- [16] A. Brandstädt and D. Kratsch, On the structure of (P_5, gem) -free graphs. *Discrete Applied Mathematics* 145 (2005) 155–162.
- [17] A. Brandstädt, H. Le and R. Mosca, Gem- and co-gem-free graphs have bounded clique-width. *International Journal of Foundations of Computer Science* 15 (2004) 163–185.
- [18] A. Brandstädt and R. Mosca, On the structure and stability number of P_5 - and co-chair-free graphs. *Discrete Applied Mathematics* 132 (2004) 47–65.
- [19] S. Brandt, Triangle-free graphs without forbidden subgraphs. *Discrete Applied Mathematics* 120 (2002) 25–33.
- [20] C. Brause, T. Doan and I. Schiermeyer, On the chromatic number of $(P_5, K_{2,t})$ -free graphs. *Electronic Notes in Discrete Mathematics* 55 (2016) 127–130.
- [21] C. Brause and M. Geißer, On graphs without an induced path on 5 vertices and without an induced dart or kite. In: J. Nešetřil, G. Perarnau, J. Rué and O. Serra (Eds). *Extended Abstracts of EUROCOMB 2021. Trends in Mathematics*, Birkhäuser, Cham. 14 (2021) 311–317.
- [22] C. Brause, B. Randerath, I. Schiermeyer and E. Vumar, On the chromatic number of $2K_2$ -free graphs. *Discrete Applied Mathematics* 253 (2019) 14–24.
- [23] M. Briański, J. Davies and B. Walczak, Separating polynomial χ -boundedness from χ -boundedness. *Combinatorica* 44 (2024) 1–8.
- [24] H. Broersma, P. A. Golovach, D. Paulusma and J. Song, Updating the complexity status of coloring graphs without a fixed induced linear forest. *Theoretical Computer Science* 414 (2012) 9–19.
- [25] R. L. Brooks, On colouring the nodes of a network. *Proceedings of the Cambridge Philosophical Society* 37 (1941) 194–197.
- [26] J. I. Brown and D. G. Corneil, Perfect colorings. *Ars Combinatoria* 30 (1990) 141–159.
- [27] K. Cameron, S. Huang and O. Merkel, An optimal χ -bound for $(P_6, \text{diamond})$ -free graphs. *Journal of Graph Theory* 97 (2021) 451–465.
- [28] K. Cameron, S. Huang and O. Merkel, A bound for the chromatic number of (P_5, gem) -free graphs. *Bulletin of the Australian Mathematical Society* 100 (2019) 182–188.

- [29] K. Cameron and K. Vušković, Hadwiger’s conjecture for some hereditary classes of graphs: A survey. *The Algorithmics Column* by Thomas Erlebach, European Association for Theoretical Computer Science 131 (2020).
- [30] S. A. Choudum and T. Karthick, First-fit coloring of $\{P_5, K_4 - e\}$ -free graphs. *Discrete Applied Mathematics* 158 (2010) 620–626.
- [31] S. A. Choudum and T. Karthick, Maximal cliques in $\{P_2 \cup P_3, C_4\}$ -free graphs. *Discrete Mathematics* 310 (2010) 3398–3403.
- [32] S. A. Choudum, T. Karthick and M. A. Shalu, Perfect coloring and linearly χ -bound P_6 -free graphs. *Journal of Graph Theory* 54 (2007) 293–306.
- [33] S. A. Choudum, T. Karthick and M. A. Shalu, Linear chromatic bounds for a subfamily of $3K_1$ -free graphs. *Graphs and Combinatorics* 24 (2008) 413–428.
- [34] S. A. Choudum and M. A. Shalu, The class of $\{3K_1, C_4\}$ -free graphs. *Australasian Journal of Combinatorics* 32 (2005) 111–116.
- [35] M. Chudnovsky, The Erdős-Hajnal conjecture—A Survey. *Journal of Graph Theory* 75 (2014) 178–190.
- [36] M. Chudnovsky, L. Cook and P. Seymour, Excluding the fork and antifork. *Discrete Mathematics* 343 (2020) Article No.: 111786.
- [37] M. Chudnovsky, G. Cornuéjols, X. Liu, P. Seymour and K. Vušković, Recognizing Berge graphs. *Combinatorica* 25 (2005) 143–186.
- [38] M. Chudnovsky, L. Esperet, L. Lemoine, P. Maceli, F. Maffray and I. Penev, Graphs with no induced five-vertex path or antipath. *Journal of Graph Theory* 84 (2017) 221–232.
- [39] M. Chudnovsky, T. Karthick, P. Maceli and F. Maffray, Coloring graphs with no induced five-vertex path or gem. *Journal of Graph Theory* 95 (2020) 527–542.
- [40] M. Chudnovsky and A. Ovetsky, Coloring quasi-line graphs. *Journal of Graph Theory* 54 (2007) 41–50.
- [41] M. Chudnovsky, I. Penev, A. Scott and N. Trotignon, Substitution and χ -boundedness. *Journal of Combinatorial Theory, Series B* 103 (2013) 567–586.
- [42] M. Chudnovsky, N. Robertson, P. Seymour and R. Thomas, The strong perfect graph theorem. *Annals of Mathematics* 164 (2006) 51–229.
- [43] M. Chudnovsky and M. Safra, The Erdős–Hajnal conjecture for bull-free graphs. *Journal of Combinatorial Theory, Series B* 98 (2008) 1301–1310.
- [44] M. Chudnovsky, A. Scott, P. Seymour and S. Spirkl, Erdős–Hajnal for graphs with no 5-hole. *Proceedings of the London Mathematical Society* 126 (2023) 837–1062.

- [45] M. Chudnovsky and P. Seymour, The Structure of Claw-free Graphs. *Surveys in Combinatorics*, London Mathematical Society (Lecture Notes Series) 327 (2005) 153–171.
- [46] M. Chudnovsky and P. Seymour, Claw-free graphs VI. Colouring. *Journal of Combinatorial Theory, Series B* 100 (2010) 560–572.
- [47] M. Chudnovsky, P. Seymour, S. Spirkl and M. Zhong, Triangle-free graphs with no six-vertex induced path. *Discrete Mathematics* 341 (2018) 2179–2196.
- [48] M. Chudnovsky, A. Scott and P. Seymour, Induced subgraphs of graphs with large chromatic number. XII. Distant stars. *Journal of Graph Theory* 92 (2019) 237–254.
- [49] M. Chudnovsky and V. Sivaraman, Perfect divisibility and 2-divisibility. *Journal of Graph Theory* 90 (2019) 54–60.
- [50] M. Chudnovsky, S. Spirkl and M. Zhong, Four-coloring P_6 -free graphs. In: *Proceedings of SODA 2019* (2019) 1239–1256.
- [51] F.R.K. Chung, On the covering of graphs. *Discrete Mathematics* 30 (1980) 89–93.
- [52] V. Chvátal, The smallest triangle-free 4-chromatic 4-regular graph. *Journal of Combinatorial Theory, Series B* 9 (1970) 93–94.
- [53] D. G. Corneil, H. Lerchs and L. Stewart Burlingham, Complement reducible graphs. *Discrete Applied Mathematics* 3 (1981) 163–74.
- [54] B. Descartes, Solution to advanced problem No. 4526. *American Mathematical Monthly* 61 (1954) 352.
- [55] W. Dong, B. Xu and Y. Xu, On the chromatic number of some P_5 -free graphs. *Discrete Mathematics* 345 (2022) Article No.: 113004.
- [56] W. Dong, B. Xu, and Y. Xu, A tight linear bound to the chromatic number of $(P_5, K_1 + (K_1 \cup K_3))$ -free graphs. *Graphs and Combinatorics* 39 (2023) Article No.: 43.
- [57] P. Erdős, Some remarks on the theory of graphs. *Bulletin of the American Mathematical Society* 53 (1947) 292–294.
- [58] P. Erdős, Remarks on a theorem of Ramsey. *Bulletin of the Research Council of Israel, Section F7* (1957-58) 21–24.
- [59] P. Erdős, Graph theory and probability. *Canadian Journal of Mathematics* 11 (1958) 34–38.
- [60] P. Erdős and A. Hajnal, Embedding theorems for graphs establishing negative partition relations. University of Calgary, Research Paper No. 307 (1976).
- [61] P. Erdős and A. Hajnal, Ramsey-type theorems. *Discrete Applied Mathematics* 25 (1989) 37–52.

- [62] L. Esperet, Graph Colorings, Flows and Perfect Matchings. Habilitation Thesis. Université Grenoble Alpes (2017).
- [63] L. Esperet, L. Lemoine, F. Maffray, and M. Morel, The chromatic number of $\{P_5, K_4\}$ -free graphs. *Discrete Mathematics* 313 (2013) 743–754.
- [64] R. Faudree, E. Flandrin and Z. Ryjacek, Claw-free graphs: a survey. *Discrete Mathematics* 164 (1997) 87–147.
- [65] U. Feige and J. Kilian, Zero knowledge and chromatic number. *Journal of Computer and System Sciences* 57 (1998) 187–199.
- [66] S. Földes and P. L. Hammer, Split graphs. In: *Proceedings of the Eighth South-Eastern Conference on Combinatorics, Graph Theory and Computing, Congressus Numerantium XIX*, Utilitas Mathematics, Winnipeg (1977) 311–315.
- [67] J. -L. Fouquet, A decomposition for a class of $(P_5, \overline{P_5})$ -free graphs. *Discrete Mathematics* 121 (1993) 75–83.
- [68] J. -L. Fouquet, V. Giakoumakis, F. Maire and H. Thuillier, On graphs without P_5 and $\overline{P_5}$. *Discrete Mathematics* 146 (1995) 33–44.
- [69] J. -L. Fouquet, J. M. Vanherpe, Reed’s conjecture on some special classes of graphs. Preprint (2012). Available on: arXiv:1205.0730v2 [cs.DM].
- [70] D. R. Fulkerson, On the perfect graph theorem. *Mathematical Programming*, T. C. Hu and S. M. Robinson eds., Academic Press (1973) 69–76.
- [71] G. S. Gasparian, Minimal imperfect graphs: A simple approach. *Combinatorica* 16 (1996) 209–212.
- [72] S. Gaspers and S. Huang, Linearly χ -bounding (P_6, C_4) -free graphs. *Journal of Graph Theory* 92 (2019) 322–342.
- [73] S. Gaspers and S. Huang, $(2P_2, K_4)$ -free graphs are 4-colorable. *SIAM Journal on Discrete Mathematics* 33 (2019) 1095–1120.
- [74] M. Geißer, Colourings of P_5 -free graphs. PhD. Thesis. Technische Universität Bergakademie Freiberg (2022).
- [75] D. Gernet and L. Rabern, A computerized system for graph theory, illustrated by partial proofs for graph-coloring problems. *Graph Theory Notes of New York*, LV (2008) 14–24.
- [76] J. Goedgebeur, S. Huang, Y. Ju and O. Merkel, Colouring graphs with no induced six-vertex path or diamond. *Theoretical Computer Science* 941 (2023) 278–299.

- [77] P. A. Golovach, M. Johnson, D. Paulusma and J. Song, A survey on the computational complexity of colouring graphs with forbidden subgraphs. *Journal of Graph Theory* 84 (2017) 331–363.
- [78] M. C. Golumbic, *Algorithmic Graph Theory and Perfect Graphs* (2nd Edition). *Annals of Discrete Mathematics*, Elsevier, Amsterdam (2004).
- [79] S. Gravier, C. T. Hoàng and F. Maffray, Coloring the hypergraph of maximal cliques of a graph with no long path. *Discrete Mathematics* 272 (2003) 285–290.
- [80] M. Grötschel, L. Lovász and A. Schrijver, The ellipsoid method and its consequences in combinatorial optimization. *Combinatorica* 1 (1981) 169–197. Corrigendum: *Combinatorica* 4 (1984) 291–295.
- [81] A. Gyárfás, Problems from the world surrounding perfect graphs. *Zastosowania Matematyki Applicationes Mathematicae* 19 (1987) 413–441.
- [82] A. Gyárfás and J. Lehel, On-line and first fit colorings of graphs. *Journal of Graph Theory* 12 (1988) 217–227.
- [83] H. Hadwiger, Über eine Klassifikation der Streckenkomplexe. *Vierteljahrsschrift der Naturforschenden Gesellschaft in Zürich* 88 (1943) 133–143.
- [84] M. A. Henning, C. Löwenstein and D. Rautenbach, Independent sets and matchings in subcubic graphs. *Discrete Mathematics* 312 (2012) 1900–1910.
- [85] C. T. Hoàng, On the structure of (banner, odd hole)-free graphs. *Journal of Graph Theory* 89 (2018) 395–412.
- [86] C. T. Hoàng, M. Kamiński, V.V. Lozin, J. Sawada and X. Shu, Deciding k -colorability of P_5 -free graphs in polynomial time. *Algorithmica* 57 (2010) 74–81.
- [87] C. T. Hoàng and C. McDiarmid, On the divisibility of graphs. *Discrete Mathematics* 242 (2002) 145–156.
- [88] I. Holyer, The NP -completeness of edge coloring. *SIAM Journal on Computing* 10 (1981) 718–720.
- [89] S. Hougardy, Classes of perfect graphs. *Discrete Mathematics* 306 (2006) 2529–2571.
- [90] S. Huang, Improved complexity results on k -coloring P_t -free graphs. *European Journal of Combinatorics* 51 (2016) 336–346.
- [91] S. Huang, Y. Ju and T. Karthick, Coloring (P_5, kite) -free graphs with small cliques. *Discrete Applied Mathematics* 344 (2024) 129–139.
- [92] S. Huang and T. Karthick, On graphs with no induced five-vertex path or paraglider. *Journal of Graph Theory* 97 (2021) 305–323.

- [93] T. R. Jensen and B. Toft, *Graph Coloring Problems*, Wiley, New York (1994).
- [94] F. Joos, Independence and matching number in graphs with maximum degree 4. *Discrete Mathematics* 323 (2014) 1–6.
- [95] Y. Ju and S. Huang, Near optimal colourability on hereditary graph families. *Theoretical Computer Science* 993 (2024) Article No.: 114465.
- [96] M. Kamiński and V. Lozin, Coloring edges and vertices of graphs without short or long cycles. *Contributions to Discrete Mathematics* 2 (2007) 61–66.
- [97] R. M. Karp, Reducibility among combinatorial problems. In: *Complexity of Computer Computations*, R. E. Miller and J. W. Thatcher (Eds), Plenum Press, New York (1972) 85–103.
- [98] T. Karthick, Star Coloring of certain graph classes. *Graphs and Combinatorics* 34 (2018) 109–128.
- [99] T. Karthick, J. Kaufmann and V. Sivaraman, Coloring graph classes with no induced fork via perfect divisibility. *The Electronic Journal of Combinatorics* 29 (2022) #P3.19.
- [100] T. Karthick and F. Maffray, Vizing Bound for the chromatic number on some graph classes. *Graphs and Combinatorics* 32 (2016) 1447–1460.
- [101] T. Karthick and F. Maffray, Coloring (gem, co-gem)-free graphs. *Journal of Graph Theory* 89 (2018) 288–303.
- [102] T. Karthick and F. Maffray, Square-free graphs with no six-vertex induced path. *SIAM Journal on Discrete Mathematics* 33 (2019) 874–909.
- [103] T. Karthick, F. Maffray and L. Pastor, Polynomial cases for the vertex coloring problem. *Algorithmica* 81 (2019) 1053–1074.
- [104] T. Karthick and S. Mishra, Chromatic bounds for some classes of $2K_2$ -free graphs. *Discrete Mathematics* 341 (2018) 3079–3088.
- [105] T. Karthick and S. Mishra, On the chromatic number of $(P_6, \text{diamond})$ -free graphs. *Graphs and Combinatorics* 34 (2018) 677–692.
- [106] K. Kawarabayashi, Hadwiger’s conjecture. *Topics in Chromatic Graph Theory*, 73–93, *Encyclopedia of Mathematics and its Applications* 156, Cambridge University Press, Cambridge, 2015.
- [107] S. Khanna, N. Linial and S. Safra, On the hardness of approximating the chromatic number. *Combinatorica* 20 (2000) 393–415.
- [108] H. A. Kierstead, On the chromatic index of multigraphs without large triangles. *Journal of Combinatorial Theory, Series B* 36 (1984) 156–160.

- [109] H. A. Kierstead and S. G. Penrice, Radius two trees specify χ -bounded classes. *Journal of Graph Theory* 18 (1994) 119–129.
- [110] H. A. Kierstead, S. G. Penrice and W. T. Trotter, On-line and first-fit coloring of graphs that do not induce P_5 . *SIAM Journal of Discrete Mathematics* 8 (1995) 485–498.
- [111] H. A. Kierstead and J. H. Schmerl, The chromatic number of graphs which induce neither $K_{1,3}$ nor $K_5 - e$. *Discrete Mathematics* 58 (1986) 253–262.
- [112] H. A. Kierstead and Y. Zhu, Radius three trees in graphs with large chromatic number. *SIAM Journal on Discrete Mathematics* 17 (2004) 571–581.
- [113] J. H. Kim, The Ramsey number $R(3, t)$ has order of magnitude $t^2/\log t$. *Random Structures & Algorithms* 7 (1995) 173–207.
- [114] A. D. King, Claw-free graphs and two conjectures on ω , Δ , and χ . PhD. Thesis. McGill University, Montreal, Canada (2009).
- [115] A. D. King, Hitting all maximum cliques with a stable set using lopsided independent transversals. *Journal of Graph Theory* 67 (2011) 300–305.
- [116] A. D. King, B. Reed and A. Vetta, An upper bound for the chromatic number of line graphs. *European Journal of Combinatorics* 28 (2007) 2182–2187.
- [117] T. Kloks, H. Müller and K. Vušković, Even-hole-free graphs that do not contain diamonds: a structure theorem and its consequences. *Journal of Combinatorial Theory, Series B* 99 (2009) 733–800.
- [118] A. Kohl and I. Schiermeyer, Some results on Reed’s Conjecture about ω , Δ and χ with respect to α . *Discrete Mathematics* 310 (2010) 1429–1438.
- [119] D. Kral, J. Kratochvíl, Z. Tuza and G. J. Woeginger, Complexity of coloring graphs without forbidden induced subgraphs. In: *WG 2001, Lecture Notes in Computer Science* 2204 (2001) 254–262.
- [120] M. Kubale (Ed.), *Graph colorings. Contemporary Mathematics*, American Mathematical Society, Providence, Rhode Island 352 (2004).
- [121] K. Kuratowski, Sur le problème des courbes gauches en topologie. *Fundamenta Mathematicae* 15 (1930) 271–283.
- [122] V. B. Le, B. Randerath and I. Schiermeyer, On the complexity of 4-coloring graphs without long induced paths. *Theoretical Computer Science* 389 (2007) 330–335.
- [123] D. Leven and Z. Galil, NP-completeness of finding the chromatic index of regular graphs. *Journal of Algorithms* 4 (1983) 35–44.

- [124] X. Liu, J. Schroeder, Z. Wang and X. Yu, Polynomial χ -binding functions for t -broom-free graphs. *Journal of Combinatorial Theory, Series B* 162 (2023) 118–133.
- [125] L. Lovász, A characterization of perfect graphs. *Journal of Combinatorial Theory, Series B* 13 (1972) 95–98.
- [126] L. Lovász, Normal hypergraphs and the perfect graph conjecture. *Discrete Mathematics* 2 (1972) 253–267.
- [127] L. Lovász, On the Shannon capacity of a graph. *IEEE Transactions on Information Theory* 25 (1979) 1–7.
- [128] C. Lund and M. Yannakakis, On the hardness of approximating minimization problems. *Journal of the Association for Computing Machinery* 41 (1994) 960–981.
- [129] F. Maffray and M. Preissmann, Linear recognition of pseudo-split graphs. *Discrete Applied Mathematics* 52 (1994) 307–312.
- [130] F. Maffray and M. Preissmann, On the NP-completeness of the k -colorability problem for triangle-free graphs. *Discrete Mathematics* 162 (1996) 313–317.
- [131] D. S. Malyshev, Two cases of polynomial-time solvability for the coloring problem. *Journal of Combinatorial Optimization* 31 (2016) 833–845.
- [132] D. S. Malyshev and O. Lobanova, Two complexity results for the vertex coloring problem. *Discrete Applied Mathematics* 219 (2017) 158–166.
- [133] D. Marx, Graph coloring with local and global constraints. PhD. Thesis. Budapest University of Technology and Economics, Budapest (2004).
- [134] S. Mishra, Vertex-coloring and strong edge-coloring. PhD. Thesis. IIT Madras, Chennai, India (2020).
- [135] J. Mycielski, Sur le coloriage des graphes. *Colloquium Mathematics* 3 (1955) 161–162.
- [136] S. Olariu, Paw-free graphs. *Information Processing Letters* 28 (1988) 53–54.
- [137] A. Prashant and S. Francis Raj, An optimal chromatic bound for the class of $\{P_3 \cup 2K_1, P_3 \cup 2K_1\}$ -free graphs. *ArXiv:2311.05231 [math.CO]* (2023).
- [138] A. Prashant, S. Francis Raj and M. Gokulnath, Bounds for the chromatic number of some pK_2 -free graphs. *Discrete Applied Mathematics* 336 (2023) 99–108.
- [139] A. Prashant, P. Francis and S. Francis Raj, Chromatic bounds for some subclasses of $(P_3 \cup P_2)$ -free graphs. In: *CALDAM 2022, Lecture Notes in Computer Science*, Springer 13179 (2022) 15–21.

- [140] L. Rabern, A note on Reed's conjecture. *SIAM Journal on Discrete Mathematics* 22 (2008) 820–827.
- [141] J. L. Ramirez-Alfonsin and B. Reed (Eds.), *Perfect Graphs*. Springer-Verlag, Berlin, 2001.
- [142] B. Randerath, The Vizing bound for the chromatic number based on forbidden pairs. PhD. Thesis. RWTH Aachen, Shaker Verlag (1998).
- [143] B. Randerath and I. Schiermeyer, 3-colorability $\in \mathcal{P}$ for P_6 -free graphs. *Discrete Applied Mathematics* 136 (2004) 299–313.
- [144] B. Randerath and I. Schiermeyer, Vertex colouring and forbidden subgraphs-A survey. *Graphs and Combinatorics* 20 (2004) 1–40.
- [145] B. Randerath, I. Schiermeyer and M. Tewes, Three-colorability and forbidden subgraphs. II: polynomial algorithms. *Discrete Mathematics* 251 (2002) 137–153.
- [146] M. Rao, Decomposition of (gem, co-gem)-free graphs. Unpublished manuscript, LIRMM, Montpellier, France (2007).
- [147] B. Reed, ω , Δ and χ . *Journal of Graph Theory* 27 (1998) 177–212.
- [148] N. Robertson, D. Sanders, P. Seymour and R. Thomas, The four-color theorem. *Journal of Combinatorial Theory, Series B* 70 (1997) 2–44.
- [149] N. Robertson, P. Seymour and R. Thomas, Hadwiger's conjecture for K_6 -free graphs. *Combinatorica* 13 (1993) 279–361.
- [150] N. Sauer, Vertex partition problems, in *Combinatorics, Paul Erdős is Eighty*, Bolyai Society Mathematical Studies, Eds. D. Miklós, V.T. Sós and T. Szönyi (1993) 361–377.
- [151] I. Schiermeyer, Chromatic number of P_5 -free graphs: Reed's conjecture. *Discrete Mathematics* 339 (2016) 1940–1943.
- [152] I. Schiermeyer, On the chromatic number of $(P_5, \text{windmill})$ -free graphs. *Opuscula Mathematica* 37 (2017) 609–615.
- [153] I. Schiermeyer and B. Randerath, Polynomial χ -binding functions and forbidden induced subgraphs: A survey. *Graphs and Combinatorics* 35 (2019) 1–31.
- [154] A. Scott, Induced trees in graphs of large chromatic number. *Journal of Graph Theory* 24 (1997) 297–311.
- [155] A. Scott and P. Seymour, A survey of χ -boundedness. *Journal of Graph Theory* 95 (2020) 473–504.
- [156] A. Scott, P. Seymour and S. Spirkl, Polynomial bounds for chromatic number. IV: A near-polynomial bound for excluding the five-vertex path. *Combinatorica* 43 (2023) 845–852.

- [157] A. Scott, P. Seymour and S. Spirkl, Polynomial bounds for chromatic number. III. Excluding a double star. *Journal of Graph Theory* 101 (2022) 323–340.
- [158] A. Scott and P. Seymour, Induced subgraphs of graphs with large chromatic number. XIII. New brooms. *European Journal of Combinatorics* 84 (2020) Article No.: 103024.
- [159] D. Seinsche, On a property of the class of n -colorable graphs. *Journal of Combinatorial Theory, Series B* 16 (1974) 191–193.
- [160] P. Seymour, Hadwiger’s conjecture. In: J. Nash Jr and M. Rassias (Eds.). *Open Problems in Mathematics*, Springer, Cham (2016) 417–437.
- [161] C. E. Shannon, The zero error capacity of a noisy channel. *Institute of Radio Engineers Transaction on Information Theory, IT-2* (1956) 8–19.
- [162] V. Sivaraman, Some problems on induced subgraphs. *Discrete Applied Mathematics* 236 (2018) 422–427.
- [163] D. P. Sumner, Subtrees of a graph and chromatic number. In: *The Theory and Applications of Graphs* (Kalamazoo, MI, 1980), G. Chartrand, Y. Alavi, D. L. Goldsmith, L. Lesniak-Foster and D. L. Lick (Eds.), Wiley, New York (1981) 557–576.
- [164] N. Trotignon and L. A. Pham, χ -bounds, operations, and chords. *Journal of Graph Theory* 88 (2018) 312–336.
- [165] N. Trotignon and K. Vušković, A structure theorem for graphs with no cycle with a unique chord and its consequences. *Journal of Graph Theory* 63 (2010) 31–67.
- [166] V. G. Vizing, On an estimate of the chromatic class of a p -graph. *Diskretnyi Analiz* 3 (1937) 25–30.
- [167] K. Wagner, Über eine Eigenschaft der ebenen Komplexe. *Mathematische Annalen* 114 (1937) 570–590.
- [168] S. Wagon, A bound on the chromatic number of graphs without certain induced subgraphs. *Journal of Combinatorial Theory, Series B* 29 (1980) 345–346.
- [169] D. B. West. *Introduction to Graph Theory* (2nd Edition). Prentice-Hall, Englewood Cliffs, New Jersey, 2000.
- [170] G. J. Woeginger and J. Sgall, The complexity of coloring graphs without long induced paths. *Acta Cybernetica* 15 (2001) 107–117.
- [171] D. Wu and B. Xu, Coloring of some crown-free graphs. *Graphs and Combinatorics* 39 (2023) Article No.: 106.
- [172] Y. Xu, The chromatic number of $(P_5, K_5 - e)$ -free graphs. Manuscript (2022). (Available earlier on: [ArXiv:2210.04682v1\[math.CO\]](https://arxiv.org/abs/2210.04682v1)(2022).)

-
- [173] Y. Xu, Coloring graphs without induced P_5 or $K_5 - e$. Applied Mathematics and Computation 461 (2024) Article No.: 128314.